

Dental / Oral

Spezialkatalog
Special catalog
Catálogo especial
Catalogue spécial
Catalogo speciale

Dental / Oral



Surgical Innovation is our passion



Chirurgische Innovation

ist unsere Leidenschaft

Wie kommt man dazu, über 14.000 chirurgische Instrumente zu entwickeln, zu fertigen und zu vermarkten? Produkte, die sich durch klare Alleinstellungsmerkmale auszeichnen. Es ist die Leidenschaft, neue Wege zu finden, die Menschen helfen und der Gesundheit dienen.

GB Surgical Innovation is our passion

What is the secret behind the development, manufacture and distribution of over 14,000 exclusive surgical instruments, products whose distinguishing characteristics truly set them apart from all the others? The answer is passion, the overwhelming desire to discover new ways of serving humankind in its search for ultimate health.

ES La innovación quirúrgica es nuestra pasión

¿Cómo es posible concebir, producir y comercializar más de 14.000 instrumentos quirúrgicos? Estamos hablando de productos que se caracterizan por unas propiedades exclusivas, claramente definidas. La clave está en que nos motiva la pasión por encontrar nuevos caminos para ayudar a las personas y fomentar la salud.

F Notre passion est l'innovation chirurgicale

Comment est-il possible de développer, fabriquer et commercialiser plus de 14 000 instruments chirurgicaux ? Des produits dont les caractéristiques distinctives sont leur position unique sur le marché. Et bien, ceci est en fait dû à la passion de vouloir trouver de nouvelles méthodes afin de venir en aide aux personnes et de servir la santé.

I L'innovazione nella chirurgia è la nostra passione

Che cosa ci spinge a progettare, produrre e distribuire più di 14.000 strumenti chirurgici dalle caratteristiche uniche? Sono la nostra passione e il desiderio di aiutare il prossimo e cercare nuove vie per migliorare la salute.





Am Anfang stand die Vision, aus kleinen Firmen eine international agierende Unternehmensgruppe zu bilden. Das war 1923. Heute beschäftigt die KLS Martin Group über 700 Mitarbeiter und ist einer der weltweit führenden Konzerne für Entwicklung, Produktion und Vertrieb medizintechnischer Produkte, die in enger Zusammenarbeit mit denjenigen entwickelt werden, die sie letztlich einsetzen: den Chirurgen.

GB

In the beginning there was a vision

Our vision, in 1923, was to create an internationally operating group of companies from a handful of smaller businesses. Today, the KLS Martin Group has a staff of over 700 and is one of the leading globally acting enterprises for the development, manufacture and distribution of medical devices. We work hand in hand with those holding the scalpel: the surgeon.

ES

Todo comienzo parte de una visión

Al principio la visión consistía en conformar, a partir de pequeñas empresas, un grupo empresarial con intervención a escala mundial. Corría el año 1923 en aquel entonces. Hoy en día, el KLS Martin Group da trabajo a más de 700 personas y se encuentra a nivel mundial entre los consorcios líderes dedicados al desarrollo, producción y comercialización de productos medicotécnicos, diseñados en estrecha colaboración con aquel grupo de personas que finalmente los emplean: los cirujanos.

F

Tout commença par une vision

Au début, en l'an 1923, naquit la vision de pouvoir former un groupe d'entreprises à activités internationales à partir de petites entreprises. Le groupe KLS Martin Group occupe actuellement plus de 700 employés et il est l'un des groupes leaders sur le marché mondial dans le secteur du développement, de la production et de la commercialisation de produits médico-techniques, ces produits ayant été développés en étroite collaboration avec ceux les utilisant, c'est-à-dire les chirurgiens.

I

All'inizio c'era una visione

All'inizio c'era una visione: fondere piccole ditte per creare un gruppo aziendale operante a livello internazionale. Era il 1923. Oggi il KLS Martin Group ha più di 700 dipendenti ed è una delle imprese leader al mondo nella progettazione, produzione e distribuzione di prodotti medicali creati in stretta collaborazione con gli utenti finali: i chirurghi.

Am Anfang
stand eine Vision



Gebrüder Martin, Tuttlingen
Karl Leibinger Medizintechnik, Mühlheim
KLS Martin, Umkirch
Stuckenbrock Medizintechnik, Tuttlingen
Rudolf Buck, Mühlheim



Standorte und Logistik – *unser Netzwerk für Sie*



Wo immer Sie sind, wir sind ganz in Ihrer Nähe. Mit eigenen, internationalen Vertriebsgesellschaften in den USA, Japan, Frankreich, Italien, Spanien, Russland und den Niederlanden sowie Handelsvertretungen in über 140 Ländern weltweit. Beliefert werden sie über das topmoderne Logistikzentrum in Tuttlingen. Wir sorgen dafür, dass alles, was Sie brauchen, gut ankommt: Just in time.

GB

Our network of locations and logistics

Wherever you may be, we're certainly not far away: We operate our own international distribution companies in the U.S.A., Japan, France, Italy, Spain, Russia and the Netherlands, as well as agencies in more than 140 countries. These are supplied in turn by our highly modern logistics centre in Tuttlingen. We make sure our partners get exactly the products they asked for: Just in time.

ES

Nuestra red de emplazamientos y transportes

Esté dónde esté, siempre estaremos cerca de Ud. Disponemos de sociedades de ventas propias e internacionales ubicadas en los EE.UU., Japón, Francia, Italia, España, Rusia y los Países Bajos, así como también, a escala mundial, de representaciones comerciales en más de 140 países. El centro logístico altamente moderno, situado en la localidad alemana de Tuttlingen, se encarga del suministro de su mercancía. Garantizamos que todos sus encargos lleguen en óptimas condiciones y justo a tiempo.

F

Notre réseau d'emplacements et de logistique

Peu importe où vous êtes, nous ne sommes jamais bien loin. Avec nos propres sociétés de distribution internationales aux Etats-Unis, Japon, France, Italie, Espagne, Russie et aux Pays-Bas ainsi que des représentations commerciales, nous sommes présents dans plus de 140 pays dans le monde entier. Les marchandises sont livrées à nos succursales depuis le centre logistique ultramoderne implanté à Tuttlingen. Nous faisons tout pour que les produits requis arrivent en bon état et au bon moment.

I

La nostra rete logistica e di sedi

Ovunque voi siate, noi siamo nelle vostre vicinanze, con società internazionali di vendita site negli Stati Uniti, in Giappone, Francia, Italia, Spagna, Russia e nei Paesi Bassi, ma anche con più di 140 rappresentanze commerciali sparse in tutto il mondo. Tutte le forniture partono dal modernissimo centro logistico di Tuttlingen. Qui, le vostre richieste vengono evase con la massima precisione perché tutto ciò di cui avete bisogno arrivi puntualmente ed in ottimo stato.

State of the Art – *Made in Germany*

Tuttlingen ist weltweit das Zentrum für Medizintechnik. KLS Martin hat einen entscheidenden Beitrag dazu geleistet. Auch heute noch entwickelt und fertigt die Gruppe fast ausschließlich in Deutschland. In topmodernen Produktionsanlagen, für bestimmte Produktgruppen sogar unter Reinraumbedingungen – und immer unter der Leitung von hochqualifizierten Ingenieuren und Fachpersonal. Das Ergebnis: Made in Germany.

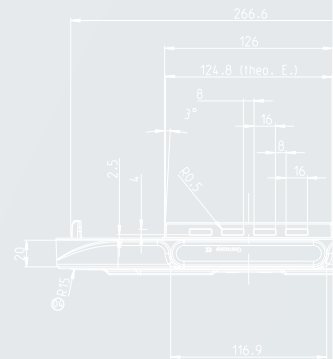
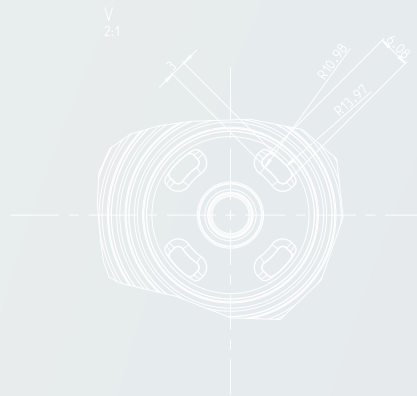
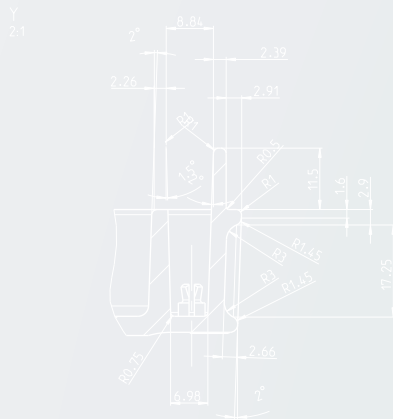

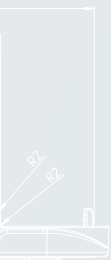

Gravur 0,2 mm erhaben
Erodienstruktur 18
nach VDI 3400 Ref.

GB

State of the art – Made in Germany

Tuttlingen is recognized as being the international handling centre for medical equipment, with KLS Martin having played a key role in this development. The focus of activity of the group is still largely Germany with regard to manufacturing and development. We are immensely proud of our ultramodern manufacturing plants, with clean room conditions for certain products, all of them professionally managed by highly qualified engineers and skilled technicians. The logical result: Made in Germany.

ES

La categoría del arte hecho en Alemania

Tuttlingen es el centro de la técnica médica a escala mundial. KLS Martin ha contribuido decisivamente a conseguir esta posición. Actualmente casi la totalidad de sus productos se desarrollan y manufacturan exclusivamente en Alemania. Disponemos de plantas de producción ultramodernas y determinados grupos de productos son elaborados incluso bajo condiciones de sala limpia – siempre bajo la dirección de ingenieros altamente cualificados y personal especializado. El resultado: Hecho en Alemania.

F

Etat de la technique Made in Germany

Dans le monde entier, Tuttlingen est le noyau de la technologie médicale. Et KLS Martin a énormément contribué à cette position. Aujourd'hui encore, le groupe développe et fabrique presque exclusivement en Allemagne, sur des installations de production ultramodernes, pour certains groupes de produits même en conditions de salle blanche, et toujours sous la direction d'ingénieurs hautement qualifiés et de personnel compétent. Le résultat : des produits « made in Germany ».

I

Avanguardia tecnologica Made in Germany

Tuttlingen è la capitale mondiale della tecnologia medica, un riconoscimento al quale KLS Martin ha contribuito in maniera sostanziale. Tuttora il gruppo concentra la progettazione e la produzione quasi esclusivamente in Germania, dove utilizza impianti di produzione all'avanguardia che per alcune categorie di prodotti prevedono persino condizioni da camera sterile. Ogni fase di produzione viene eseguita sotto il costante controllo di ingegneri e tecnici altamente qualificati. Il risultato: prodotti made in Germany.

14.000 Wege zu operieren – mit chirurgischen Instrumenten

Millionen Ärzte weltweit nutzen es und vertrauen darauf: das Qualitätsinstrumentarium von KLS Martin, das in Chirurgie und Dentalchirurgie Maßstäbe setzt. Die ursprünglich erste Produktgruppe ist auch heute noch eine der wichtigsten. Entwickelt und gefertigt werden die über 14.000 chirurgischen Instrumente nach strengsten Qualitätsvorgaben. Von der Auswahl der korrosionsbeständigen Chromstähle über Fertigung und Vergütung bis zum Finish und zur Endkontrolle.

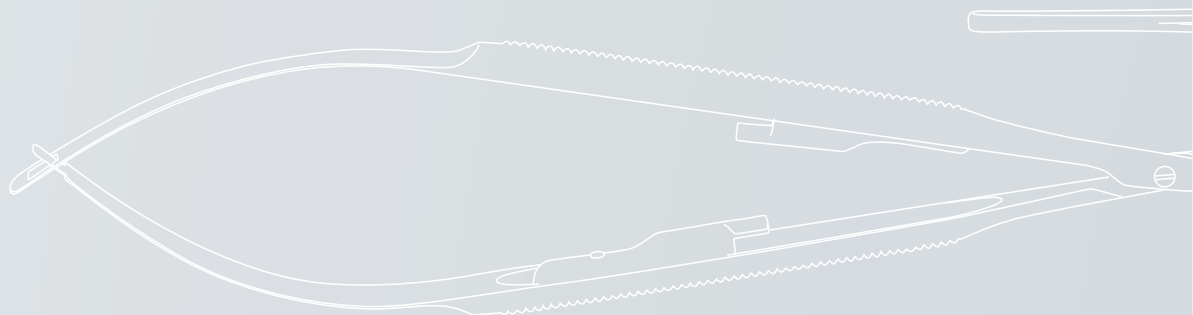

GB

14.000 ways to operate – with surgical instruments

Doctors worldwide use them and place their trust in them: quality instruments by KLS Martin, continually setting standards in the worlds of surgery and dental surgery. Our initial line of products is still one of the most important today. Our surgical instruments – over 14,000 in number – are developed and manufactured in compliance with the most stringent quality requirements, from the initial selection of corrosion-resistant chrome steel and the manufacturing and heat treatment right through to the final finish, inspection and testing.

ES

Los 14.000 modos de operar con instrumentos quirúrgicos

Millones de médicos en el mundo entero utilizan y depositan su confianza en el instrumental de calidad de KLS Martin, que sirve de norma en el mundo de la cirugía y de la cirugía dental. El primer grupo originario de productos sigue siendo hoy en día uno de los más importantes. El desarrollo y la manufactura de más de 14.000 instrumentos quirúrgicos se rigen según las especificaciones más exigentes de calidad. Es decir, incluye todos los pasos desde la selección de los aceros al cromo resistentes a la corrosión, pasando por la producción y el mejorado, hasta el acabado y el control final.

F

14 000 méthodes pour utiliser des instruments chirurgicaux

Plusieurs millions de médecins utilisent et font confiance dans le monde entier aux instruments chirurgicaux de qualité de KLS Martin, lesquels font référence dans les secteurs de la chirurgie et de la chirurgie dentaire. Le premier groupe de produits fabriqué à l'origine occupe encore aujourd'hui une place très importante. Les instruments chirurgicaux (actuellement plus de 14 000) sont développés et fabriqués selon de très sévères consignes en matière de qualité. Depuis la sélection des aciers chromés résistants à la corrosion, en passant par la fabrication et le traitement par trempé, jusqu'à la finition et au contrôle final.

I

14.000 modi di operare con strumenti chirurgici

Milioni di medici in tutto il mondo ripongono la loro fiducia nella qualità degli strumenti KLS Martin, una misura di riferimento nella chirurgia e nella chirurgia dentale. Il primissimo gruppo di strumenti prodotto dall'azienda è tuttora uno dei più importanti. Gli oltre 14.000 strumenti chirurgici vengono realizzati rispettando criteri rigidissimi in fase di progettazione e produzione, dalla scelta degli acciai cromatici resistenti alla corrosione, alla lavorazione, alla finitura ed al controllo finale.



Perfekter Service
für einen langen Werterhalt

Bewerten, richten, instandsetzen – Mario® RepServ ist der von KLS Martin weltweit angebotene Reparaturservice, der Ihre defekten Instrumente in kürzester Zeit wieder auf Vordermann bringt. Sie profitieren von langfristigem Werterhalt und kontrollierter Qualitätssicherung bei deutlich höheren Standzeiten Ihres Instrumentariums. Diesen Service bieten wir Ihnen unabhängig davon, ob die eingesandten Instrumente von KLS Martin sind oder nicht.



GB

Perfect service guarantees long-term maintenance of value

Evaluation, maintenance and repair – Mario® RepServ returns your malfunctioning instruments to perfect working order in the twinkling of an eye – thanks to KLS Martin and their worldwide repair service. You enjoy the benefits of long-term value retention, monitored quality assurance and the considerably increased operating lives of your instruments. You profit from this service whether or not you purchased your instrument from us – now that's customer service!

ES

Un servicio perfecto garantizado – Conservación del valor a largo plazo

Evaluar, ajustar, conservar – Mario® RepServ es el servicio de reparación ofrecido a escala mundial por KLS Martin que se encarga de poner en servicio su instrumental defectuoso en un mínimo de tiempo. Usted se beneficiará de una conservación del valor a largo plazo y de un aseguramiento controlado de la calidad, además del considerable aumento de la durabilidad de su instrumental. Este servicio se lo ofrecemos, independientemente de que los instrumentos enviados sean o no de KLS Martin.

F

Un service parfait garantissant une préservation des valeurs à long terme

Evaluer, ajuster, remettre en état – Mario® RepServ est le service de réparation offert dans le monde entier par KLS Martin et permettant de remettre en état vos instruments défectueux en très peu de temps. Vous profitez ainsi d'une préservation à long terme des valeurs et d'une assurance qualité contrôlée tout en bénéficiant de durées de vie plus élevées pour vos instruments chirurgicaux. Nous vous proposons ce service, même si les instruments nous étant envoyés ne sont pas de KLS Martin.

I

Servizio perfetto per un valore che dura nel tempo

Analizzare, regolare, riparare – Mario® RepServ è il sistema offerto da KLS Martin in tutto il mondo per riparare in brevissimo tempo gli strumenti difettosi. In questo modo possiamo garantirvi un valore che dura nel tempo, controlli di qualità eccellenti e intervalli di manutenzione particolarmente lunghi. KLS Martin offre questo servizio anche per gli strumenti di altri fornitori.





Frischlin Germany
CE
30-561-22

Qualitätssicherung ohne Kompromisse

Unsere Produkte erfüllen den Anspruch anwendungsbezogener Funktionalität, intelligenter Handhabung und hoher Qualität. Und wenn es um die Erfüllung dieses Anspruchs geht, machen wir keine Kompromisse. Um dies zu gewährleisten, unterhält KLS Martin ein eigenes hochmodernes Labor sowie ein Technikum, in denen die Qualität unserer Erzeugnisse – auch unter extremen Bedingungen – auf „Herz und Nieren“ getestet und dokumentiert werden.

GB

Quality assurance uncompromising

Our products are designed to consistently meet high demands for application-oriented functionality, intelligent operation and top quality. And we are not prepared to compromise when it comes to meeting the justified expectations of our customers, present and future – your standards become ours. KLS Martin runs their own ultramodern laboratories and a pilot plant, where our products are stress-tested under extreme conditions – every step is documented before release.

ES

Un seguro de calidad sin compromisos

Nuestros productos cumplen el requisito de estar dotados de la funcionalidad conforme a su aplicación, su manipulación es inteligente y son de alta calidad. No transigimos a la hora de cumplir con estas condiciones esenciales. Por este motivo, KLS Martin mantiene un laboratorio propio, altamente moderno, así como una escuela técnica, donde se ensaya y documenta la calidad de nuestros productos – inclusive bajo condiciones extremas –, examinándolos “hasta la médula”.

F

Une assurance qualité sans compromis

Nos produits répondent aux exigences requises par une fonctionnalité relative à l'application, un maniement intelligent et une qualité élevée. Et nous n'acceptons aucun compromis lorsqu'il s'agit de répondre à ces exigences. KLS Martin possède à ce but son propre laboratoire ultramoderne et son centre technique dans lesquels la qualité de nos produits fabriqués est testée minutieusement – même sous des extrêmes conditions – et les résultats des tests sont documentés.

I

Assicurazione della qualità senza compromessi

I nostri prodotti sono stati progettati guardando alle esigenze della prassi applicativa, offrono una manipolazione intelligente e sono di qualità elevata. A tale riguardo non facciamo compromessi. Per garantire questo standard, KLS Martin ha un laboratorio altamente moderno e un centro tecnologico in cui controlla e documenta la qualità di tutti i prodotti, anche in condizioni estreme.

Zertifiziertes Qualitätsmanagement – nach internationalen Standards

Jedes unserer Produkte unterliegt vor Auslieferung einer umfassenden Endkontrolle. Unser Qualitätsmanagement ist nach den internationalen Normen DIN EN ISO 13485 und DIN EN ISO 9001 zertifiziert. Es orientiert sich zusätzlich an den nordamerikanischen CMDCAS-Richtlinien. Als sichtbares Zeichen der Übereinstimmung unserer Erzeugnisse mit der europäischen Richtlinie 93/42/EWG versehen wir unsere Medizinprodukte mit dem CE-Zeichen.





GB

Compliance with international standards – certified quality management

Each and every one of our instruments is subjected to comprehensive final inspection prior to shipping. Our quality management is certified according to international standards DIN EN ISO 13485 and DIN EN ISO 9001. It has also committed itself to compliance with the North American Directive CMDCAS. In order to provide our customers with an unequivocal and visible statement regarding our compliance with European Directive 93/42/EEC, each of our medical products is labelled with the CE mark.

ES

El cumplimiento de los estándares internacionales – Gestión certificada de calidad

Antes de la entrega sometemos a cada uno de nuestros productos a un control exhaustivo final. Nuestro sistema de gestión de calidad se ha certificado de acuerdo con las normas internacionales DIN EN ISO 13485 y DIN EN ISO 9001. Además, se orienta por la normativa norteamericana CMDCAS. Nuestros productos médicos están provistos del símbolo CE, como prueba visible de la conformidad de nuestros productos con la directiva europea 93/42/CEE.

F

Adaptation aux normes internationales – gestion de qualité certifiée

Chacun de nos produits est soumis, avant la livraison, à un vaste contrôle final. Notre gestion de la qualité est certifiée conforme aux normes internationales DIN EN ISO 13485 et DIN EN ISO 9001. Elle s'oriente de plus aux directives CMDCAS en vigueur en Amérique du nord. Nos produits médicaux sont pourvus du symbole CE à titre de signe distinctif pour leur conformité avec la directive européenne 93/42/CEE.

I

Rispetto degli standard internazionali – gestione certificata della qualità

Prima di lasciare lo stabilimento, ognuno dei nostri prodotti viene sottoposto ad un controllo finale scrupoloso. Il nostro sistema di gestione della qualità è certificato secondo le norme internazionali DIN EN ISO 13485 e DIN EN ISO 9001 e si orienta, inoltre, alle direttive nordamericane CMDCAS. Per evidenziare la conformità dei nostri prodotti alla direttiva europea 93/42/CEE, i nostri strumenti medici sono muniti del marchio CE.

Wir setzen Standards

für die Instrumentenaufbereitung

Wie lassen sich Medizinprodukte vor mechanischer, thermischer oder chemischer Belastung schützen? Was muss man bei der Aufbereitung und Pflege besonders feingliedriger Mikrochirurgieinstrumente berücksichtigen? Als Mitglied wichtiger Gremien und Arbeitskreise – wie z. B. dem Arbeitskreis Instrumenten-Aufbereitung AKI – gibt KLS Martin Antworten und erarbeitet Lösungen für die optimale Aufbereitung und Pflege von Instrumenten. Von der Auswahl angemessener Reinigungsverfahren bis hin zu Sterilisationsverfahren.

GB

Standards and best practice: instrument preparation

How best to protect surgical instruments from mechanical, thermal and chemical stresses? What steps are performed to ensure optimal preparation and care of highly delicate microsurgical instruments? KLS Martin, in their capacity as member of important advisory boards and working groups – for example, Working Group Instrument Preparation AKI – is in a position to provide answers and solutions to all inquiries with regard to the optimal preparation and care of instruments, ranging from knowledgeable advice on appropriate cleaning methods through sterilization processes.

ES

Los estándares y la mejor práctica para la preparación de instrumentos

¿Cómo se pueden proteger los productos médicos contra la actuación de factores mecánicos, térmicos y químicos? ¿Qué es lo que hay que considerar en el momento de preparación y cuidado del instrumental microquirúrgico, constituido fundamentalmente por componentes finos? En función de miembro de asociaciones y comités laborales importantes – como por ejemplo, el Comité Alemán de Trabajo de Preparación de Instrumental AKI – KLS Martin ofrece respuestas y elabora soluciones para el tratamiento y cuidado óptimos del instrumental. Éstas abarcan desde la selección de métodos de limpieza adecuados hasta el procedimiento de esterilización.

F

Normes et pratiques idéales pour la préparation des instruments

Comment protéger les produits médicaux contre d'éventuelles contraintes mécaniques, thermiques ou chimiques? Quels points doivent être pris en considération pour le traitement et l'entretien d'instruments micro-chirurgicaux à fine ossature? A titre de membre d'importants organismes et cercles de travail, tels que par exemple l'AKI (Arbeitskreis Instrumenten-Aufbereitung = cercle de travail pour le traitement des instruments), KLS Martin donne des réponses et élabore des solutions pour assurer un traitement et un entretien optimaux des instruments. Depuis la sélection de procédés de nettoyage adéquats jusqu'au procédé de stérilisation.

I

Standard e "best practice" per la preparazione degli strumenti

Come si possono proteggere gli strumenti medici da agenti aggressivi di tipo meccanico, termico o chimico? Cosa occorre tenere presente nella preparazione e nella manutenzione di strumenti microchirurgici particolarmente delicati? Quale membro di importanti organi e gruppi di lavoro, come ad esempio AKI, il gruppo tedesco di lavoro per la corretta preparazione degli strumenti, KLS Martin dà risposta e sviluppa soluzioni per la preparazione e la manutenzione ottimali degli strumenti, dalla scelta dei sistemi di pulizia più idonei alle procedure di sterilizzazione.







Lebenslange Garantie
für MARTIN-Instrumente



Lebenslange Garantie – wann immer Sie sie brauchen

Keine Frage, wir sind stets auf der Suche nach der noch besseren Lösung. Das zeichnet den kontinuierlichen Fortschritt in unserem Produktportfolio aus. Gleichwohl sind alle unsere Instrumente qualitativ erstklassig und werden höchsten Ansprüchen gerecht. Und weil wir davon überzeugt sind, gewähren wir auf jedes Instrument bei sach- und fachgerechtem Einsatz eine lebenslange Garantie.

GB

Whenever you need it –
our lifetime guarantee

Our determined and ongoing search for the perfect solution is reflected in the dynamic nature of our product portfolio. You simply will not find better instruments on the market. And because we truly believe in the outstanding quality of our products, we offer a lifelong guarantee on each instrument, in connection with appropriate and professional use.

ES

Necesite lo que necesite –
la garantía es de por vida

Lo cierto es que siempre estamos en la búsqueda de una solución que sea aún mejor. Esto es lo que determina el progreso continuado de nuestra cartera de producción. Todos nuestros instrumentos son de la misma calidad máxima cumpliendo, por lo tanto cumplen con los requisitos más exigentes. Y como estamos convencidos de ello, garantizamos en todo nuestro instrumental una garantía de por vida, siempre y cuando se utilice como es debido y según las normativas.

F

Si jamais vous en
avez besoin – notre
garantie à vie

Nous sommes, sans aucun doute, toujours à la recherche de la solution optimale. Ce fait caractérise le progrès continu dans notre porte-feuille de produits. Tous nos instruments sont à la fois de toute première qualité et conformes à des exigences maximales. Et étant donné ce fait, nous garantissons sur chaque instrument une garantie à vie, à condition que les instruments soient utilisés de manière adéquate et compétente.

I

Ogni qual volta ne avete
bisogno – la nostra garanzia
a vita

Essendo alla ricerca di soluzioni sempre migliori, i nostri prodotti vengono costantemente migliorati. Essi sono di qualità eccellente e soddisfano persino le esigenze più elevate. Per questo possiamo accordare una garanzia a vita per ogni strumento impiegato in modo appropriato e corretto.

Instrumente schneller finden – die Katalog-Handhabung

Es ist ganz einfach: Die Artikelnummer gibt Auskunft über Produkt, Produktgruppe und Größe/Figur des Instruments. Jedes Produkt wird in Größe und Funktion vollständig beschrieben sowie maßstabsgetreu abgebildet – die Arbeitsenden je im Verhältnis 1 : 1. So finden Sie schneller, was Sie wirklich brauchen.



GB

Finding the instruments you need – how to use the catalogue

Straightforward and easy: The article number informs you about the product, product group and instrument size. Size and function of each product are described in full detail and illustrated to scale – the working ends in a ratio of 1 : 1. You can quickly find exactly what you are looking for.

ES

Encuentre el instrumental que necesita – Modo de consultar el catálogo

Es muy simple: El número de artículo facilita una información acerca del producto, el grupo de producto y el tamaño del instrumental. Encontrará la descripción completa de tamaño y función de cada producto y una ilustración a escala; los extremos funcionales aparecerán en relación 1 : 1. Así Ud. podrá encontrar más rápidamente lo que realmente necesita.

F

Comment trouver les instruments requis – l'utilisation du catalogue

C'est tout simple : le numéro d'article fournit des informations sur le produit, le groupe de produits et la taille de l'instrument. Une description détaillée de la taille et du fonctionnement de chaque produit est fournie et tous les produits sont illustrés à l'échelle – les extrémités des instruments étant illustrées au rapport 1 : 1. Ainsi vous trouvez plus rapidement ce dont vous avez vraiment besoin.

I

Trovare gli strumenti che cercate – I cataloghi

È semplicissimo: il codice articolo fornisce informazioni sul prodotto, sulla categoria e sulla grandezza dello strumento. Il catalogo presenta una descrizione dettagliata di ciascun prodotto, delle sue dimensioni e funzioni nonché un'illustrazione in scala degli strumenti, le cui estremità sono riprodotte in rapporto 1 : 1. In questo modo trovate più velocemente ciò di cui avete veramente bisogno.

Abbildungsmaßstab
Illustration scale
Los productos en escala
Produits à l'échelle
Prodotti dimensioni



Autor (wenn vorhanden)
Author (if available)
Autor (si lo hay)
Auteur (s'il existe)
Autore (se disponibile)

Angaben zum Produkt
Product information
Datos sobre el producto
Données sur le produit
Indicazioni relative al prodotto

Salyer
11-339-12 – 11-339-18
für Lippen-, Kiefer-, Gaumenspalte
for Cleft Palate
para fisura paladar
pour fente du palais
per cheilo-labbro-palato schisi

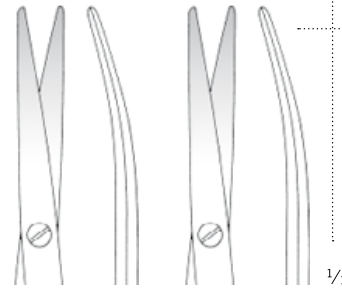

Arbeitsenden
Working end
El extremo funcional
del producto
Extrémité opératoire
du produit
L'estremità funzionale
del prodotto

11-339-12
12,5 cm / 5"
feines Modell
fine pattern
modelo fino
modèle fin
modello delicato

11-339-18
18 cm / 7"
feines Modell
fine pattern
modelo fino
modèle fin
modello delicato

Maße
Dimensions
Dimensiones
Dimensions
Dimensioni

Angaben zum Produkt
Product information
Datos sobre el producto
Données sur le produit
Indicazioni relative al prodotto

Artikelnummer
Item/order number
Nº del artículo
Numéro d'article
Codice articolo

Nummernschlüssel
Number code
Clave del número
Code des numéros
Chiave del codice

11-339-12

1 2 3

1 Artikelgruppe oder Disziplin
Product group or discipline
Grupo de artículos o especialidad
Groupe d'articles ou discipline
Gruppo di articoli o disciplina

2 Laufende Nummer innerhalb der Gruppe oder Disziplin
Consecutive number within the group or discipline
Número corrido dentro del grupo o especialidad
Número courant au sein du groupe ou de la discipline
Numero progressivo all'interno del gruppo o della disciplina

3 Größe/Figur des Instruments
Size/shape of instrument
Tamaño/forma del instrumento
Taille/forme de l'instrument
Dimensione/forma dello strumento

Übersichtstafel

Table of Contents

Tabla de catálogo

Contenu

Indice di catalogo



Übersichtstafel

Table of Contents

Tabla de catálogo

Contenu

Indice di catalogo

10

1-6



Skalpelle
Scalpels
Bisturíes
Bistouris
Bisturi

17

65-70

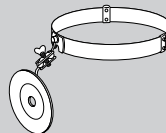

Diagnostik
Diagnostics
Diagnóstico
Diagnostic
Diagnostica

11

7-30



Scheren
Scissors
Tijeras
Ciseaux
Forbici

71-91



OP-Leuchten, Untersuchungsleuchten
Operating theatre lights, examination lights
Lámparas de quirófano, lámparas de
examinación
Lampes opératoires, lampes d'examen
Lampade scialitiche, Lampade diagnostiche

12

31-42



Pinzetten
Forceps
Pinzas
Pincers
Pinze

18

93-96

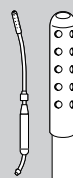

Chirurgische Sauger
Suction cannulas
Tubos de aspiración
Cannulas d'aspiration
Tubi d'aspirazione

13

43-49



Arterienklemmen
Artery Forceps
Pinzas hemostáticas
Pincers hémostatiques
Pinze emostatiche

20

97-108

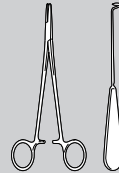

Nadelhalter
Needle holders
Porta agujas
Porte aiguilles
Portaghi

15

51-61

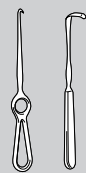

Wundhaken und Abhalter
Hooklets and retractors
Ganchitos y separadores
Crochets et ecarteurs
Divaricatori

23

109-134

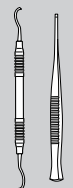

Meißel, Raspatorien
Chisels, periosteal elevators
Cinceles, periostótomos
Ciseaux burins, raspatoires
Scalpelli, periostotomi

16

63-64

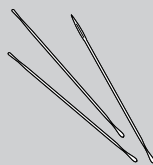







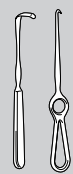

Knopfsonden, Watteträger
Probes, applicators
Sondas, porta algodones
Sondes, porte cotons
Sonde, porta cotoni

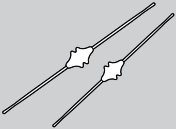
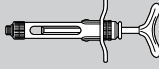
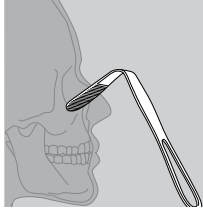
24

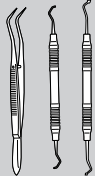
135-138

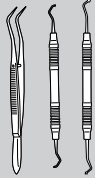

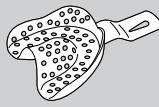
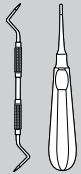
Hauthäkchen
Skin hooklets
Ganchitos para piel
Erignes cutanées
Uncini cutanei

35 139-140		Knopfsonden Probes Sondas abotonadas Sondes boutonnées Sonde a bottone	42 279-284		Spritzen Cartridge syringes Jeringas para cartucho apollas Seringues à ampoule Siringhe ampollari
38 141-174		Knocheninstrumente Bone instruments Instrumentos para hueso Instruments à l'os Strumenti per osso	42 285-290		Mundspiegel Mouth mirrors Espejos de boca Miroirs à bouche Specchietti
175-224		Mund-, Kiefer- und Gesichtschirurgie Oral and Craniomaxillofacial surgery Cirugía oral y maxilofacial Chirurgie orale et maxillofaciale Chirurgia orale e maxillofaciale	43 291-347		Parodontologie Periodontologie Parodontologia Parodontologie Parodontologia
39 225-226		Tamponadenstopfer Gauze packers Taponeadores Porte-tampons Tamponatori	44 349-371		Füllungsinstrumente Filling instruments Instrumentos para obturaciones Instruments pour plombages Otturatori
40-41 227-263		Zahnzangen Extracting forceps Forceps dentales Daviers Pinze per estrazione	46 373-392		Abdrucklöffel Impression trays Cubetas para impresiones Porte empreintes Portaimpronte
42 265-278		Wurzelheber Root elevators Elevadores para raíces Elévateurs de racines Leve per radici	47 393-406		Technikzangen Technic pliers Alicates para técnica Pincers prothétiques Tenaglie per tecnica

Übersichtstafel

Table of Contents
Tabla de catálogo
Contenu
Indice di catalogo

54

407-409

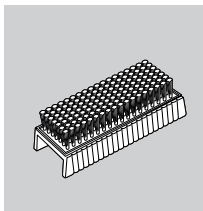

Asepsis
Asepsis
Asepsia
Asepsie
Asepsi

55

411-423

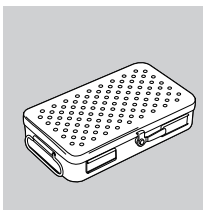

Hygiene, Aufbewahrung
Hygiene, storage
Higiene, almacenaje
Hygiène, stockage
Igiene, magazzinaggio

56

425-432

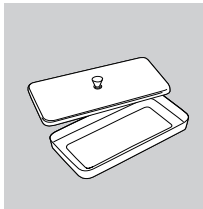

Gefäße aus Edelstahl
Stainless steel receptacles
Recipientes de acero inoxidable
Récipients en acier inoxydable
Recipienti di acciaio inossidabile

57-71

433-444

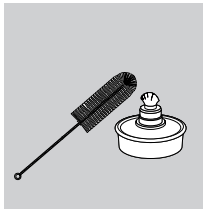

Verschiedenes
Miscellaneous
Diversos artículos
Articles divers
Articoli diversi

80

445-462

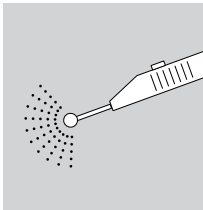

HF-Chirurgie
HF Surgery
Cirugía AF
Chirurgie HF
Chirurgia AF

463-492



Index
Index
Indice
Index
Indice

Weitere Kataloge von KLS Martin

Zu den folgenden Produktgruppen sind jeweils eigene Kataloge verfügbar, die Sie gerne bei uns anfordern können:

Further catalogs of KLS Martin

For the following product groups additional catalogs are available. Please ask for your personal copy:

Más catálogos de KLS Martin

Para los grupos siguientes tenemos catálogos individuales disponibles. No duden pedirnos más ejemplares:

Autres catalogues de KLS Martin

Pour les groupes de produits suivants sont disponibles des catalogues additionnels dont vous pouvez demander le nombre désiré:

Altri cataloghi di KLS Martin

Per i gruppi di prodotti seguenti sono disponibili cataloghi addizionali. La preghiamo di informarci se desidera altre copie:

Deckenversorgungseinheiten
Ceiling-mounting systems
Unidades de alimentación de techo
Unités d'alimentation montées au plafond
Sistemi pensili

OP-Leuchten
Operating Theatre Lights
Lámparas de quirófano
Lampes opératoires
Lampade scialitiche

HF-Chirurgie
HF Surgery
Cirugía AF
Chirurgie HF
Chirurgia AF

Mund-, Kiefer- und Gesichtschirurgie
Oral and Craniomaxillofacial surgery
Cirugía oral y maxilofacial
Chirurgie orale et maxillofaciale
Chirurgia orale e maxillofaciale

MicroStop[®]-Sterilcontainer
MicroStop[®] Sterile Containers
Contenedores estériles *MicroStop*[®]
Conteneurs stériles *MicroStop*[®]
Contentitori per la sterilizzazione *MicroStop*[®]

10

Skalpelle

Scalpels
Bisturíes
Bistouris
Bisturi

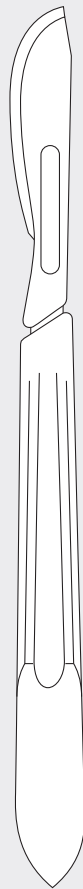

Zahnfleischmesser

Gum knives

Bisturíes para encías

Couteaux à gencives

Coltelli per gengive



1/2

Ash
10-050-01
No. 1
15,5 cm / 6 1/8"



1/2

Ash
10-050-02
No. 2
15,5 cm / 6 1/8"



1/2

Ash
10-050-03
No. 3
15,5 cm / 6 1/8"

Skalpellgriffe

Scalpel Handles
Mangos de bisturí
Manches pour bistouris
Manici per bisturi

Skalpelle

Scalpels
Bisturíes
Bistouris
Bisturi

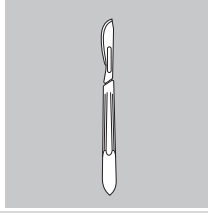

10



Fig. 10 - 17

1/2

10-116-03
16 cm / 6 2/8"
1,0/1,5 mm



Fig. 10 - 17

1/2

10-117-03
16 cm / 6 2/8"
1,5/2,0 mm

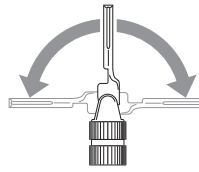

Fig. 10 - 17

1/2

10-118-03
15,5 cm / 6 1/8"
Schwenkkopf
swivel head
con cabeza orientable
à tête pivotante
con testa inclinabile



Fig. 10 - 17

1/2

10-120-04
16,5 cm / 6 2/8"



Safety edge
for glove
protection!



Fig. 10 - 17

1/2

10-130-03
No. 3
12 cm / 4 6/8"
massiv
solid
macizo
solide
pieno



Fig. 10 - 17

1/2

10-137-07
No. 7
16 cm / 6 2/8"
massiv
solid
macizo
solide
pieno



Fig. 10 - 17

1/2

10-137-71
No. 7K
12,5 cm / 4 7/8"
massiv, kurz
solid, short
macizo, corto
solide, court
pieno, corto



Fig. 10 - 17

1/2

10-146-03
No. 3
14 cm / 5 4/8"
massiv, rund
solid, round
macizo, redondo
solide, rond
pieno, rotondo



Fig. 10 - 17

1/2

10-147-03
No. 3
14 cm / 5 4/8"
massiv, rund, abgewinkelt
solid, round, angled
macizo, redondo, angulado
solide, rond, coudé
pieno, rotondo, angolare

Skalpellsklingen

Scalpel Blades

Hojas de bisturí

Lames de bistouris

Lame per bisturi



10-199-00

Skalpellsklingen-Entferner

Scalpel Blade Remover

Quita-hojas

Enlève-lame

Distributore lame

einzel verpackt, VE = 100 Stück
single packed, SU = 100/pack
envase individual, UV = 100 piezas
enveloppe individuelle,
UC = 100 untiés
bustina individuale, UV = 100 pezzi

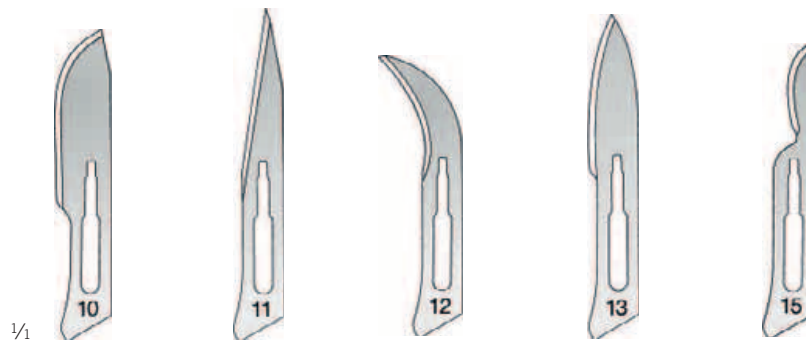

unsteril • non-sterile • no estéril • non-stérile • non sterile

10-150-10 10-150-11 10-150-12 10-150-13 10-150-15

Fig. 10 Fig. 11 Fig. 12 Fig. 13 Fig. 15

sterileR

steril • sterile • estéril • stérile • sterile

10-155-10 10-155-11 10-155-12 10-155-13 10-155-15

Fig. 10 Fig. 11 Fig. 12 Fig. 13 Fig. 15

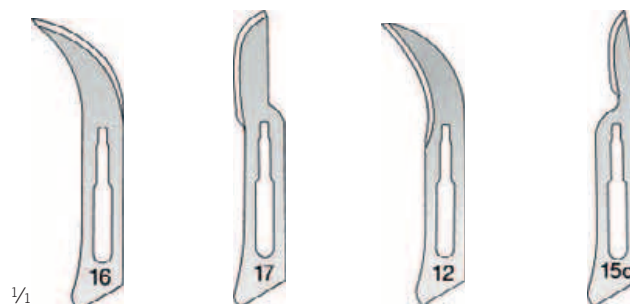

unsteril • non-sterile • no estéril • non-stérile • non sterile

10-150-16 10-150-17 10-151-12 10-151-15

Fig. 16 Fig. 17 Fig. 12 D Fig. 15 C

sterileR

steril • sterile • estéril • stérile • sterile

10-155-16 10-155-17 10-156-12 10-156-15

Fig. 16 Fig. 17 Fig. 12 D Fig. 15 C

Skalpellgriffe, Mikro-Skalpellklingen

Scalpel Handles, Micro Scalpel Blades
 Mangos de bisturí, Micro hojas de bisturí
 Manches pour bistouris, Micro lames de bistouris
 Manici per bisturi, Micro lame per bisturi

Skalpelle

Scalpels
 Bisturíes
 Bistouris
 Bisturi

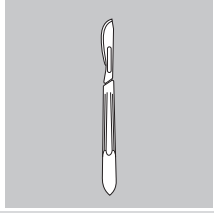

Ti



1/2

10-159-00
 13,5 cm / 5 3/8"

für Mikro-Skalpellklingen
 for micro scalpel blades
 para micro hojas
 pour micro-lames de bisturis
 per micro lame

einzel verpackt
 Packung mit 25 Stück
 single packed
 package with 25 units
 envase individual
 paquete con 25 unidades
 enveloppe individuelle
 boîte de 25 lames
 bustina individuale
 scatola di 25 lame



1/1

sterileR

steril • sterile • estéril • stérile • sterile

10-160-61	10-160-62	10-160-63	10-160-64	10-160-65
Fig. 61	Fig. 62	Fig. 63	Fig. 64	Fig. 65



1/2

10-160-01
 13,5 cm / 5 3/8"

für Mikro-Skalpellklingen
 for micro scalpel blades
 para micro hojas
 pour micro-lames de bisturis
 per micro lame



1/1

sterileR

steril • sterile • estéril • stérile • sterile

10-160-66	10-160-67	10-160-68	10-160-69
Fig. 66	Fig. 67	Fig. 68	Fig. 69

Einmalskalpelle

Disposable Scalpels
Bisturíes desechables
Bistouris à usage unique
Bisturi per uso unico

sterileR



steril • sterile • estéril • stérile • sterile						
10-295-10	10-295-11	10-295-12	10-295-13	10-295-15	10-296-12	10-296-15
Fig. 10	Fig. 11	Fig. 12	Fig. 13	Fig. 15	Fig. 12 D	Fig. 15 C

steril
einzeln verpackt
Packung mit 10 Stück

stérile
enveloppe individuelle
boîte de 10 bisturis

sterile
single packed
package with 10 units

sterile
bustina individuale
scatola di 10 bisturi

estéril
envase individual
paquete con 10 unidades

11

Scheren

Scissors

Tijeras

Ciseaux

Forbici

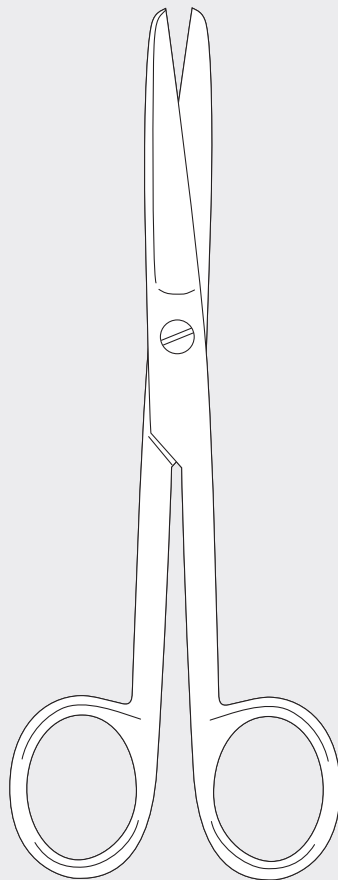

Chirurgische Scheren

Operating scissors

Tijeras quirúrgicas

Ciseaux chirurgicaux

Forbici per chirurgia

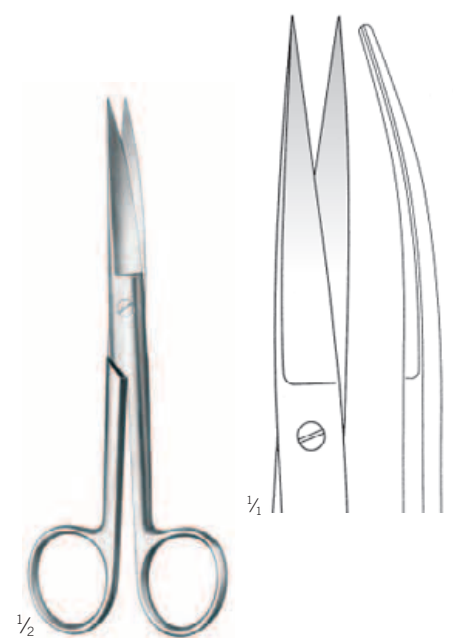
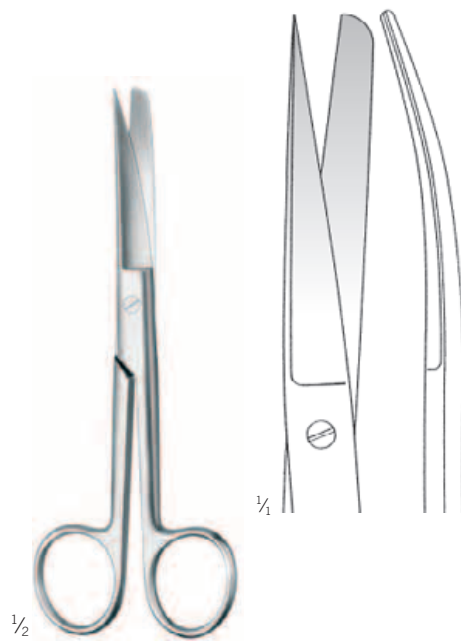
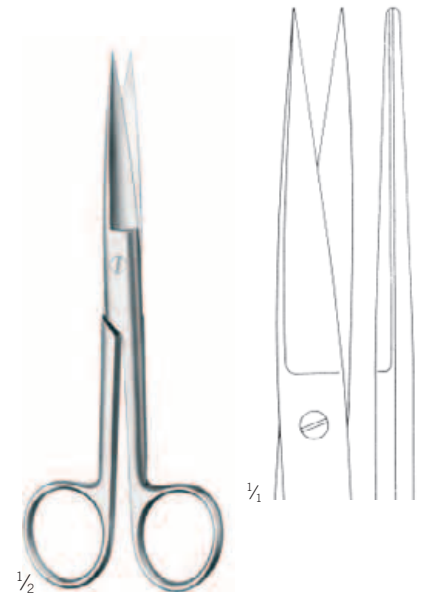
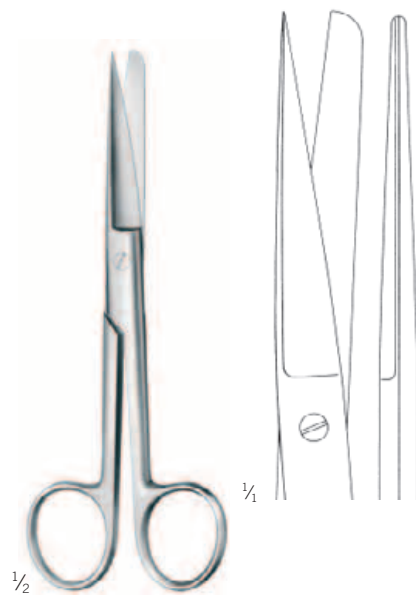
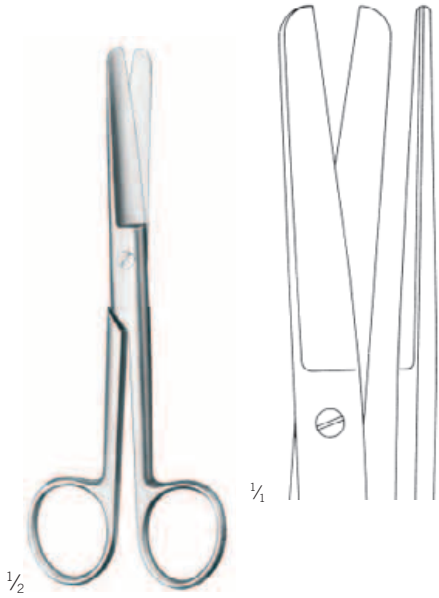

Chirurgische Scheren

Operating scissors
Tijeras quirúrgicas
Ciseaux chirurgicaux
Forbici per chirurgia

Scheren

Scissors
Tijeras
Ciseaux
Forbici

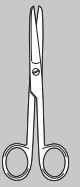

11

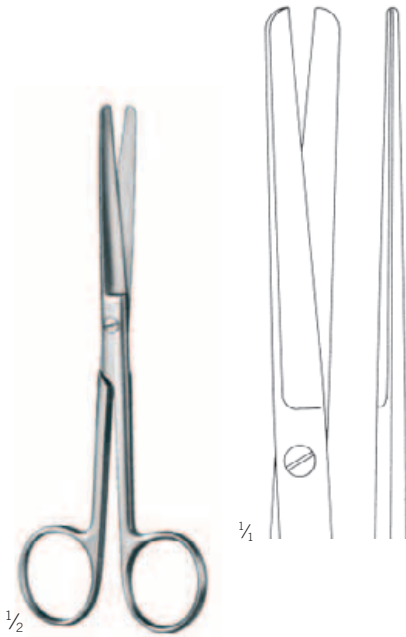

11-120-14
14,5 cm / 5 7/8"

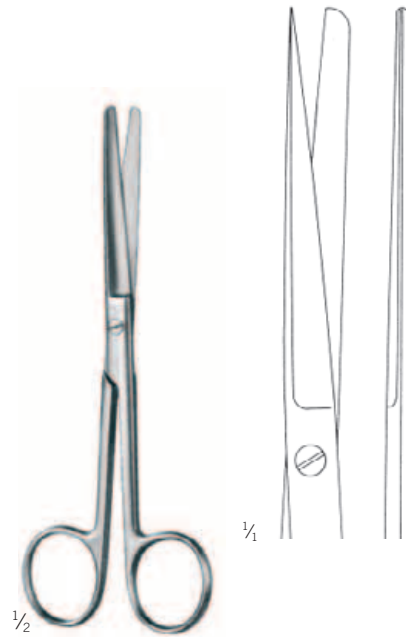

11-122-14
14,5 cm / 5 7/8"

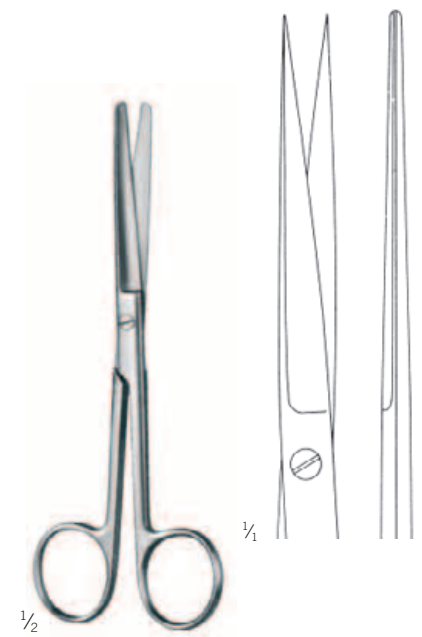

11-124-14
14,5 cm / 5 7/8"



11-125-14
14,5 cm / 5 7/8"

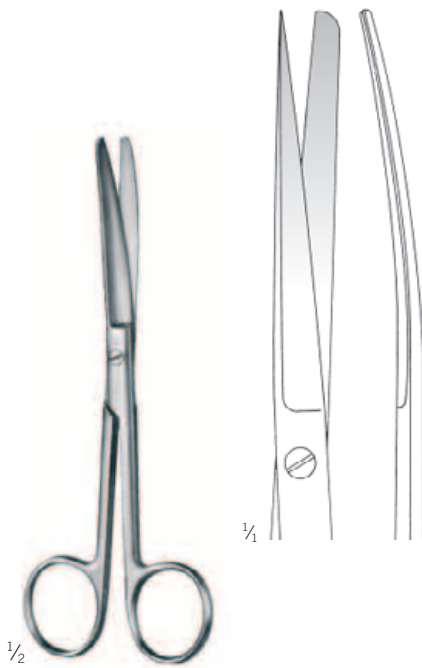

11-127-14
14,5 cm / 5 7/8"

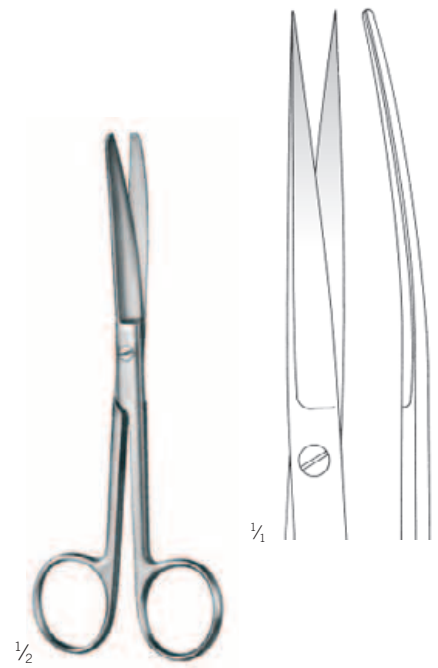

11-129-14
14,5 cm / 5 7/8"

Chirurgische Scheren, Präparierscheren

Operating scissors, dissecting scissors

Tijeras quirúrgicas, tijeras de disección

Ciseaux chirurgicaux, ciseaux à dissection

Forbici per chirurgia, forbici per dissezione

finoLine



1/2

Kelly
11-226-16 - 11-227-16
16 cm / 6 2/8"

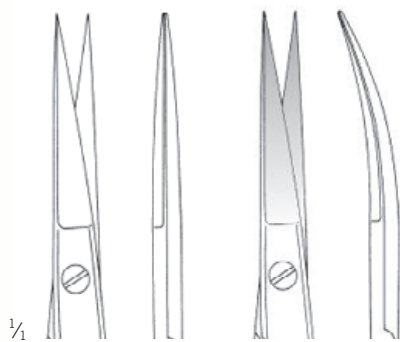

1/4

11-226-16

11-227-16

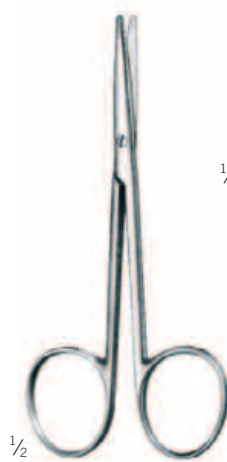

1/2

Metzenbaum
11-248-11 - 11-249-11
11,5 cm / 4 4/8"

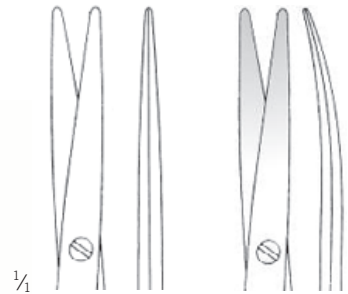

1/4

11-248-11

11-249-11



1/2

Metzenbaum
11-250-14 - 11-259-14
14,5 cm / 5 4/8"



1/4

11-250-14

11-252-14

11-254-14

11-255-14

11-257-14

11-259-14

Präparierscheren

Dissecting scissors
Tijeras de disección
Ciseaux à dissection
Forbici per dissezione

Scheren

Scissors
Tijeras
Ciseaux
Forbici

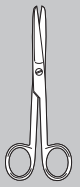

finoLine



11-264-15



11-265-15



11

Metzenbaum

15,5 cm / 6 1/8"



1/2

Metzenbaum-Nelson

11-280-18

18 cm / 7 1/8"

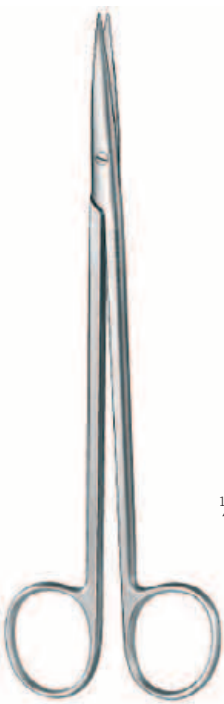

1/2

Metzenbaum-Nelson

11-284-18

18 cm / 7 1/8"

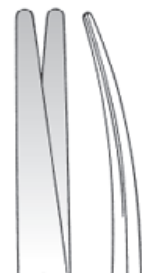

1/2

Metzenbaum-Nelson

11-285-18

18 cm / 7 1/8"

Präparierscheren

Dissecting scissors
Tijeras de disección
Ciseaux à dissection
Forbici per dissezione

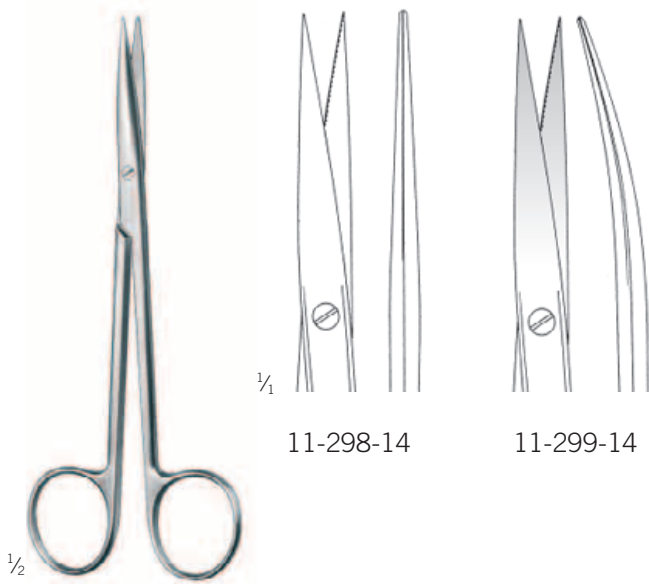

11-298-14

11-299-14

Metzenbaum

11-298-14 - 11-299-14

14,5 cm / 5 7/8"

gezahnt
toothed
dentadas
dentelés
dentate

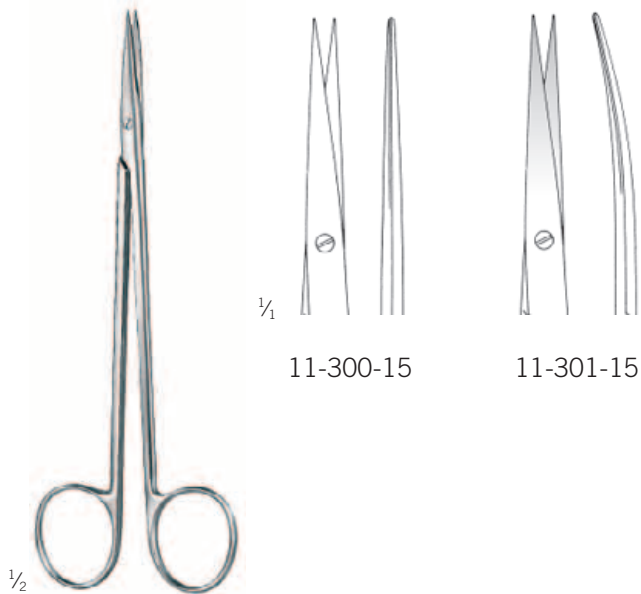

11-300-15

11-301-15

11-300-15 - 11-301-15

15,5 cm / 6 1/8"

Nerv-Präparierschere
Nerve dissecting scissors
Tijeras para disección de nervios
Ciseaux pour nerfs
Forbici per nervi

Feine Präparierscheren

Delicate dissecting scissors

Tijeras finas de disección

Ciseaux fins à dissection

Forbici fini per dissezione

Scheren

Scissors

Tijeras

Ciseaux

Forbici



finoLine

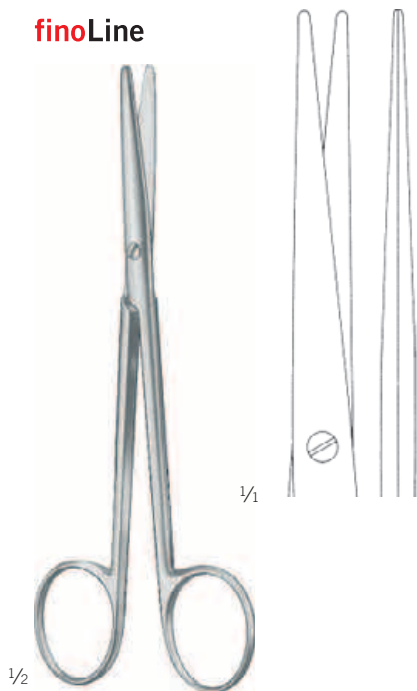

Lexer-Fino
11-324-16

16,5 cm / 6 5/8"

schlankes Modell
slender pattern
modelo delgado
modèle gracile
modello delicato

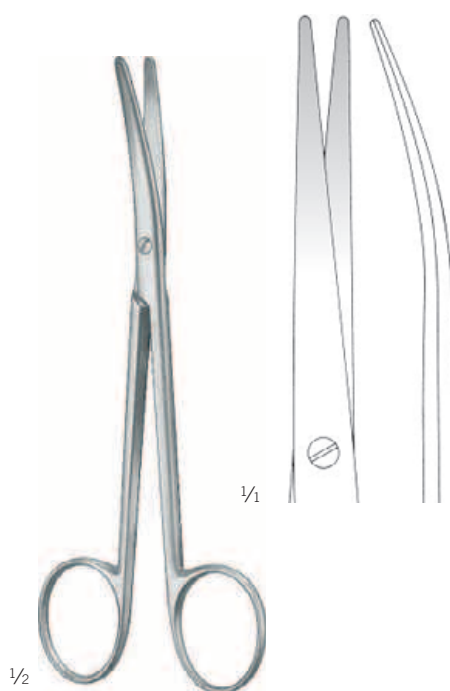

Lexer-Fino
11-325-16

16,5 cm / 6 5/8"

schlankes Modell
slender pattern
modelo delgado
modèle gracile
modello delicato

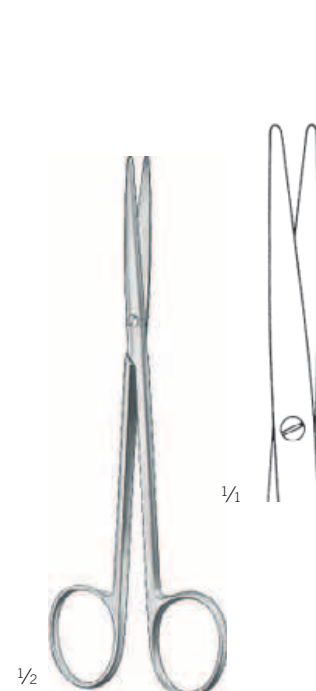

Metzenbaum-Fino
11-326-14

14,5 cm / 5 7/8"

schlankes Modell
slender pattern
modelo delgado
modèle gracile
modello delicato

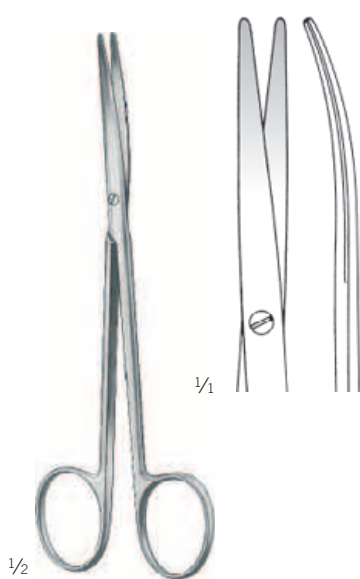

Metzenbaum-Fino
11-327-14

14,5 cm / 5 7/8"

schlankes Modell
slender pattern
modelo delgado
modèle gracile
modello delicato

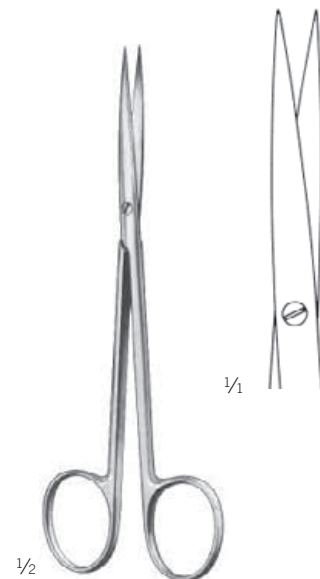

Metzenbaum-Fino
11-328-14

14,5 cm / 5 7/8"

schlankes Modell
slender pattern
modelo delgado
modèle gracile
modello delicato

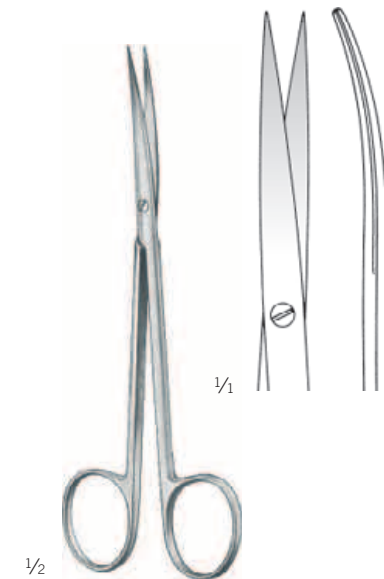

Metzenbaum-Fino
11-329-14

14,5 cm / 5 7/8"

schlankes Modell
slender pattern
modelo delgado
modèle gracile
modello delicato

Feine Präparierscheren

Delicate dissecting scissors

Tijeras finas de disección

Ciseaux fins à dissection

Forbici fini per dissezione

finoLine

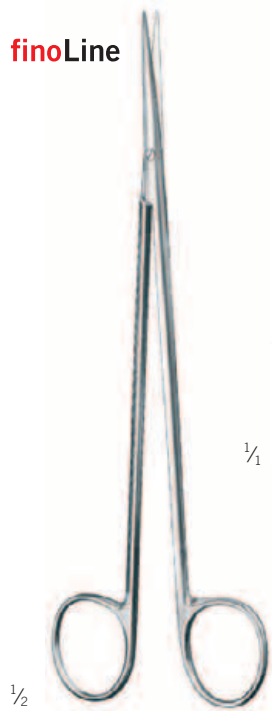

**Metzenbaum-Fino
11-330-18**

18 cm / 7 1/8"

schlankes Modell
slender pattern
modelo delgado
modèle gracile
modello delicato



**Metzenbaum-Fino
11-331-18**

18 cm / 7 1/8"

schlankes Modell
slender pattern
modelo delgado
modèle gracile
modello delicato

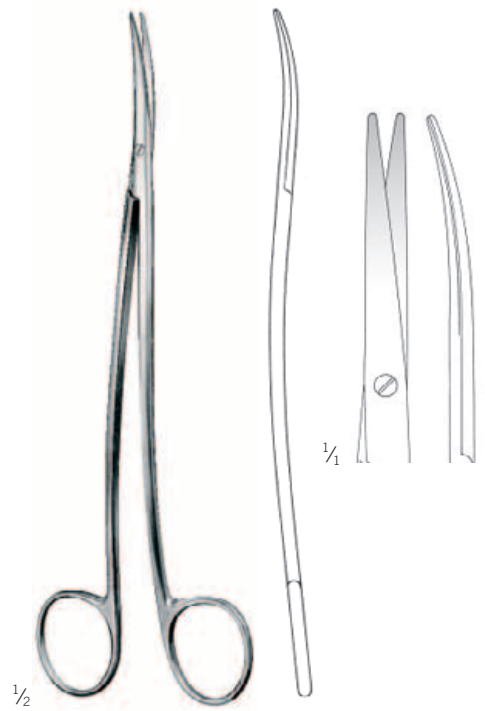

**Metzenbaum-Fino
11-335-18**

18 cm / 7 1/8"

S-förmig gebogen
S shaped
forma S
courbés en S
curve in forma S



11-339-12
12,5 cm / 4 7/8"



11-339-18
18 cm / 7 1/8"

**Salyer
11-339-12 - 11-339-18**

feines Modell für Lippen-, Kiefer-, Gaumenspalte
fine model for cleft palate
modelo fino para fisura paladar
modèle fin pour fente du palais
modello delicato per cheilo-labbro-palato schisi

Präparierscheren, Chirurgische Scheren

Dissecting Scissors, Operating Scissors
 Tijeras de disección, Tijeras quirúrgicas
 Ciseaux à dissection, Ciseaux chirurgicaux
 Forbici per dissezione, Forbici per chirurgia

Scheren

Scissors
 Tijeras
 Ciseaux
 Forbici

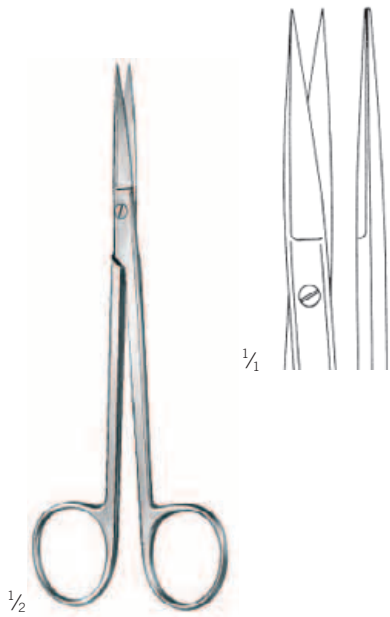
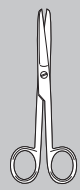

Sanvenero
 11-340-14
 14 cm / 5 4/8"

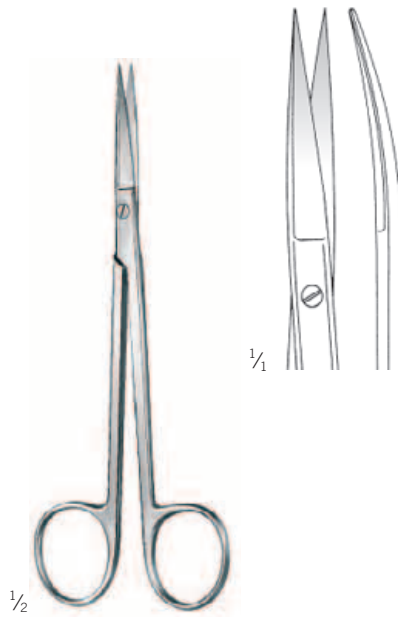

Sanvenero
 11-341-14
 14 cm / 5 4/8"

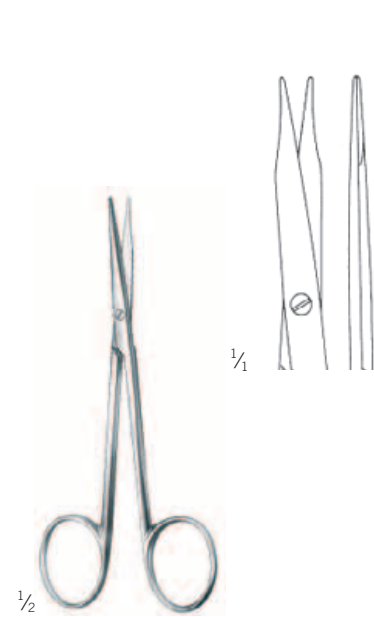

11-344-11
 11 cm / 4 3/8"

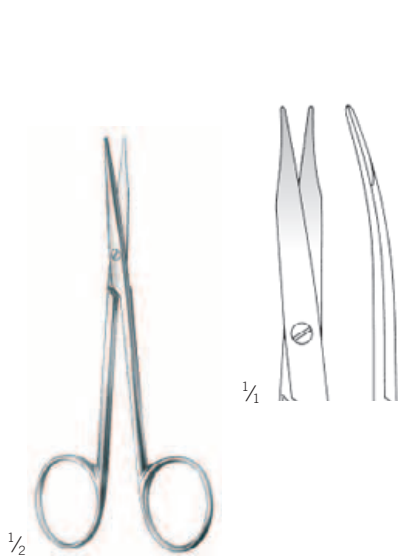

11-345-11
 11 cm / 4 3/8"

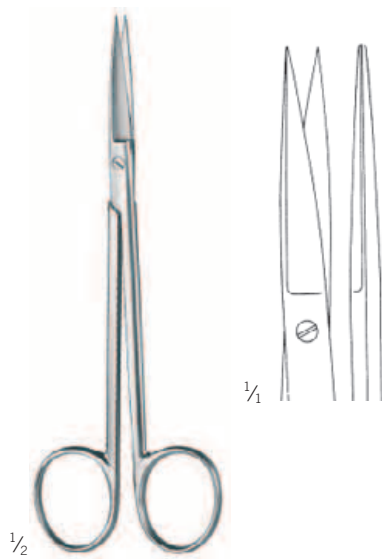

Joseph
 11-350-14
 14,5 cm / 5 6/8"

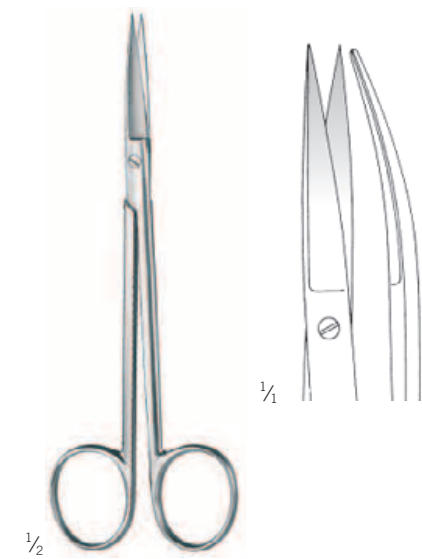

Joseph
 11-351-14
 14,5 cm / 5 6/8"

Präparierscheren, Tonsillenscheren, Zahnfleischscheren

Dissecting scissors, tonsil scissors, gum scissors

Tijeras de disección, tijeras para amígdalas, tijeras para encías

Ciseaux à dissection, ciseaux pour les amygdales, ciseaux pour gencives

Forbici per dissezione, forbici per tonsille, forbici per gengiva

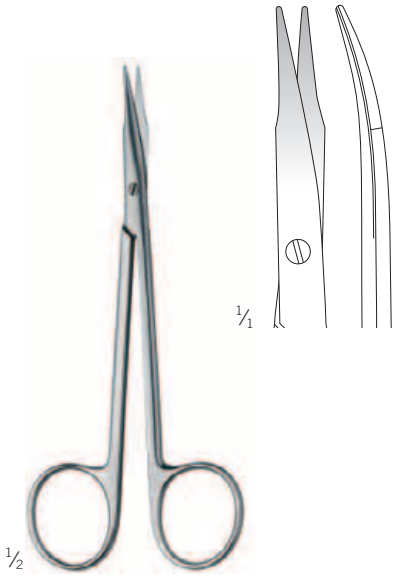

11-358-13
13 cm / 5 1/8"

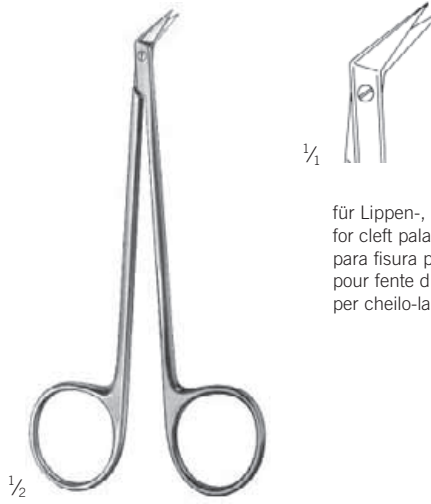

Diethrich-Salyer
11-379-45
12 cm / 4 5/8"

für Lippen-, Kiefer-, Gaumenspalte
for cleft palate
para fisura paladar
pour fente du palais
per cheilo-labbro-palato schisi

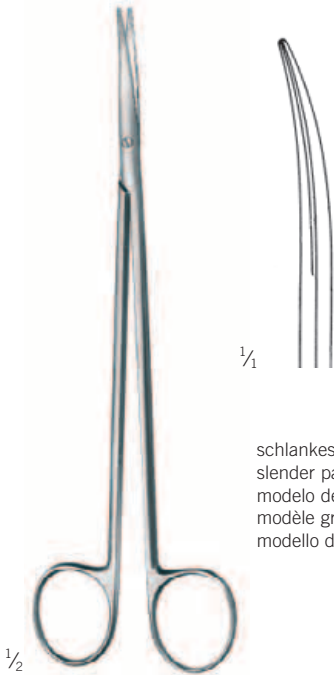

Toennis-Adson
11-459-17
17,5 cm / 6 7/8"

schlankes Modell
slender pattern
modelo delgado
modèle gracile
modello delicato

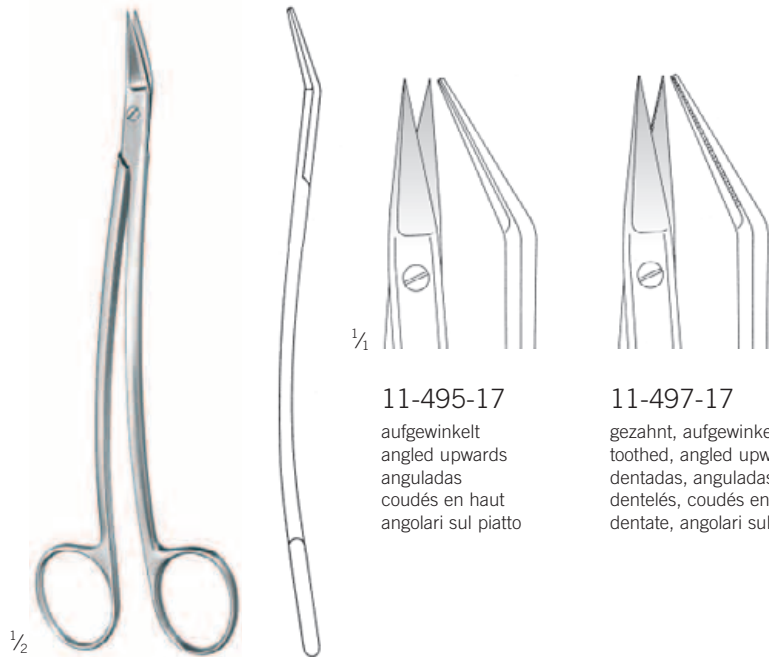

Dean
11-495-17 - 11-497-17
17,5 cm / 6 7/8"

11-495-17
aufgewinkelt
angled upwards
anguladas
coudés en haut
angolari sul piatto

11-497-17
gezahnt, aufgewinkelt
toothed, angled upwards
dentadas, anguladas
dentelés, coudés en haut
dentate, angolari sul piatto

Zahnfleischscheren, chirurgische Scheren

Gum scissors, operating scissors

Tijeras para encías, tijeras quirúrgicas

Ciseaux à gencives, ciseaux chirurgicaux

Forbici per gengiva, forbici per chirurgia

Scheren

Scissors

Tijeras

Ciseaux

Forbici

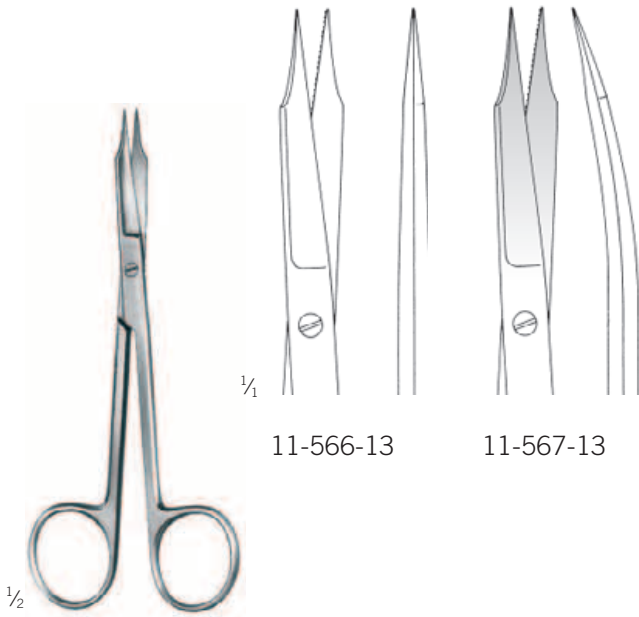
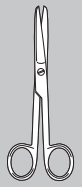

11-566-13

11-567-13

Goldman-Fox
11-566-13 - 11-567-13

13 cm / 5 1/8"

eine Schneide gezahnt
one toothed cutting edge
una hoja dentada
une lame dentelée
una lama dentata



11-570-12

11-571-12

Wagner
11-570-12 - 11-571-12

12 cm / 4 5/8"

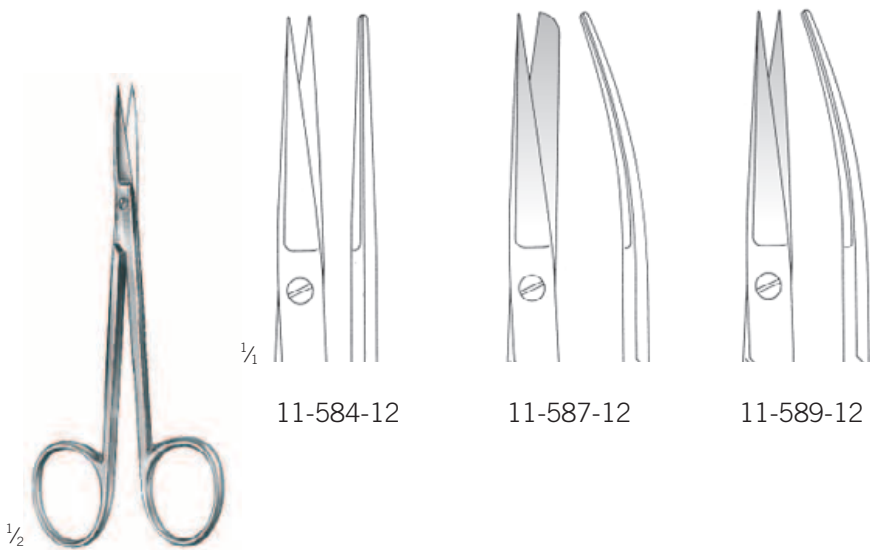

11-584-12

11-587-12

11-589-12

11-584-12 - 11-589-12

12 cm / 4 5/8"

kleines Modell
small model
modelo pequeño
modèle petit
modello piccolo

Zahnfleischscheren, Präparierscheren, chirurgische Scheren

Gum scissors, dissecting scissors, operating scissors

Tijeras para encías, tijeras de disección, tijeras quirúrgicas

Ciseaux à gencives, ciseaux à dissection, ciseaux chirurgicaux

Forbici per gengiva, forbici per dissezione, forbici per chirurgia



La Grange
11-593-11

11,5 cm / 4 1/8"

S-förmig gebogen

S shaped

forma S

courbés en S

curve in forma S



11-594-11



11-595-11

11-594-11 - 11-595-11

11,5 cm / 4 1/8"

fein

delicate

fino

fin

fino

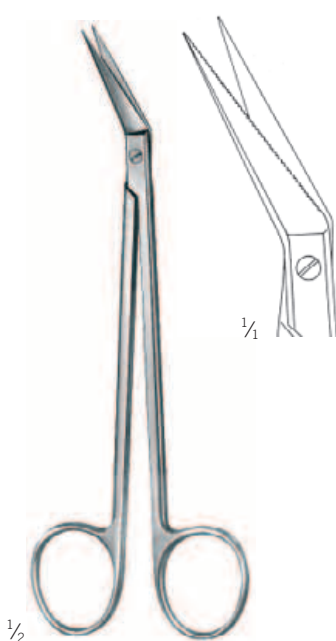

Locklin
11-605-16

16 cm / 6 2/8"

eine Schneide gezahnt

one toothed cutting edge

una hoja dentada

une lame dentelée

una lama dentata

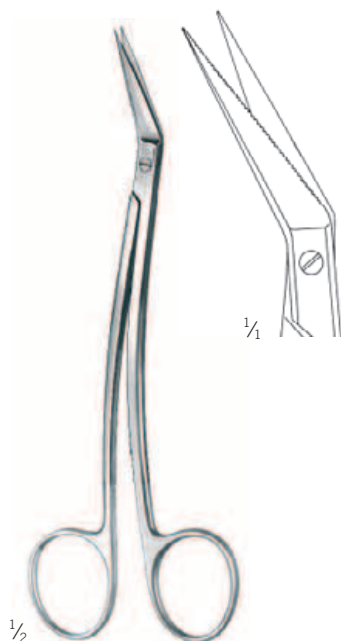

Locklin
11-607-16

16 cm / 6 2/8"

eine Schneide gezahnt

one toothed cutting edge

una hoja dentada

une lame dentelée

una lama dentata



11-618-08

9 cm / 3 1/8"

sehr fein

very delicate

muy fino

très fine

strafine



11-618-08



11-619-08

Irisscheren

Iris scissors
Tijeras para iridectomía
Ciseaux à iridectomie
Forbici per iridectomia

Scheren

Scissors
Tijeras
Ciseaux
Forbici

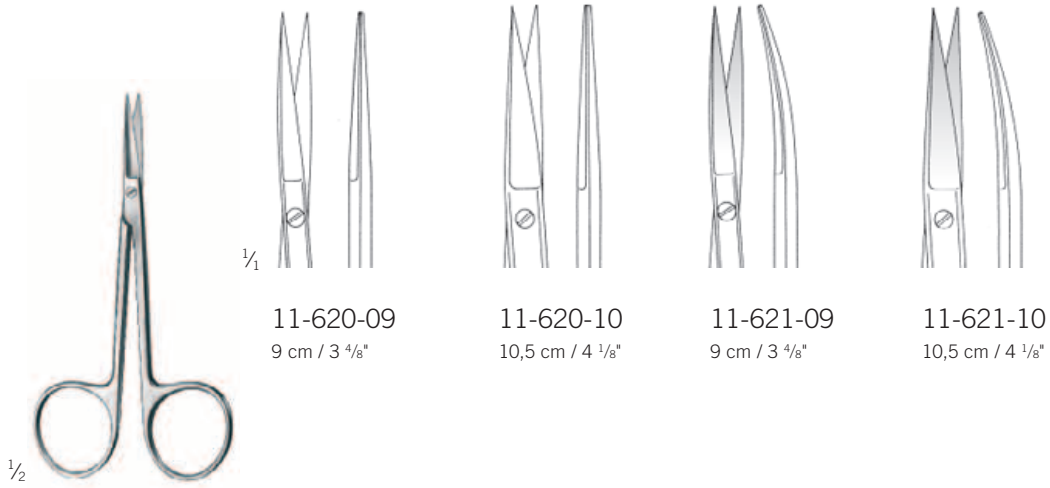
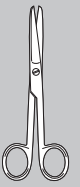

11-620-09 9 cm / 3 4/8"
11-620-10 10,5 cm / 4 1/8"
11-621-09 9 cm / 3 4/8"
11-621-10 10,5 cm / 4 1/8"

11-620-09 - 11-621-10



11-622-10 10,5 cm / 4 1/8"
Bonn 11-624-09 9 cm / 3 4/8"
Bonn 11-625-09 9 cm / 3 4/8"

extra flache Blätter
extra flat blades
hojas muy delgadas
lames extrêmement plates
con lame molto piatte

Irisscheren, Sehnenscheren, Fadenscheren

Iris scissors, tendon scissors, stitch scissors

Tijeras para iridectomía, tijeras para tendones, tijeras para hilos

Ciseaux à iridectomie, ciseaux à ténotomie, ciseaux à ligatures

Forbici per iridectomia, forbici per tenotomia, forbici per legature

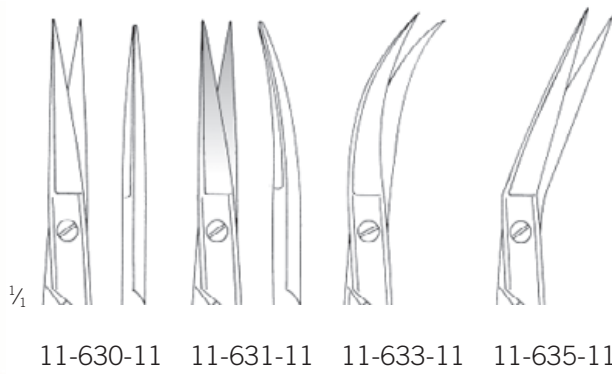

11-630-11 11-631-11 11-633-11 11-635-11

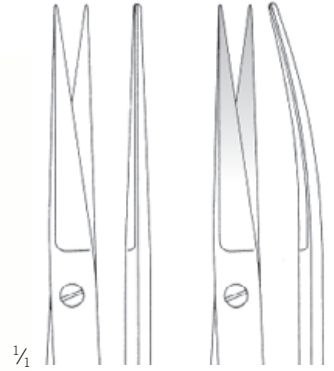
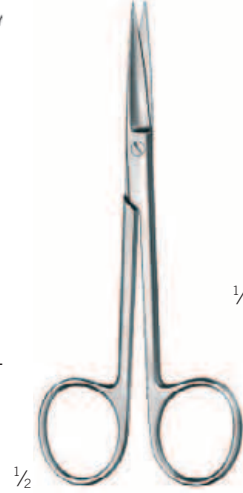

11-640-12 11-641-12

11-630-11 - 11-635-11

11,5 cm / 4 5/8"

11-640-12 - 11-641-12

12,5 cm / 4 7/8"

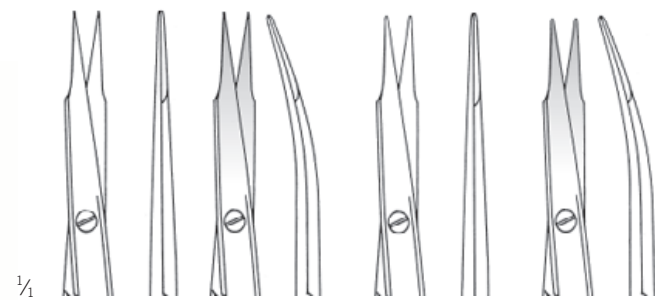

11-680-11 11-681-11 11-682-11 11-683-11
 spitz sharp stump stump
 sharp sharp blunt blunt
 agudo agudo romo romo
 pointu pointu mousse mousse
 appuntato appuntato smusso smusso

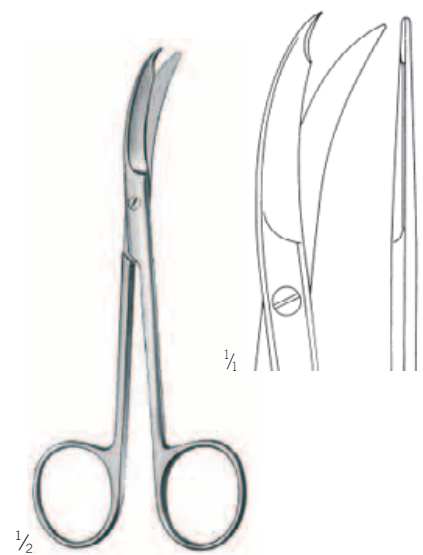

Northbent
 11-819-13

13 cm / 5 1/8"

Stevens
 11-680-11 - 11-683-11

11 cm / 4 3/8"

Fadenscheren, Verbandscheren

Stitch scissors, bandage scissors

Tijeras para hilos, tijeras para vendajes

Ciseaux à ligatures, ciseaux pour pansements

Forbici per legature, forbici per bendaggi

Scheren

Scissors

Tijeras

Ciseaux

Forbici

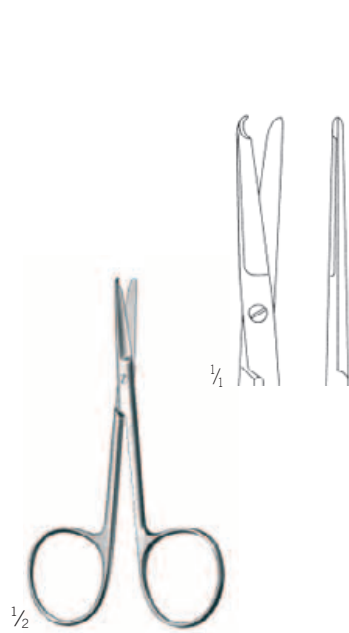
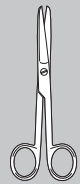

Spencer
11-824-09
9 cm / 3 4/8"

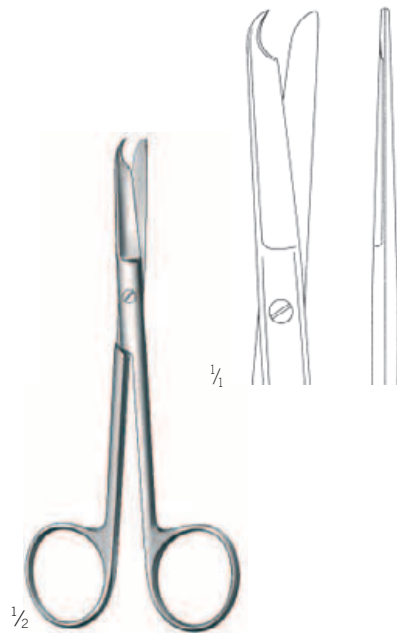

Spencer
11-826-13
13 cm / 5 1/8"

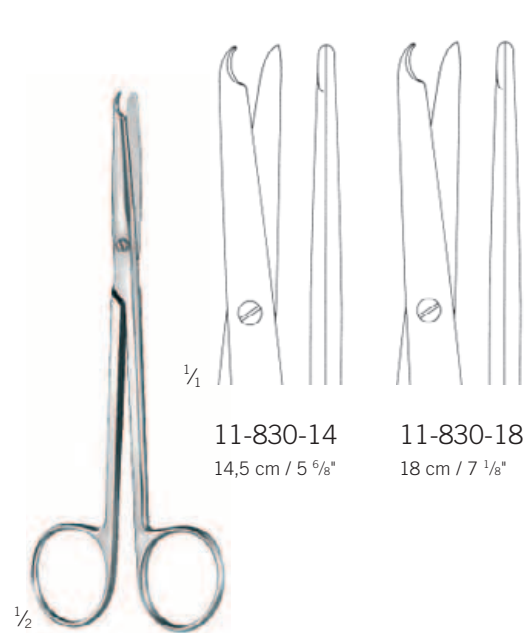

11-830-14
14,5 cm / 5 9/16"

11-830-18
18 cm / 7 1/8"

Buck
11-830-14 - 11-830-18

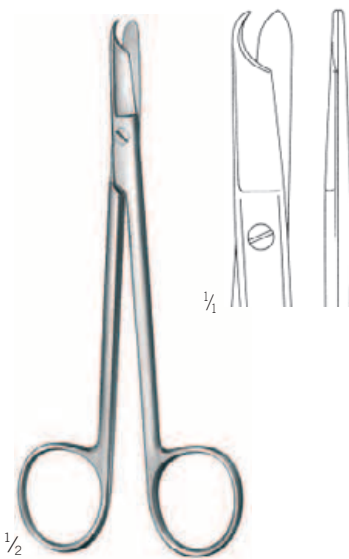

Littauer
11-834-14
14 cm / 5 4/8"

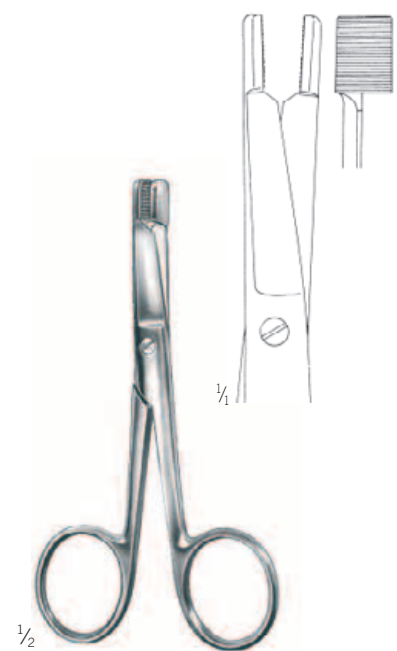

Eiselsberg
11-840-12
12 cm / 4 6/8"

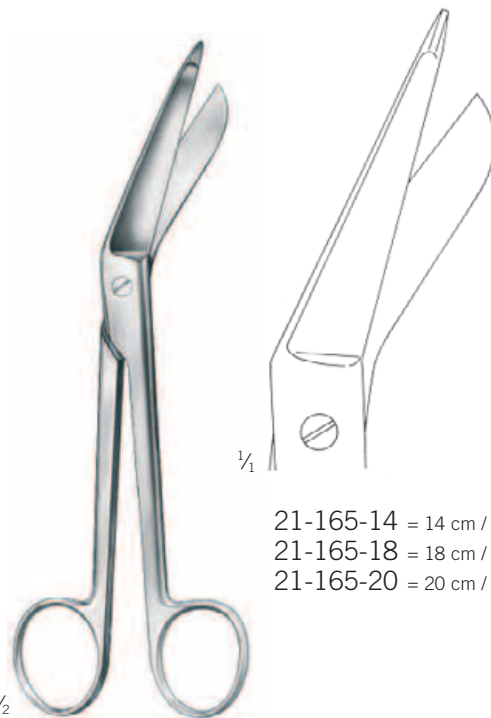

21-165-14 = 14 cm / 5 4/8"

21-165-18 = 18 cm / 7 1/8"

21-165-20 = 20 cm / 7 7/8"

Lister

Mikroscheren

Micro Scissors

Micro-Tijeras

Micro-Ciseaux

Micro-Forbici



1/2

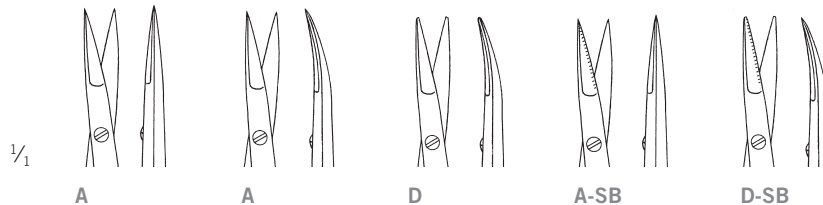

		A	A	D	A-SB	D-SB
		10 mm	10 mm	10 mm	10 mm	10 mm
15 cm / 5 7/8"	St	11-710-15	11-711-15			
15 cm / 5 7/8"	Ti	11-716-15	11-717-15			
18 cm / 7 1/8"	St	11-710-18	11-711-18	11-711-19	11-710-19	11-711-20
18 cm / 7 1/8"	Ti	11-716-18	11-717-18			
21 cm / 8 2/8"	St	11-710-21	11-711-21			
21 cm / 8 2/8"	Ti	11-716-21	11-717-21			
23 cm / 9"	St	11-710-23	11-711-23			



1/2

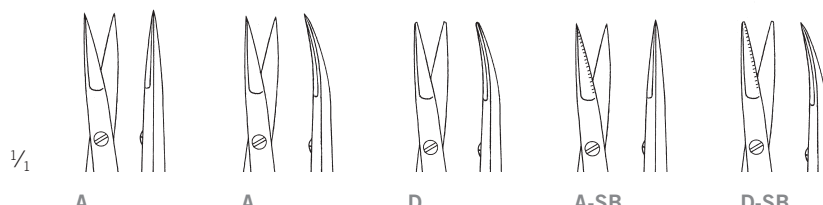

		A	A	D	A-SB	D-SB
		10 mm	10 mm	10 mm	10 mm	10 mm
15 cm / 5 7/8"	St	11-712-15	11-713-15			
15 cm / 5 7/8"	Ti	11-718-15	11-719-15			
18 cm / 7 1/8"	St	11-712-18	11-713-18	11-713-19	11-712-19	11-713-20
18 cm / 7 1/8"	Ti	11-718-18	11-719-18			
21 cm / 8 2/8"	St	11-712-21	11-713-21			
21 cm / 8 2/8"	Ti	11-718-21	11-719-21			
23 cm / 9"	St	11-712-23	11-713-23			

A = Adventitia
D = Präparation
A-SB = Adventitia, ein gezahntes Blatt
D-SB = Präparation, ein gezahntes Blatt

A = Adventitia
D = Dissection
A-SB = Adventitia, one serrated blade
D-SB = Dissection, one serrated blade

A = Adventicia
D = Disección
A-SB = Adventicia, una hoja dentada
D-SB = Disección, una hoja dentada

A = Advantice
D = Dissection
A-SB = Advantice, une lame dentelée
D-SB = Dissection, une lame dentelée

A = Avventizia
D = Dissezione
A-SB = Avventizia, una lama dentata
D-SB = Dissezione, una lama dentata

Mikroscheren

Micro Scissors
Micro-Tijeras
Micro-Ciseaux
Micro-Forbici

Scheren

Scissors
Tijeras
Ciseaux
Forbici

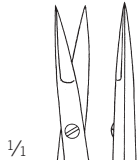
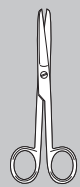

11-714-18
A



11-715-18
A



1/2

Igthaut

11-714-18 - 11-715-18

18 cm / 7 1/8"



11

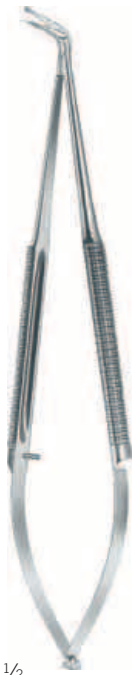

1/4



1/2

JABOMA

11-765-18

18 cm / 7 1/8"

für Lippen-, Kiefer-, Gaumenspalte
for Cleft Palate
para fisura paladar
pour fente du palais
per cheilo-labbro-palato schisi

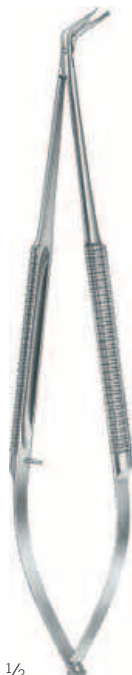

1/4



1/2

JABOMA

11-767-18

18 cm / 7 1/8"

für Lippen-, Kiefer-, Gaumenspalte
for Cleft Palate
para fisura paladar
pour fente du palais
per cheilo-labbro-palato schisi



1/4



1/2

JABOMA

11-769-18

18 cm / 7 1/8"

für Lippen-, Kiefer-, Gaumenspalte
for Cleft Palate
para fisura paladar
pour fente du palais
per cheilo-labbro-palato schisi

Präparierscheren, chirurgische Scheren

Dissecting scissors, operating scissors

Tijeras de disección, tijeras quirúrgicas

Ciseaux à dissection, ciseaux chirurgicaux

Forbici per dissezione, forbici per chirurgia

highMed



11-883-14
14,5 cm / 5 6/8"



11-883-18
18 cm / 7 1/8"

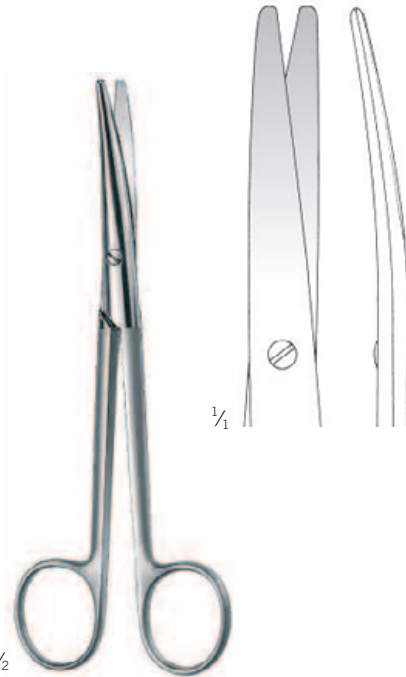

Mayo-Lexer
11-885-16
16 cm / 6 2/8"

Metzenbaum
11-883-14 - 11-883-18

mit Spezialschliff
with special cutting edge
con filo especial
avec affûtage spéciale
con affilatura speciale

TC GOLD

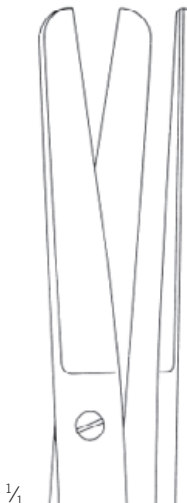

11-902-14

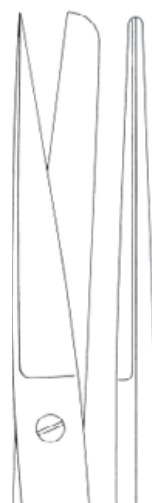

11-904-14



11-906-14

11-902-14 - 11-906-14
14,5 cm / 5 3/4"

Chirurgische Scheren, Ligaturscheren

Operating scissors, ligature scissors
 Tijeras quirúrgicas, tijeras para ligaduras
 Ciseaux chirurgicaux, ciseaux pour ligatures
 Forbici per chirurgia, forbici per legature

Scheren

Scissors
 Tijeras
 Ciseaux
 Forbici

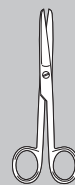

TC GOLD



11-903-14



11-905-14



11-907-14

11-903-14 - 11-907-14
 14,5 cm / 5 3/4"

sutureCut

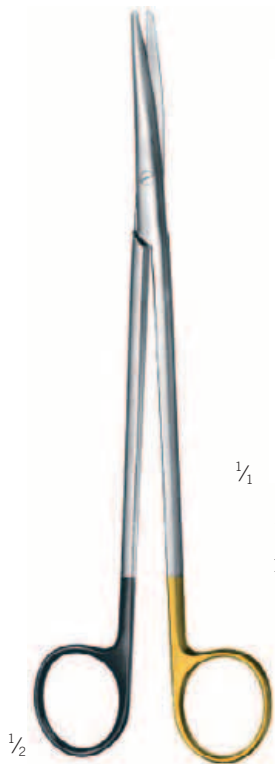

11-914-14
 14,5 cm / 5 3/4"



11-914-18
 18 cm / 7"

11-914-14 - 11-914-18

für Synthetik-Nahtmaterial, eine Schneide gezahnt
 for synthetic suture material, one toothed cutting edge
 para hilos de sutura sintéticos, una hoja dentada
 pour matériel de suture synthétique, une lame dentelée
 per materiale di sutura sintetico, una lama dentata

sutureCut

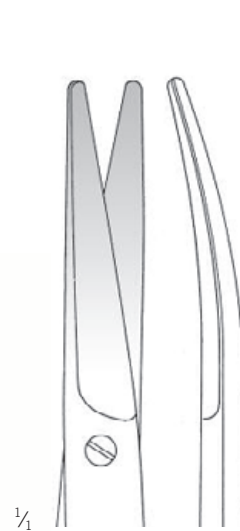
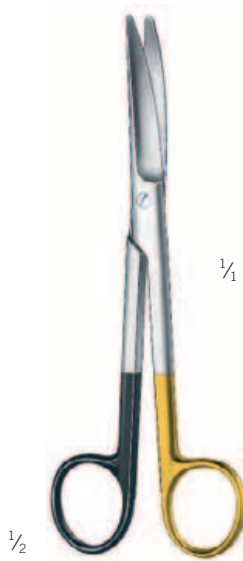

11-915-14
 14,5 cm / 5 3/4"

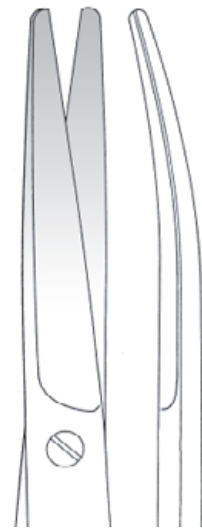

11-915-17
 17 cm / 6 3/4"

11-915-14 - 11-915-17

für Synthetik-Nahtmaterial, eine Schneide gezahnt
 for synthetic suture material, one toothed cutting edge
 para hilos de sutura sintéticos, una hoja dentada
 pour matériel de suture synthétique, une lame dentelée
 per materiale di sutura sintetico, una lama dentata

Präparierscheren, chirurgische Scheren

Dissecting scissors, operating scissors

Tijeras de disección, tijeras quirúrgicas

Ciseaux à dissection, ciseaux chirurgicaux

Forbici per dissezione, forbici per chirurgia

TC GOLD



Metzenbaum
11-936-11 - 11-937-11
11,5 cm / 4 5/8"



Metzenbaum
11-938-14 - 11-939-14
14,5 cm / 5 5/8"

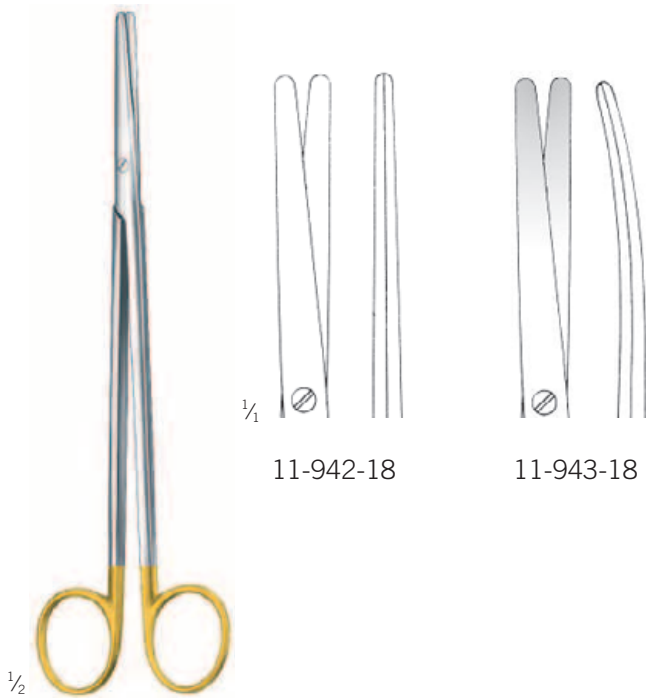

Metzenbaum
11-942-18 - 11-943-18
18 cm / 7 1/8"

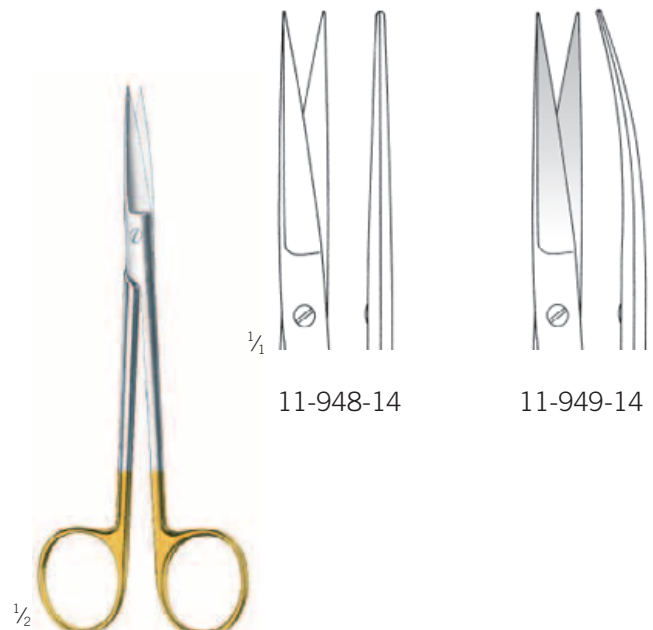

Joseph
11-948-14 - 11-949-14
14,5 cm / 5 5/8"

Präparierscheren

Dissecting scissors
Tijeras de disección
Ciseaux à dissection
Forbici per dissezione

Scheren

Scissors
Tijeras
Ciseaux
Forbici

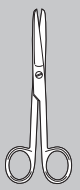

TC GOLD finoLine



11-954-14
14,5 cm / 5 5/8"



11-955-14
14,5 cm / 5 5/8"



11-960-18
18 cm / 7 1/8"



11-961-18
18 cm / 7 1/8"

11

Metzenbaum-Fino 11-954-14 - 11-961-18

schlankes Modell
slender pattern
modelo delgado
modèle gracile
modello delicato

finoLine

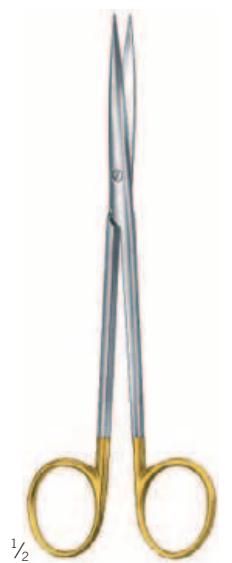

11-956-14
14,5 cm / 5 3/4"



11-957-14
14,5 cm / 5 3/4"



11-962-18
18 cm / 7 1/8"



11-962-20
20 cm / 7 7/8"

Metzenbaum-Fino 11-956-14 - 11-956-20

schlankes Modell
slender pattern
modelo delgado
modèle gracile
modello delicato

Feine Präparierscheren

Delicate dissecting scissors

Tijeras finas de disección

Ciseaux fins à dissection

Forbici fini per dissezione

TC GOLD

finoLine

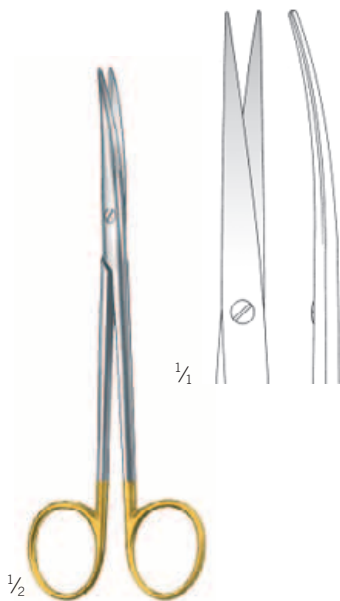

Metzenbaum-Lahey
11-965-14
14,5 cm / 5 6/8"
schlankes Modell
slender pattern
modelo delgado
modèle gracile
modello delicato

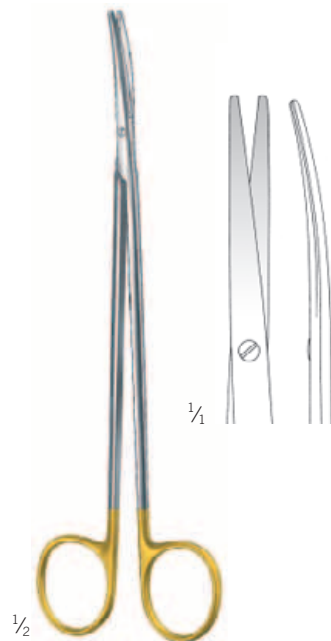

Toennis-Adson
11-965-17
17,5 cm / 6 7/8"
schlankes Modell
slender pattern
modelo delgado
modèle gracile
modello delicato

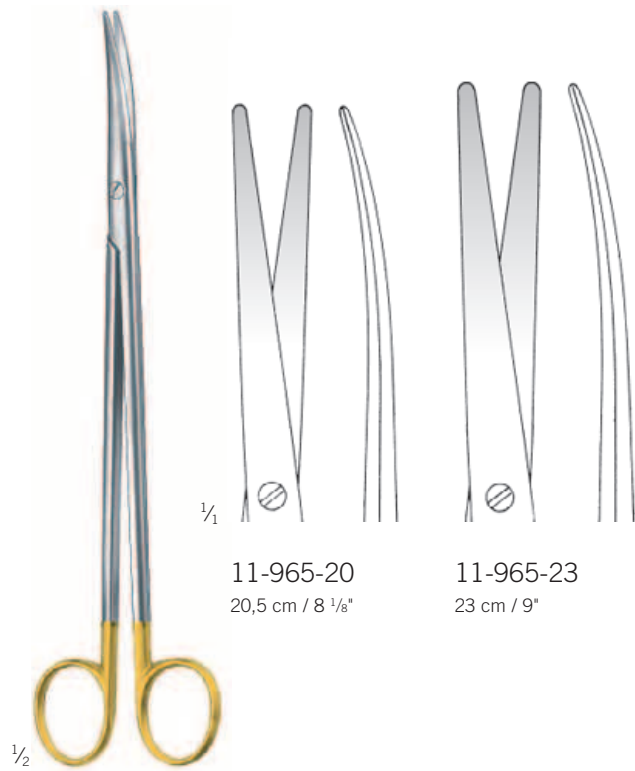

Metzenbaum-Fino
11-965-20 - 11-965-23
schlankes Modell
slender pattern
modelo delgado
modèle gracile
modello delicato

Zahnfleischscheren

Gum scissors
Tijeras para encías
Ciseaux à gencives
Forbici per gengiva

Scheren

Scissors
Tijeras
Ciseaux
Forbici



TC GOLD

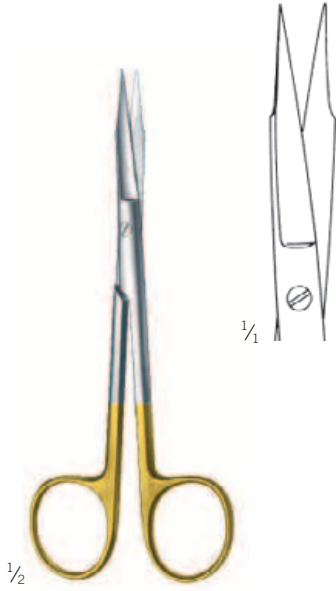

Goldman-Fox
11-980-13
13 cm / 5 1/8"

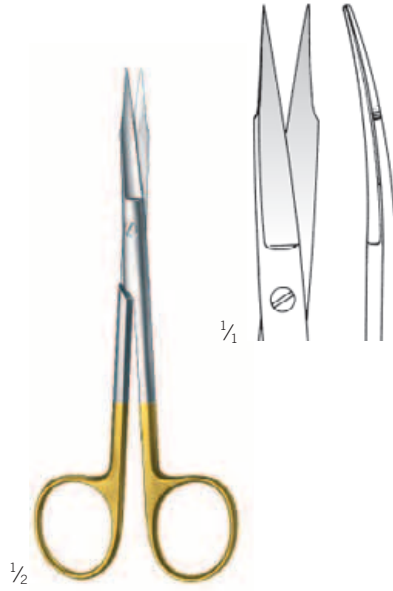

Goldman-Fox
11-981-13
13 cm / 5 1/8"

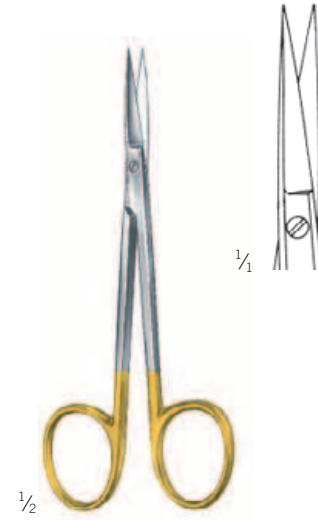

11-982-11
11,5 cm / 4 7/8"



11-983-11
11,5 cm / 4 7/8"

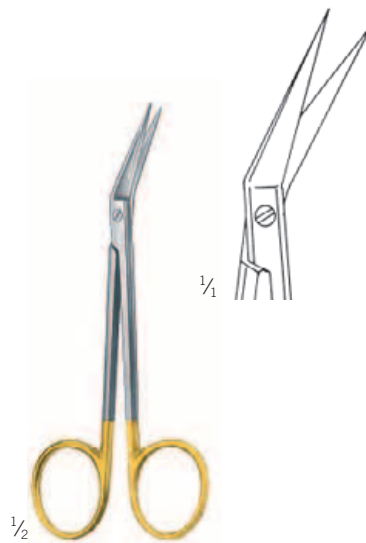

11-989-11
11 cm / 4 3/8"



Ragnell
11-991-12
12,5 cm / 4 7/8"

Zahnfleischscheren

Gum scissors

Tijeras para encías

Ciseaux à gencives

Forbici per gengiva

TC GOLD



Kelly
11-992-16 - 11-992-16
16 cm / 6 2/8"

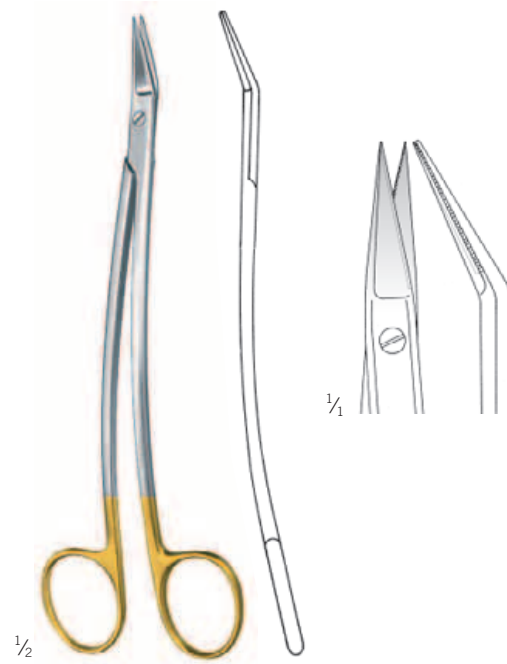

Dean
11-994-17
17,5 cm / 6 7/8"
eine Schneide gezahnt
one toothed cutting edge
una hoja dentada
une lame dentelée
una lama dentata

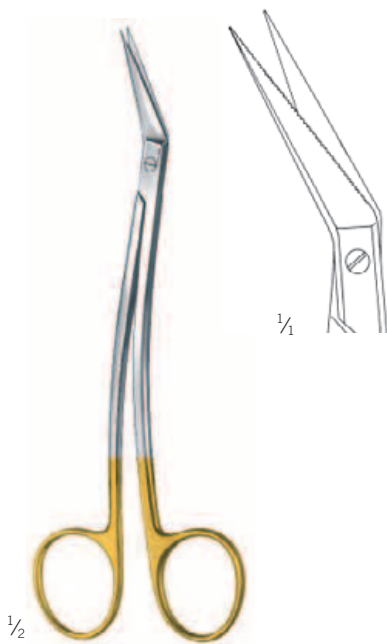

Locklin
11-997-16
16 cm / 6 2/8"
eine Schneide gezahnt
one toothed cutting edge
una hoja dentada
une lame dentelée
una lama dentata

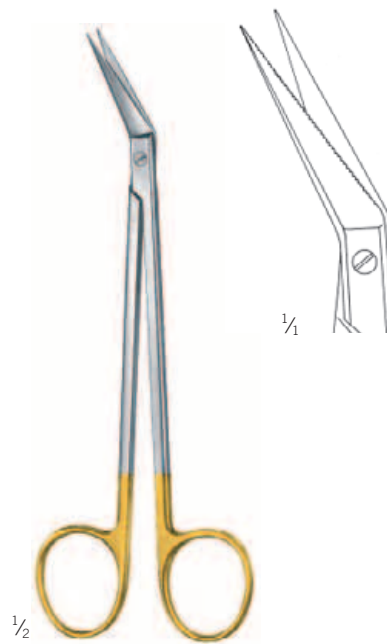

Locklin
11-999-16
16 cm / 6 2/8"
eine Schneide gezahnt
one toothed cutting edge
una hoja dentada
une lame dentelée
una lama dentata

12

Pinzetten

Forceps
Pinzas
Pincers
Pinze



Anatomische Pinzetten

Dissecting forceps, atraumatic dressing forceps

Pinzas de disección, pinzas de disección atraumática

Pinces à dissection, pincés atraumatiques à dissection

Pinze per dissezione, pinze atraumatiche

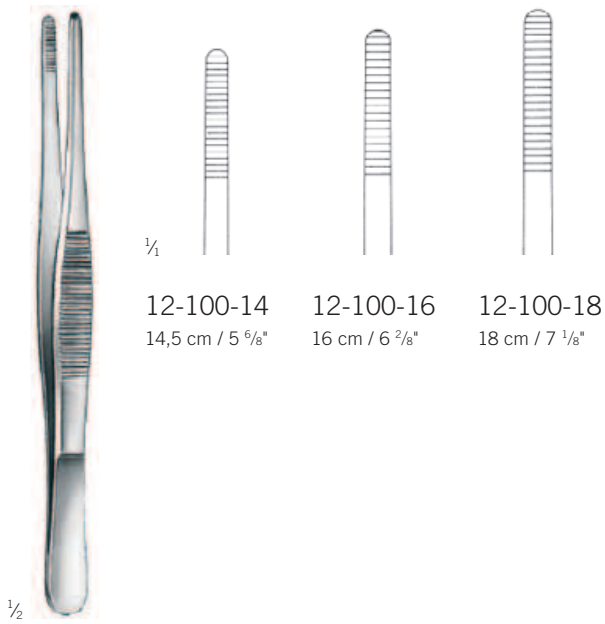

12-100-14 12-100-16 12-100-18
14,5 cm / 5 5/8" 16 cm / 6 2/8" 18 cm / 7 1/8"

12-100-14 - 12-100-18

Standardmodell
standard pattern
modelo estándar
modèle standard
modello standard

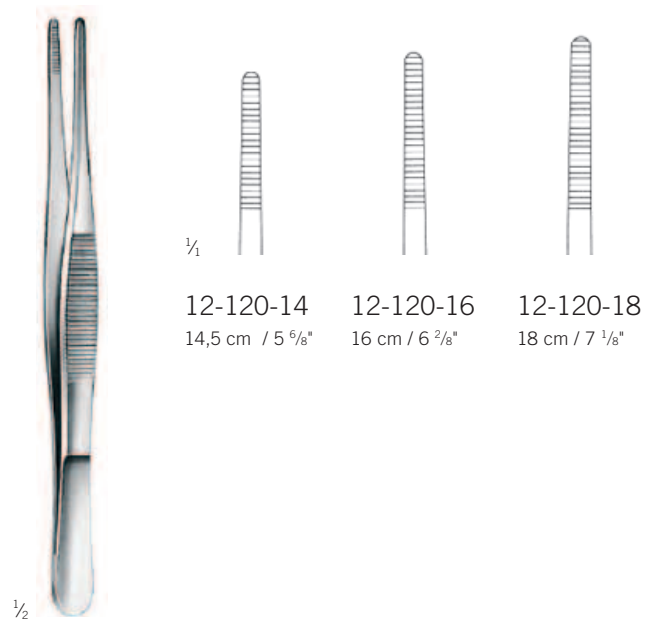

12-120-14 12-120-16 12-120-18
14,5 cm / 5 5/8" 16 cm / 6 2/8" 18 cm / 7 1/8"

12-120-14 - 12-120-18

schlankes Modell
slender pattern
modelo delgado
modèle gracile
modello delicato

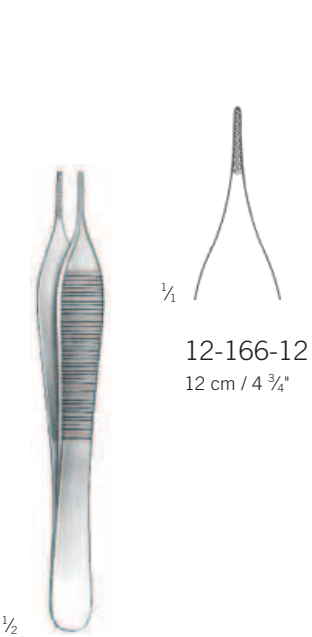

12-166-12
12 cm / 4 3/4"

Mini Adson
12-166-12
12 cm / 4 3/4"

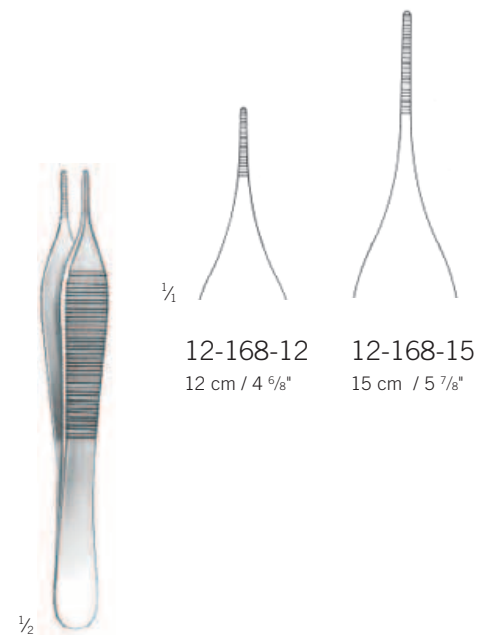

12-168-12 12-168-15
12 cm / 4 5/8" 15 cm / 5 7/8"

Adson
12-168-12 - 12-168-15

Anatomische Pinzetten

Dissecting Forceps
Pinzas de disección
Pincès à dissection
Pinze per dissezione

Pinzetten

Forceps
Pinzas
Pincès
Pinze

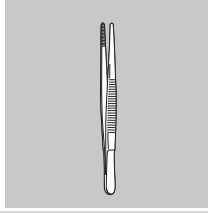

12-172-12 12,5 cm / 4 7/8"
12-172-15 15 cm / 5 7/8"

Semken
12-172-12 - 12-172-15

Taylor
12-174-17
17 cm / 6 5/8"

Atrauma

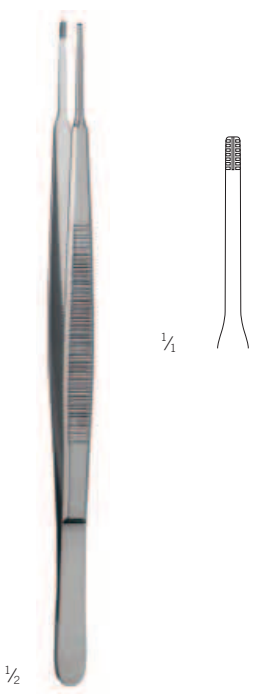

12-184-18
17,5 cm / 6 7/8"

Chirurgische Pinzetten, atraumatische Pinzetten

Dissecting forceps, atraumatic dressing forceps

Pinzas de disección, pinzas de disección atraumática

Pinces à dissection, pincers atraumatiques à dissection

Pinze per dissezione, pinze atraumatiche

TC GOLD

Atrauma



12-236-15
15,5 cm / 6 1/8"
Miniprofil
mini profile
perfil mini
profil mini
mini profilo

Gillies
12-236-15
15,5 cm / 6"

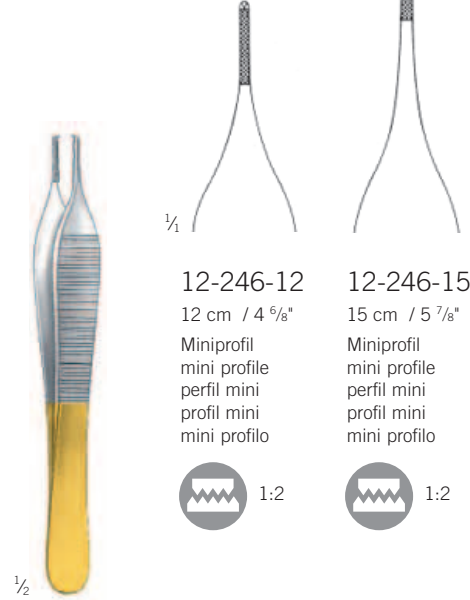

12-246-12
12 cm / 4 9/8"
Miniprofil
mini profile
perfil mini
profil mini
mini profilo

12-246-15
15 cm / 5 7/8"
Miniprofil
mini profile
perfil mini
profil mini
mini profilo

Adson

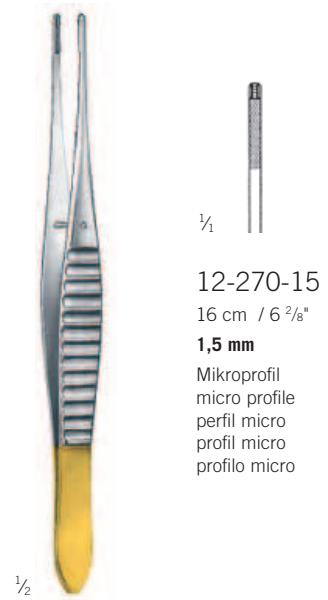

12-270-15
16 cm / 6 2/8"
1,5 mm
Mikroprofil
micro profile
perfil micro
profil micro
profilo micro

DeBakey
12-270-15
16 cm / 6 1/4"

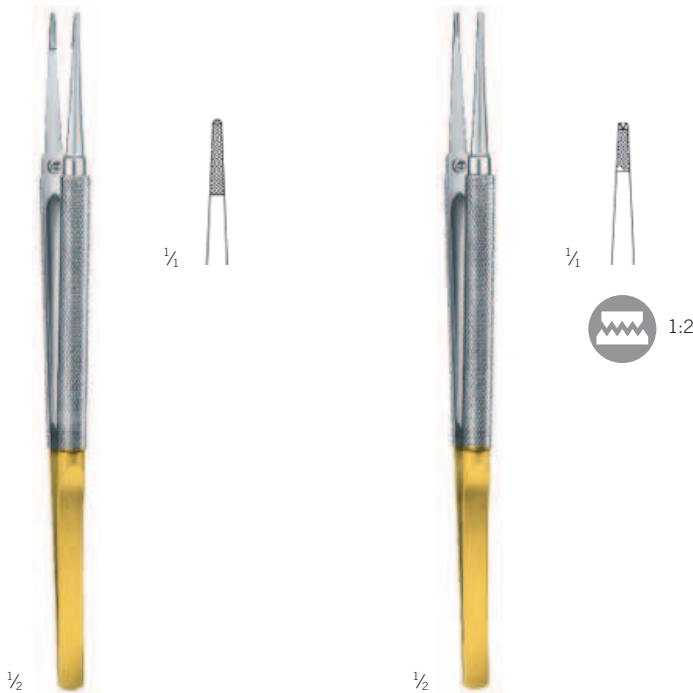

Jaboma
12-276-18
18 cm / 7 1/8"

Jaboma
12-278-18
18 cm / 7 1/8"

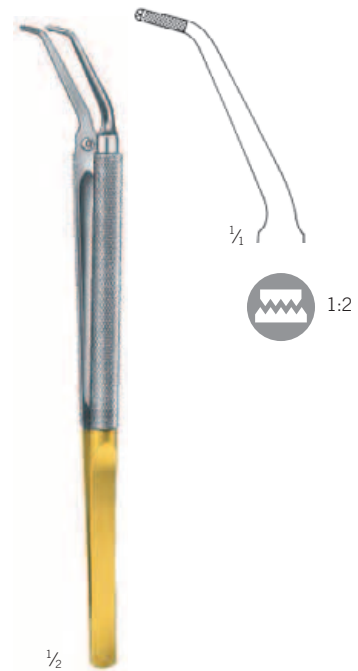

Jaboma
12-279-18
18 cm / 7 1/8"

Chirurgische Pinzetten

Tissue Forceps

Pinzas de disección con diente

Pinces à dissection à griffes

Pinze per dissezione con denti

Pinzetten

Forceps

Pinzas

Pinces

Pinze



12



12-301-14
14,5 cm / 5 7/8"

12-301-16
16 cm / 6 2/8"

12-301-18
18 cm / 7 1/8"

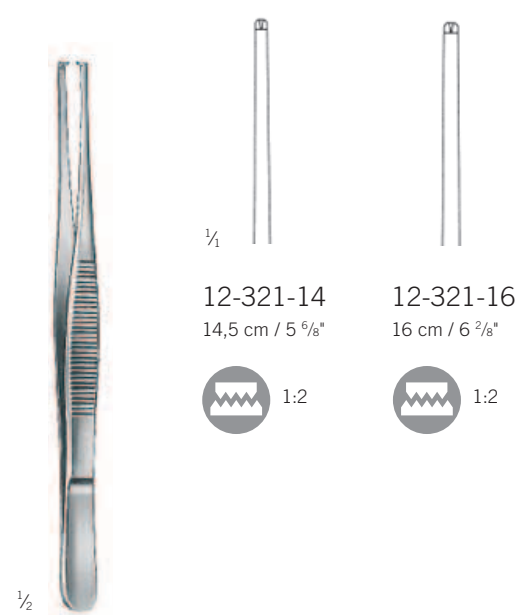

12-321-14
14,5 cm / 5 7/8"

12-321-16
16 cm / 6 2/8"



12-301-14 - 12-301-18

Standardmodell
standard pattern
modelo estándar
modèle standard
modello standard

12-321-14 - 12-321-16

schlankes Modell
slender pattern
modelo delgado
modèle gracile
modello delicato

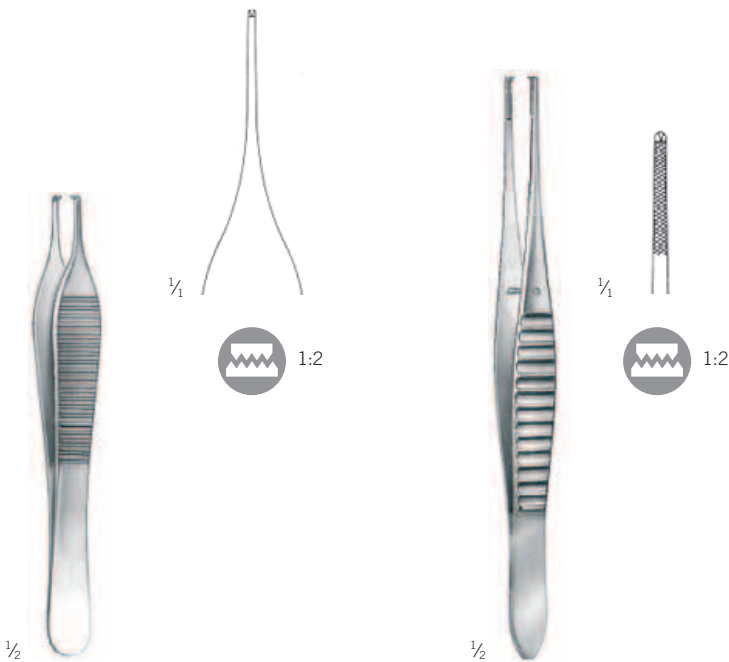

Adson
12-368-15
15 cm / 5 7/8"

Gillies
12-370-15
15,5 cm / 6 1/8"

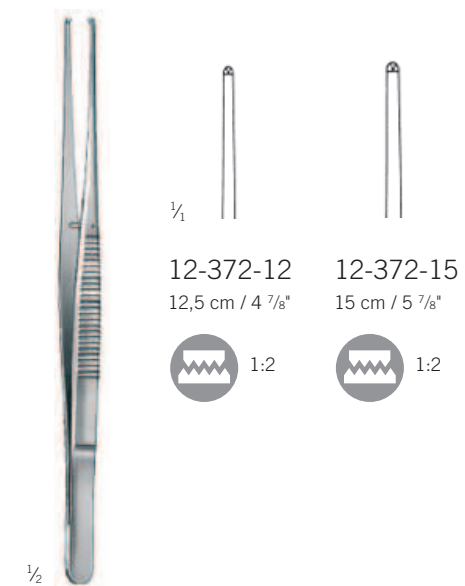

12-372-12
12,5 cm / 4 7/8"

12-372-15
15 cm / 5 7/8"



Semken
12-372-12 - 12-372-15

Chirurgische Pinzetten, Anatomische Pinzetten

Tissue Forceps, Dissecting Forceps

Pinzas de disección con diente, Pinzas de disección

Pinces à dissection à griffes, Pinces à dissection

Pinze per dissezione con denti, Pinze per dissezione

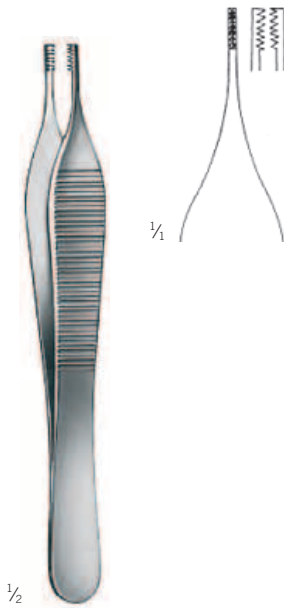

Adson-Brown
12-400-12
12 cm / 4 5/8"

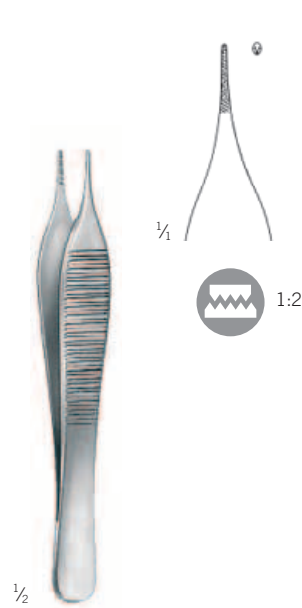

Mini Adson
12-402-12
12 cm / 4 5/8"

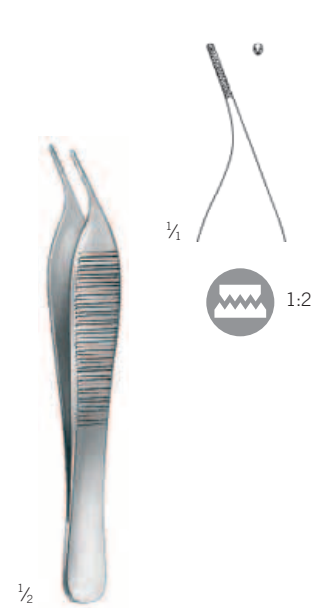

Mini Adson
12-403-12
12 cm / 4 5/8"

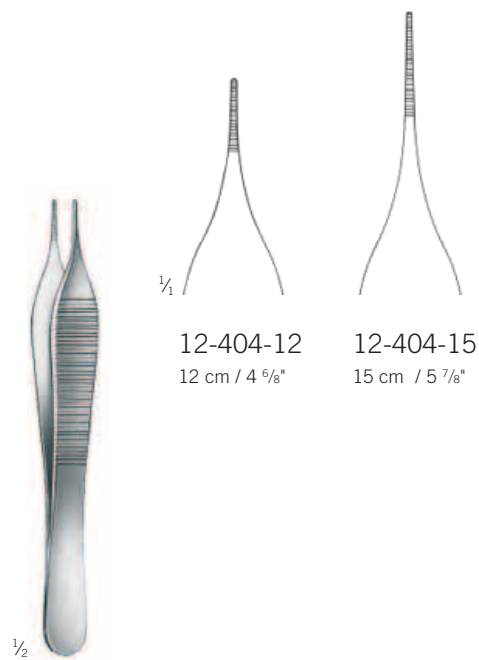

Mikro Adson
12-404-12 - 12-404-15

Anatomische Pinzette
Dressing forceps
Pinza de disección
Pince à dissection
Pinza per dissezione

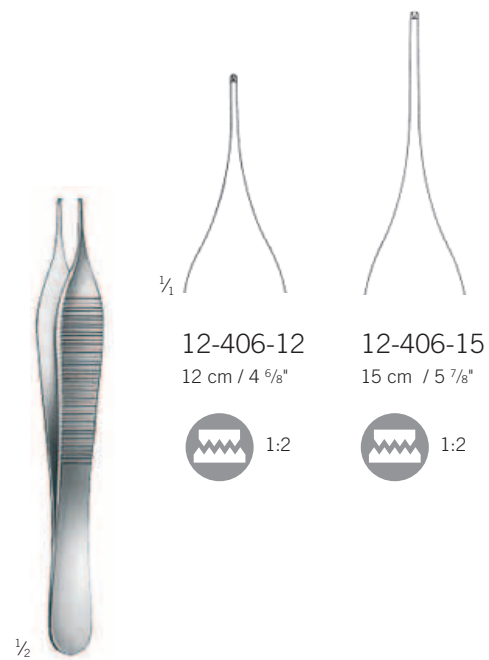

Mikro Adson
12-406-12 - 12-406-15

Mikropinzetten

Micro Forceps
Micro Pinzas
Micro-Pinces
Micro-Pinze

Pinzetten

Forceps
Pinzas
Pinces
Pinze



1/4

12-560-18	12-561-18	12-562-18	12-563-18
0.70 mm	0.70 mm	0.70 mm	0.70 mm
		1:2	1:2

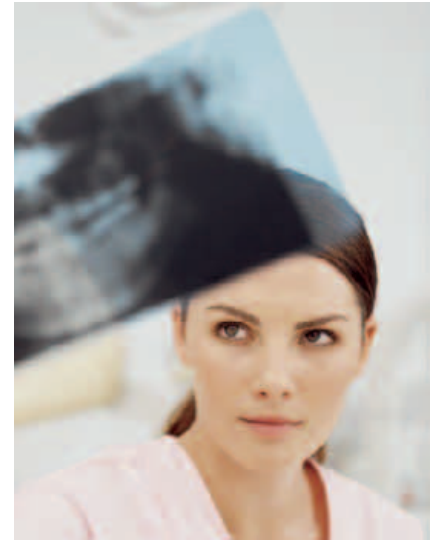

12

1/2

Igthaut
12-560-18 - 12-563-18
18 cm / 7 1/8"



1/1

--	--	--	--	--	--	--

		0.40 mm	0.40 mm	0.70 mm	0.70 mm	0.80 mm	0.80 mm
15 cm / 5 7/8"	St	12-564-15	12-565-15	12-566-15	12-567-15		
15 cm / 5 7/8"	Ti	12-578-15	12-579-15			12-580-15	12-581-15
18 cm / 7 1/8"	St	12-564-18	12-565-18	12-566-18	12-567-18		
18 cm / 7 1/8"	Ti	12-578-18	12-579-18			12-580-18	12-581-18
21 cm / 8 2/8"	St			12-566-21	12-567-21		
21 cm / 8 2/8"	Ti					12-580-21	12-581-21
23 cm / 9"	St			12-566-23	12-567-23		

1/2

VD = Gefäßdilator
Vascular Dilator
Dilatador vascular
Dilatateur vasculaire
Dilatatore vascolare

Mikropinzetten

Micro Forceps

Micro Pinzas

Micro-Pinces

Micro-Pinze



diamond-coated



1/2



		0.40 mm	0.40 mm	0.70 mm	0.70 mm	0.80 mm	0.80 mm
15 cm / 5 7/8"	St	12-568-15	12-569-15	12-570-15	12-571-15		
15 cm / 5 7/8"	Ti	12-582-15	12-583-15			12-584-15	12-585-15
18 cm / 7 1/8"	St	12-568-18	12-569-18	12-570-18	12-571-18		
18 cm / 7 1/8"	Ti	12-582-18	12-583-18			12-584-18	12-585-18
21 cm / 8 2/8"	St			12-570-21	12-571-21		
21 cm / 8 2/8"	Ti					12-584-21	12-585-21
23 cm / 9"	St			12-570-23	12-571-23		



1/2

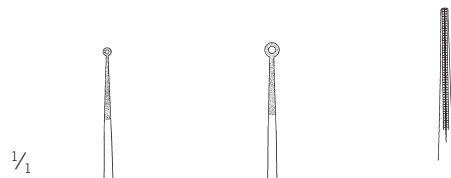

Atrauma

		R Ø 1.0 x 0.5 mm	R Ø 2.0 x 1.0 mm	1.2 mm	
15 cm / 5 7/8"	St	12-574-15	12-576-15	12-589-15	
15 cm / 5 7/8"	Ti	12-586-15	12-588-15	12-590-15	
18 cm / 7 1/8"	St	12-574-18	12-576-18	12-589-18	
18 cm / 7 1/8"	Ti	12-586-18	12-588-18	12-590-18	
21 cm / 8 2/8"	St	12-574-21	12-576-21	12-589-21	
21 cm / 8 2/8"	Ti	12-586-21	12-588-21	12-590-21	
23 cm / 9"	St	12-574-23	12-576-23		

VD = Gefäßdilator
 Vascular Dilator
 Dilatador vascular
 Dilatateur vasculair
 Dilatatore vascolare

Gefäßpinzetten

Vascular forceps

Pinzas de disección vasculares

Pinces à dissection vasculaires

Pinze per dissezione vascolari

Pinzetten

Forceps

Pinzas

Pinces

Pinze



DeBakey
24-384-16
16 cm / 6 2/8"
2,7 mm



DeBakey
24-386-16
16 cm / 6 2/8"
1,5 mm



DeBakey
24-388-16
16 cm / 6 2/8"
2,0 mm



DeBakey
24-389-16
16 cm / 6 2/8"
2,0 mm



DeBakey
24-390-16
16 cm / 6 2/8"
3,5 mm

Zahnpinzetten

Dental forceps

Pinzas

Précelles

Pinze



1/2



1/4

43-031-01
No. 1



43-031-03
No. 3



43-031-05
No. 5



1/2



1/4

43-037-05
No. 5

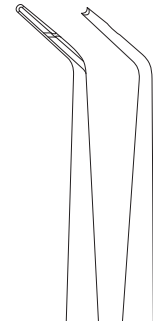

43-037-08
No. 8

für Silberspitzen
for silver points
para puntas de plata
pour cônes d'argent
per punte d'argento

London-College
43-031-01 - 43-031-05
15 cm / 5 7/8"

London-College
43-037-05 - 43-037-08
15 cm / 5 7/8"
mit Sperre
with lock
con cierre
avec serrure
con fermo



1/2

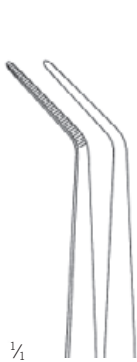

1/4

43-101-01
No. 1



43-101-03
No. 5



43-101-05
No. 5

Meriam
43-101-01 - 43-101-05
16 cm / 6 2/8"

Zahnpinzetten

Dental forceps

Pinzas

Précèlles

Pinze

Pinzetten

Forceps

Pinzas

Pinces

Pinze

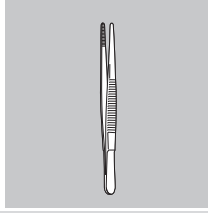

12



1/2

Flagg
43-107-01
16 cm / 6 2/8"

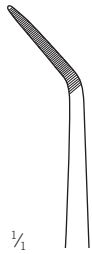

1/4

43-107-01
No. 1

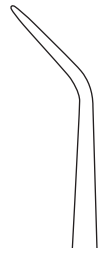

43-107-02
No. 2



43-107-03
No. 3



43-107-04
No. 4



1/2

Martin
43-114-16
16 cm / 6 2/8"

D = 1,6 mm

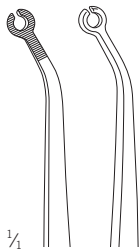

1/4

Naht- und Membranpinzette
Suture and membrane forceps
Pinzas para suturas y membranas
Pincettes à suture et à membrane
Pinzette per membrana e sutura



1/2

Martin
43-116-16
16 cm / 6 2/8"

D = 2,2 mm

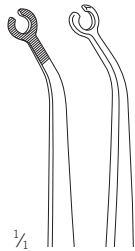

1/4

Naht- und Membranpinzette
Suture and membrane forceps
Pinzas para suturas y membranas
Pincettes à suture et à membrane
Pinzette per membrana e sutura



1/2

Martin
43-118-17
16 cm / 6 2/8"

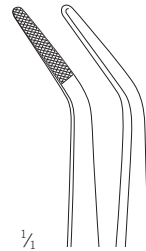

1/4

Zahnpinzetten, Splitterzangen

Dental forceps, splinter forceps

Pinzas, pinzas para espinas

Précettes, pincès à échardes

Pinze, pinze per scheggie

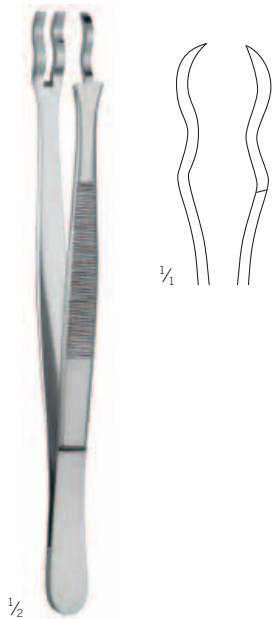

Martin
43-199-00

15 cm / 5 7/8"

Instrumentenfass- und Sterilisierpinzette
Instrument grasping and sterilizing forceps
Pinzas de esterilización y portainstrumentos
Pincettes de prise d'instrument et de stérilisation
Pinzette di sterilizzazione e portastrumenti

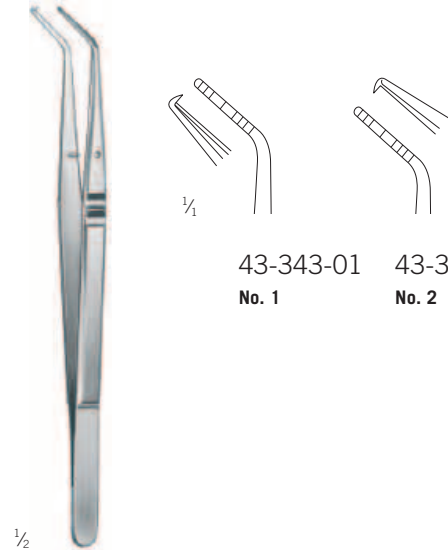

43-343-01

No. 1

43-343-02

No. 2

Crane-Kaplan
43-343-01 - 43-343-02

15 cm / 5 7/8"

Taschenmarkierpinzette
Pocket marking forceps
Pinzas para marcar bolsas
Pincettes de marquage de poche
Pinzette di marcatura delle tasche

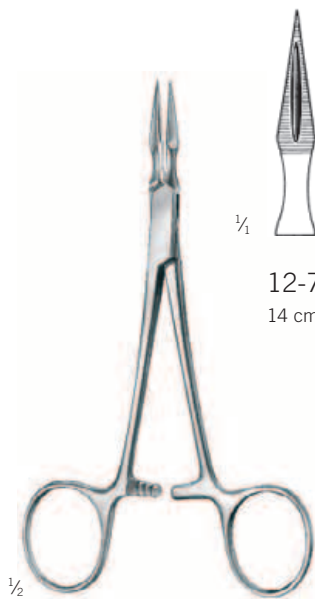

Stieglitz
12-720-13 - 12-721-13

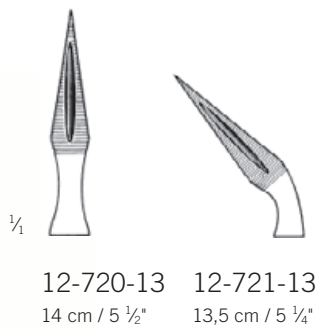

12-720-13

14 cm / 5 1/2"

12-721-13

13,5 cm / 5 1/4"

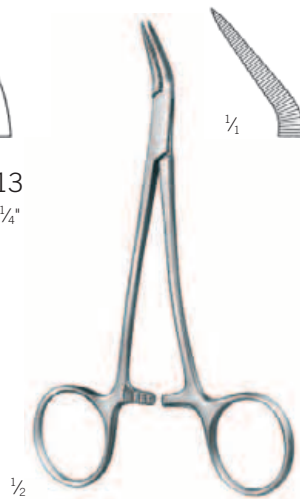

Peet
12-725-11
12,5 cm / 4 7/8"



Ralk
12-740-15 - 12-741-15

12-740-15

15 cm / 5 7/8"

12-741-15

14 cm / 5 4/8"

13

Arterienklemmen

Haemostatic Forceps

Pinzas hemostáticas

Pinces hémostatiques

Pinze emostatiche

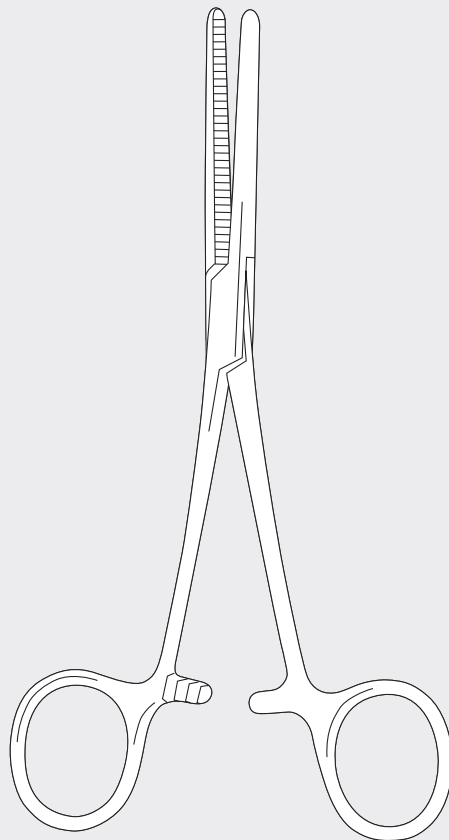

Arterienklemmen

Haemostatic Forceps
Pinzas hemostáticas
Pincas hémostatiques
Pinze emostatiche



1/2

Pean
13-176-14 - 13-176-16

1/1



13-176-14
14,5 cm / 5 7/8"



13-176-16
16 cm / 6 2/8"

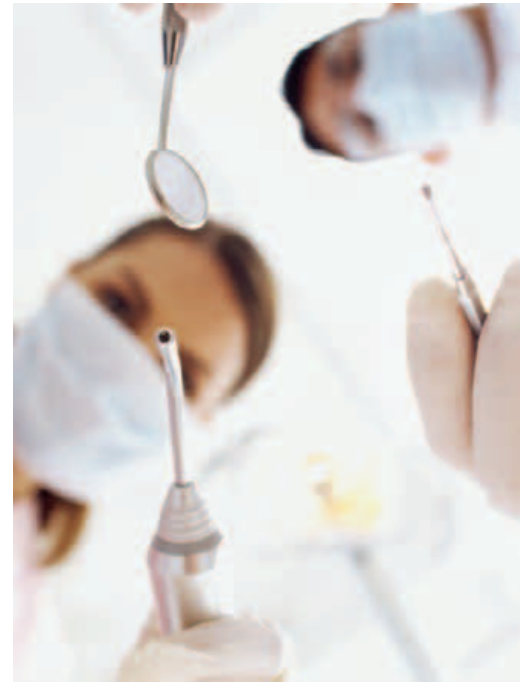

1/1



13-310-12
12,5 cm / 4 7/8"



13-310-14
14,5 cm / 5 6/8"



13-311-14
14 cm / 5 4/8"



13-312-12
12,5 cm / 4 7/8"



13-312-14
14,5 cm / 5 6/8"



13-313-12
12,5 cm / 4 7/8"



13-313-14
14,5 cm / 5 6/8"



1:2



1:2



1:2



1:2



1/2

Halsted-Mosquito
13-310-12 - 13-313-14

Arterienklemmen

Haemostatic Forceps
Pinzas hemostáticas
Pincès hémostatiques
Pinze emostatiche

Arterienklemmen

Haemostatic Forceps
Pinzas hemostáticas
Pincès hémostatiques
Pinze emostatiche



1/2

Halsted-Mosquito

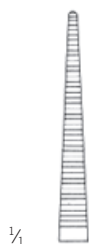

1/4

13-316-18
18,5 cm / 7 2/8"



13-317-18
18 cm / 7 1/8"



13-318-18
18,5 cm / 7 2/8"



13-319-18
18 cm / 7 1/8"



1:2



1:2



1/4

13-320-10
10 cm / 3 7/8"



13-320-12
12 cm / 4 6/8"



13-321-10
10 cm / 3 7/8"



13-321-12
12 cm / 4 6/8"



13-322-10
10 cm / 3 7/8"



13-322-12
12 cm / 4 6/8"



13-323-10
10 cm / 3 7/8"



13-323-12
12 cm / 4 6/8"



1:2



1:2



1:2



1:2

1/2

Mikro Mosquito
13-320-10 - 13-323-12

Arterienklemmen, Präparierklemmen

Haemostatic Forceps, Dissecting and Ligature Forceps

Pinzas hemostáticas, Pinzas para preparación y ligadura

Pinces hémostatiques, Pinces à dissecquer et à ligatures

Pinze emostatiche, Pinze per preparazioni e legature



1/2

Leriche
13-326-15 - 13-329-15



1/4

13-326-15
15,5 cm / 6 1/8"



13-327-15
15 cm / 5 7/8"



13-328-15
15,5 cm / 6 1/8"



1:2



13-329-15
15 cm / 5 7/8"



1:2

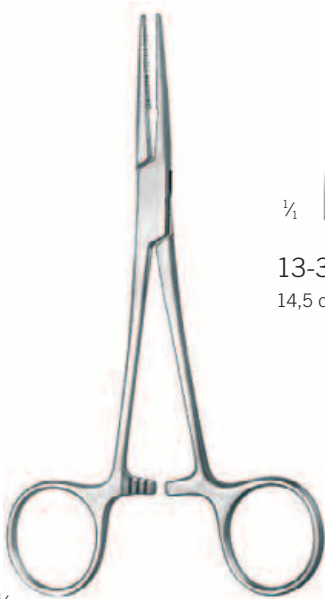

1/2

Kelly
13-330-14 - 13-331-14



1/4

13-330-14
14,5 cm / 5 9/8"



13-331-14
14 cm / 5 4/8"



1/2

Adson
13-364-18 - 13-365-18



1/4

13-364-18
19 cm / 7 4/8"



13-365-18
18,5 cm / 7 2/8"

Arterienklemmen, Präparierklemmen

Haemostatic Forceps, Dissecting and Ligature Forceps
 Pinzas hemostáticas, Pinzas para preparación y ligadura
 Pincès hémostatiques, Pincès à dissecquer et à ligatures
 Pinze emostatiche, Pinze per preparazioni e legature

Arterienklemmen

Haemostatic Forceps
 Pinzas hemostáticas
 Pincès hémostatiques
 Pinze emostatiche



1/2

Pean
 13-374-13 - 13-375-16

1/4					
13-374-13	13-374-14	13-374-16	13-375-13	13-375-14	13-375-16
13,5 cm / 5 3/8"	14,5 cm / 5 6/8"	17 cm / 6 6/8"	13 cm / 5 1/8"	14 cm / 5 4/8"	16,5 cm / 6 4/8"

13



1/2

Kocher
 13-384-13 - 13-385-14

1/4			
13-384-13	13-384-14	13-385-13	13-385-14
13 cm / 5 1/8"	14,5 cm / 5 6/8"	13 cm / 5 1/8"	14 cm / 5 4/8"
1:2	1:2	1:2	1:2

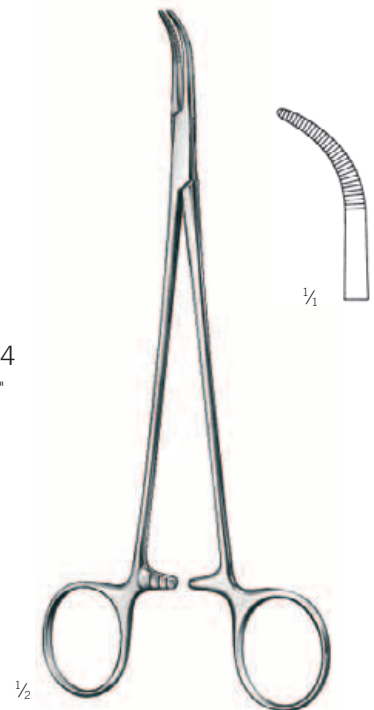

1/2

Mixer-Baby
 13-419-18
 18,5 cm / 7 2/8"

Tuchklemmen

Towel Clamps
 Pinzas de campo
 Pincas à champs
 Pinze fissatele



$\frac{1}{2}$
 Schädel
 13-875-09
 9 cm / 3 $\frac{4}{8}$ "
 scharf
 sharp
 aguda
 aiguë
 acuta



$\frac{1}{2}$
 Jones
 13-881-05 - 13-881-09
 scharf
 sharp
 aguda
 aiguë
 acuta

13-881-05
 5,5 cm / 2 $\frac{1}{8}$ "

13-881-09
 8,5 cm / 3 $\frac{3}{8}$ "



$\frac{1}{2}$
 Backhaus
 13-915-08 - 13-915-15
 scharf
 sharp
 aguda
 aiguë
 acuta

13-915-08
 9 cm / 3 $\frac{4}{8}$ "

13-915-11
 11 cm / 4 $\frac{3}{8}$ "

13-915-13
 13 cm / 5 $\frac{1}{8}$ "

13-915-15
 16 cm / 6 $\frac{2}{8}$ "

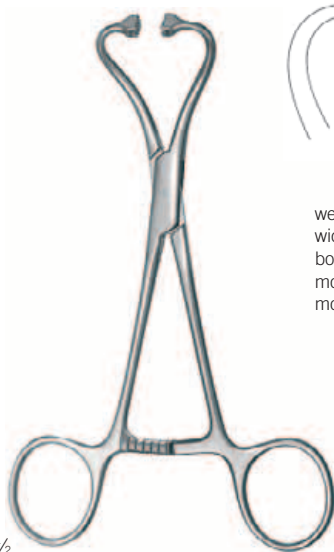

$\frac{1}{2}$
 Peers-Bertram modif.
 13-916-15
 15,5 cm / 6"

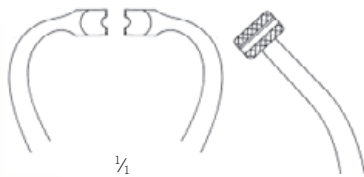

weites Maul zur Schlauchfixierung
 wide jaw for tube fixation
 boca ancha para fijación de tubos
 mors large pour fixation de tube
 morso spalancato per fissare il tubo

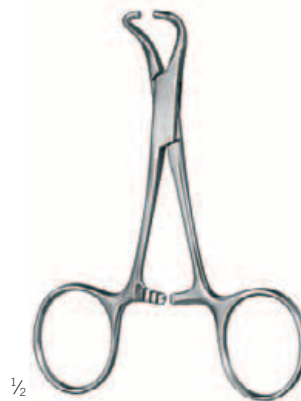

$\frac{1}{2}$
 Tohoku
 13-923-10 - 13-923-13



$\frac{1}{4}$
 13-923-10
 10,5 cm / 4 $\frac{1}{8}$ "

13-923-13
 13,5 cm / 5 $\frac{3}{8}$ "

Tuchklemmen, Arterienklemmen

Towel Clamps, Haemostatic Forceps
 Pinzas de campo, Pinzas hemostáticas
 Pincas à champs, Pincas hémostatiques
 Pinze fissatele, Pinze emostatiche

Arterienklemmen

Haemostatic Forceps
 Pinzas hemostáticas
 Pincas hémostatiques
 Pinze emostatiche

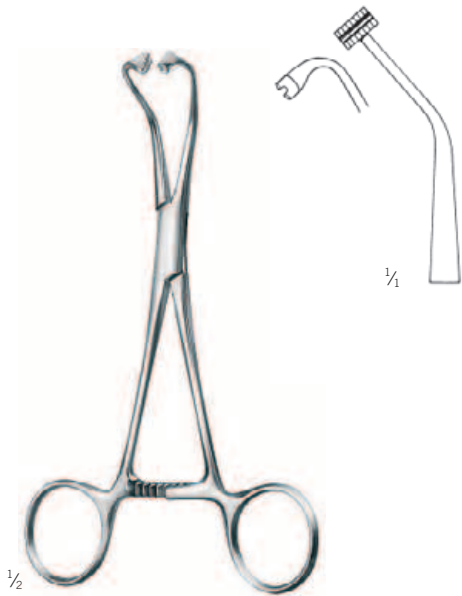

Peers-Bertram
 13-923-14
 14,5 cm / 5 9/16"

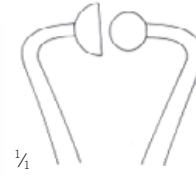

13-924-11
 11,5 cm / 4 5/8"

13-924-14
 14 cm / 5 4/8"

13-924-11 - 13-924-14

für Papierabdeckung
 for paper clothes
 para paños de papel
 pour couverture en papier
 per copertura di carta

Atrauma

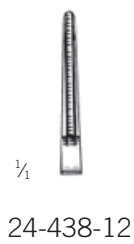

24-438-12



24-439-12

DeBakey-Mosquito
 24-438-12 - 24-439-12
 12,5 cm / 4 7/8"

15

Wundhaken und Abhalter

Hooklets and retractors
Ganchitos y separadores
Crochets et ecarteurs
Divaricatori

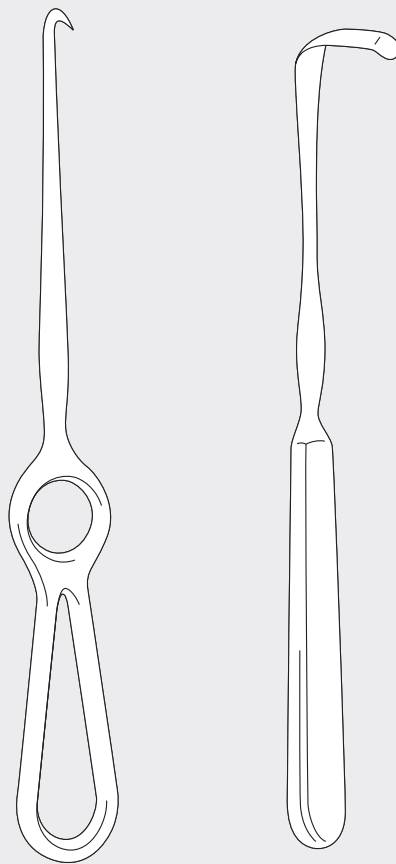

Hauthäkchen, Wundhäkchen

Skin hooks, hooklets

Ganchitos de piel, ganchitos

Crochets pour la peau, crochets

Divaricatori per pelle, divaricatori

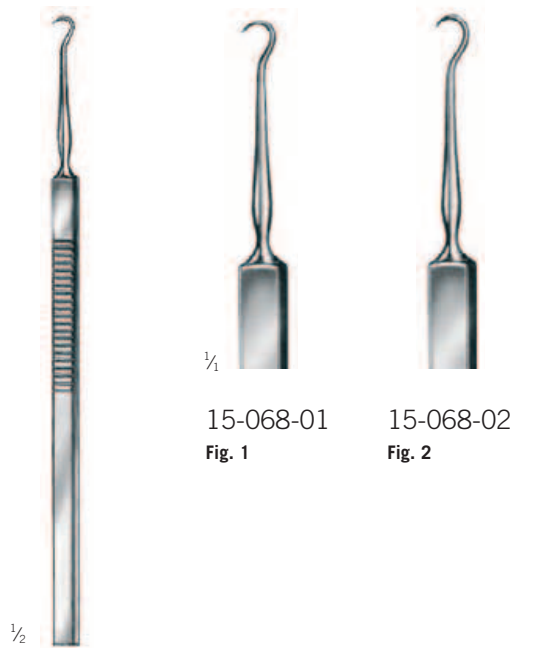

15-068-01
Fig. 1

15-068-02
Fig. 2

15-068-01 - 15-068-02

Fig. 1

16 cm / 6 2/8"

scharf
sharp
aguda
aiguë
acuta

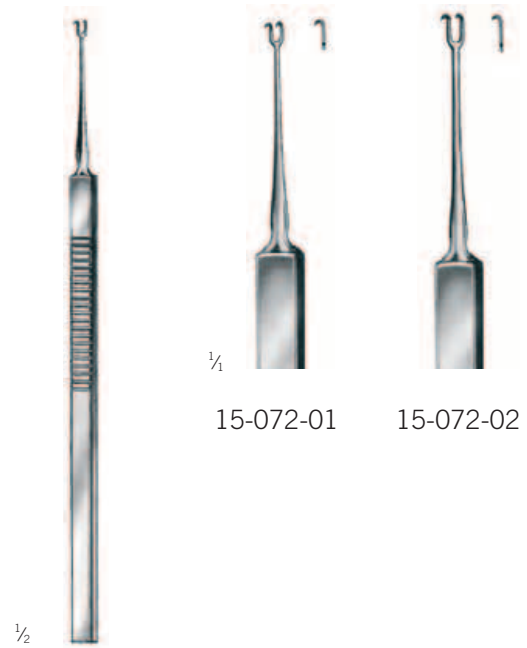

15-072-01

15-072-02

Guthrie

15-072-01 - 15-072-02

15,5 cm / 6 1/8"

scharf
sharp
aguda
aiguë
acuta



15-074-01

15-074-02

15-074-03

15-074-04

15-074-01 - 15-074-04

16,5 cm / 6 4/8"

scharf
sharp
aguda
aiguë
acuta

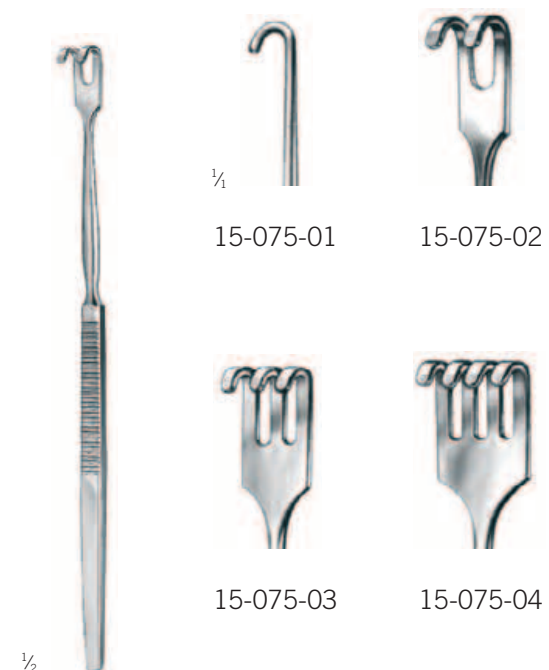

15-075-01

15-075-02

15-075-03

15-075-04

15-075-01 - 15-075-04

16,5 cm / 6 4/8"

stumpf
blunt
romo
mousse
smusso

Sattelhäkchen, Wundhäkchen

Saddle hooks, hooklets

Ganchos en forma de silla, ganchitos

Ecarteurs sous forme de selle, crochets

Divaricatori a forma di sella, divaricatori

Wundhaken und Abhalter

Hooklets and retractors

Ganchitos y separadores

Crochets et ecarteurs

Divaricatori

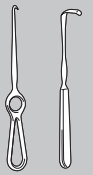

Desmarres
15-091-10 - 15-091-18
16 cm / 6 2/8"



15



Langenbeck Mini
15-095-10 - 15-095-22
16 cm / 6 2/8"

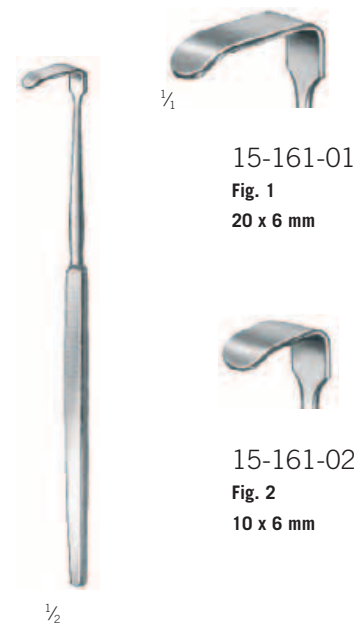

Senn-Green
15-161-01 - 15-161-02
16 cm / 6 2/8"

Wundhaken

Retractors
Separadores
Ecarteurs
Divaricatori



1/2

Kocher-Langenbeck
15-317-01 - 15-317-09
21,5 cm / 8 4/8"

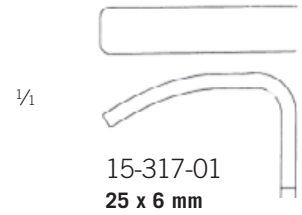

15-317-01
25 x 6 mm

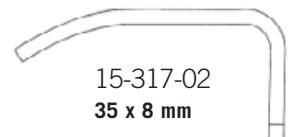

15-317-02
35 x 8 mm

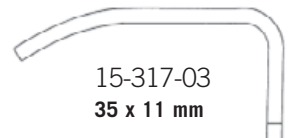

15-317-03
35 x 11 mm

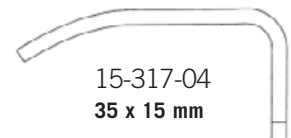

15-317-04
35 x 15 mm

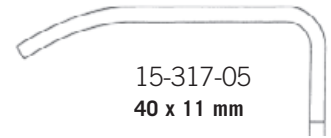

15-317-05
40 x 11 mm

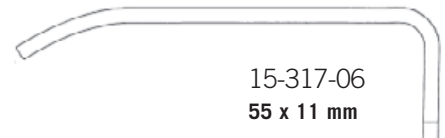

15-317-06
55 x 11 mm



15-317-07
70 x 14 mm



15-317-08
80 x 12 mm



15-317-09
80 x 16 mm

Wundhaken

Retractors
Separadores
Ecarteurs
Divaricatori

Wundhaken und Abhalter

Hooklets and retractors
Ganchitos y separadores
Crochets et ecarteurs
Divaricatori

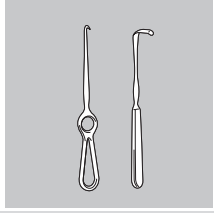

15

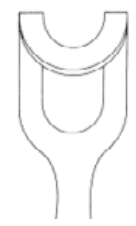
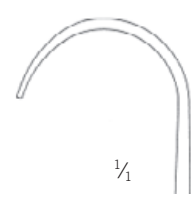
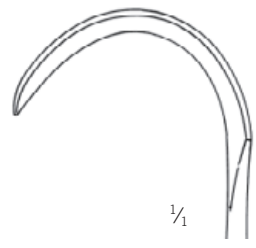
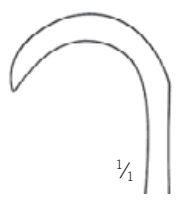

15-361-01
21,5 cm / 8 1/2"
15 x 17 mm

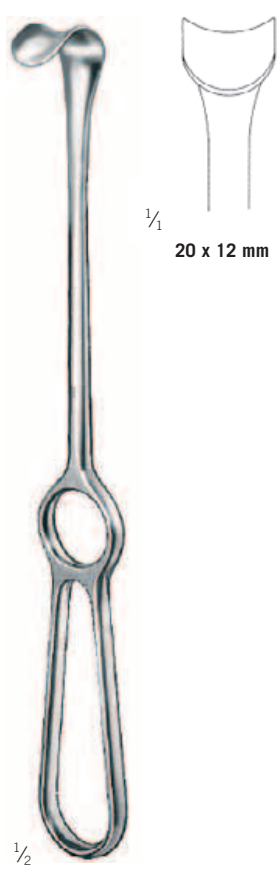

20 x 12 mm

Kocher
15-325-01
21,5 cm / 8 4/8"



15-351-01
22 cm / 8 5/8"
40 x 10 mm



15-351-02
23 cm / 9"
40 x 15 mm

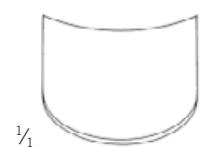

15-351-03
23 cm / 9"
40 x 20 mm

Kocher
15-351-01 - 15-351-03

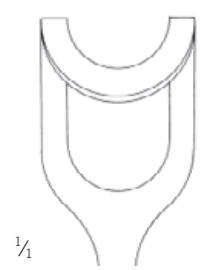

15-361-02
23 cm / 9"
22 x 22 mm

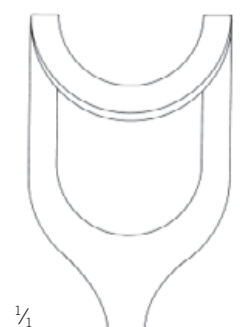

15-361-03
24 cm / 9 4/8"
26 x 31 mm

Middeldorpf
15-361-01 - 15-361-03

Wundhaken

Retractors
Separadores
Ecarteurs
Divaricatori



Fig. 1
15-655-01
14,5 cm / 5 7/8"
22 x 21 mm
27 x 29 mm

Fig. 2
15-655-02
16 cm / 6 2/8"
25 x 26 mm
30 x 38 mm

Fig. 3
15-655-03
17 cm / 6 6/8"
28 x 29 mm
33 x 43 mm

Roux
15-655-00 - 15-655-03

Fig. 1 - 3
15-655-00
17 cm / 6 6/8"
Satz
Set

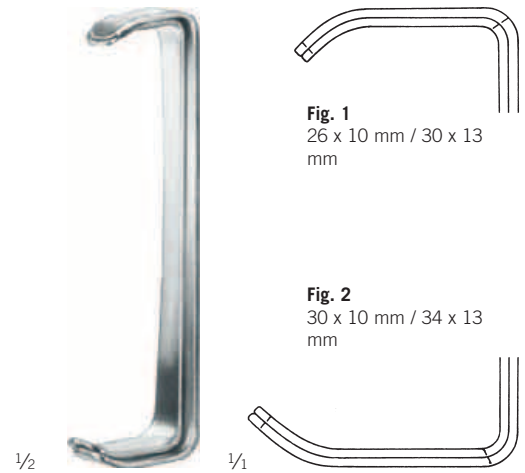

Fig. 1
26 x 10 mm / 30 x 13 mm

Fig. 2
30 x 10 mm / 34 x 13 mm

Farabeuf
15-663-00
12 cm / 4 5/8"

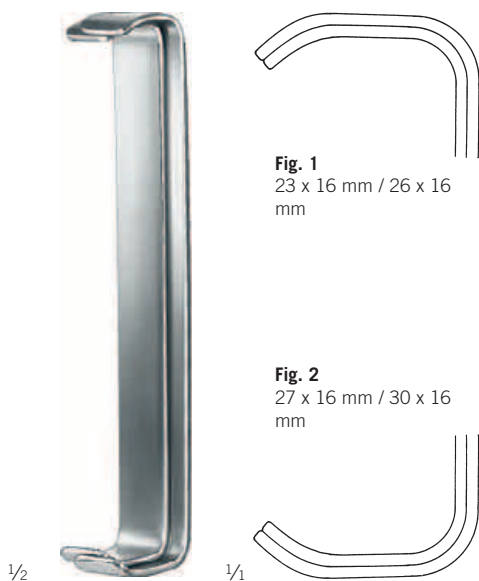
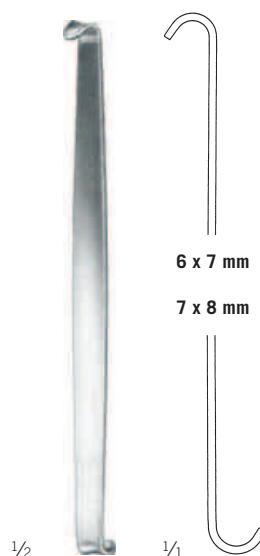

Fig. 1
23 x 16 mm / 26 x 16 mm

Fig. 2
27 x 16 mm / 30 x 16 mm

Farabeuf
15-665-00
15,5 cm / 6 1/8"



6 x 7 mm

7 x 8 mm

Roux-Mini
15-667-06
14,5 cm / 5 5/8"

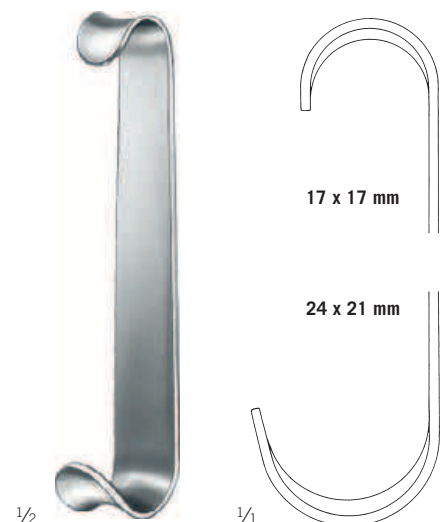

17 x 17 mm

24 x 21 mm

Roux-Baby
15-669-13
12,5 cm / 4 7/8"

Wundhaken

Retractors
Separadores
Ecarteurs
Divaricatori

Wundhaken und Abhalter

Hooklets and retractors
Ganchitos y separadores
Crochets et ecarteurs
Divaricatori

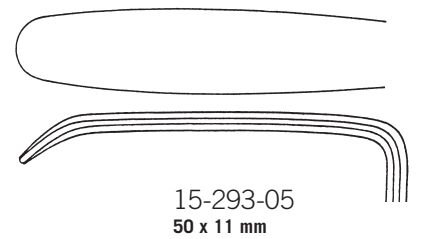
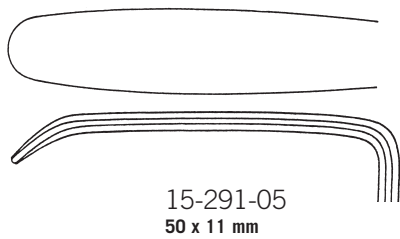
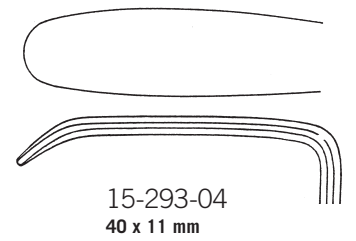
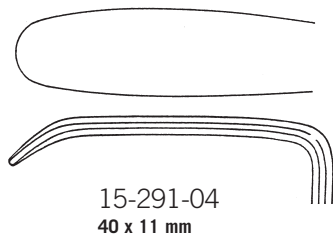
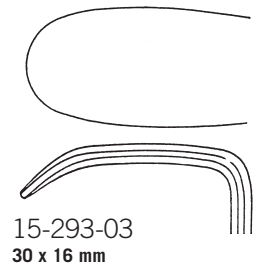
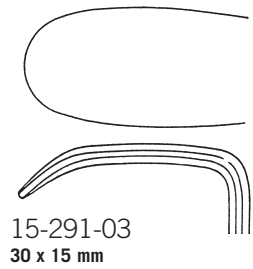
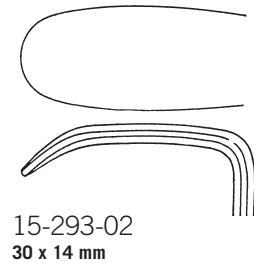
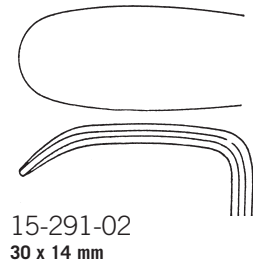
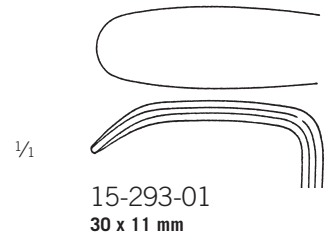
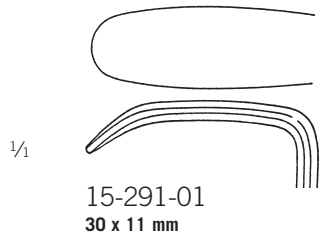
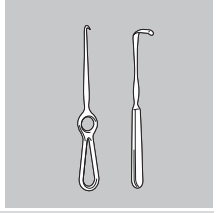

1/2

1/2

Langenbeck
15-291-01 - 15-291-05
22 cm / 8 5/8"

Langenbeck
15-293-01 - 15-293-05
22 cm / 8 5/8"

15

Wundhaken

Retractors
Separadores
Ecarteurs
Divaricatori

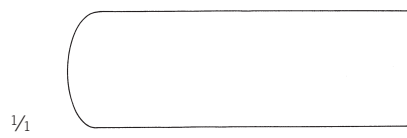

15-561-01
45 x 15 mm

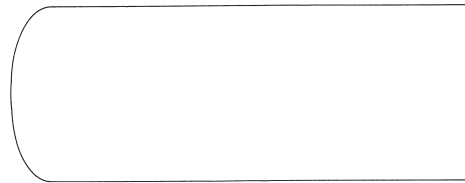

15-561-02
60 x 23 mm

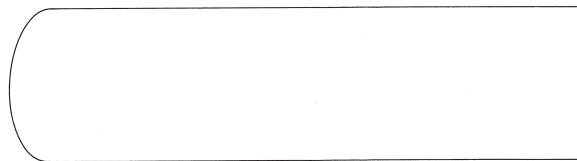

15-561-03
72 x 20 mm



1/2

Sauerbruch
15-561-03

Wundhaken

Retractors
Separadores
Ecarteurs
Divaricatori

Wundhaken und Abhalter

Hooklets and retractors
Ganchitos y separadores
Crochets et ecarteurs
Divaricatori

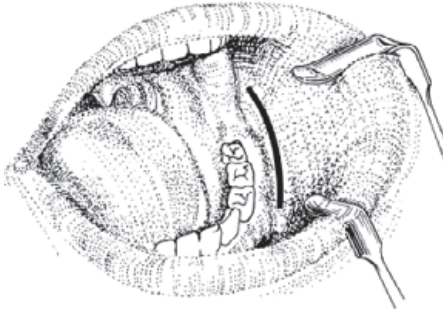
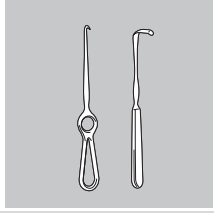

1/4



1/2

Obwegeser
48-101-16 - 48-101-80

aufwärts gebogen
bent upwards
angulado hacia arriba
coudé en haut
angolato in alto



48-101-16
21,5 cm / 8 4/8"
16 x 5 mm



48-101-25
21 cm / 8 2/8"
25 x 7 mm



48-101-35
23 cm / 8"
35 x 10 mm



48-101-42
23 cm / 8"
42 x 10 mm



48-101-55
23,5 cm / 9 2/8"
55 x 13 mm



48-101-70
23,5 cm / 9 2/8"
67 x 15 mm



1/1

48-101-80
24 cm / 9 4/8"
80 x 17 mm

15

Weichteilhaken

Soft Tissue Retractors

Separadores para partes blandas

Ecarteurs pour parties molles

Divaricatori per tessuti molli

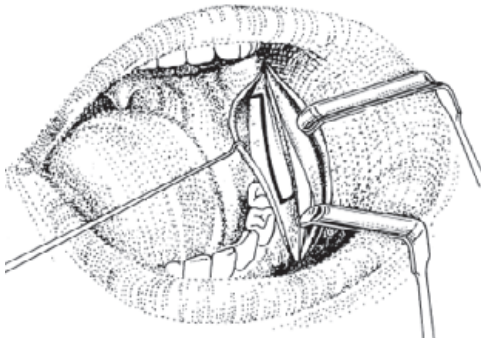

Obwegeser
48-103-16 - 48-103-80

abwärts gebogen
bent downwards
angulado hacia abajo
coudé en bas



48-103-16
21 cm / 8 2/8"
16 x 5 mm



48-103-25
21 cm / 8 2/8"
25 x 7 mm



48-103-35
23 cm / 8"
35 x 10 mm



48-103-42
23 cm / 8"
42 x 10 mm



48-103-55
23,5 cm / 9 2/8"
55 x 12 mm



48-103-70
23,5 cm / 9 2/8"
66 x 15 mm



1/4

48-103-80
23,5 cm / 9 2/8"
80 x 16 mm

Kinnhalter

Chin holder
Separador para mentón
Ecarteur pour menton
Divaricatore per mento

Wundhaken und Abhalter

Hooklets and retractors
Ganchitos y separadores
Crochets et ecarteurs
Divaricatori

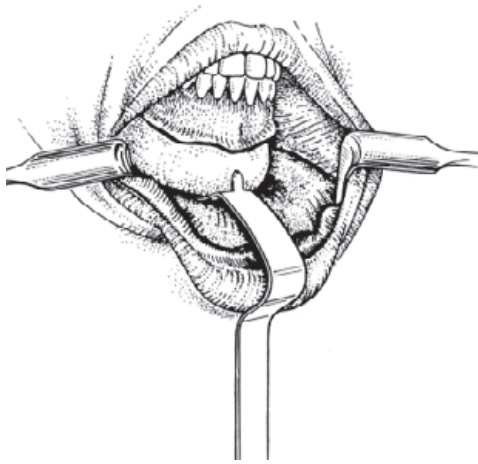
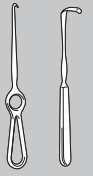

15



$\frac{1}{2}$

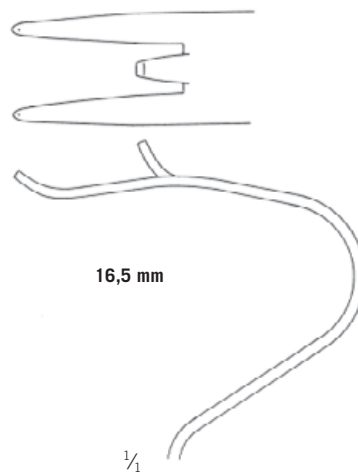

16,5 mm

$\frac{1}{4}$

Obwegeser
48-125-15

16 cm / 6 $\frac{2}{8}$ "

Kinnhalter
Chin holder
Separador para mentón
Ecarteur pour menton
Divaricatore per mento

16

Knopfsonden, Watteträger

Probes, applicators
Sondas, porta algodones
Sondes, porte cotons
Sonde, porta cotoni

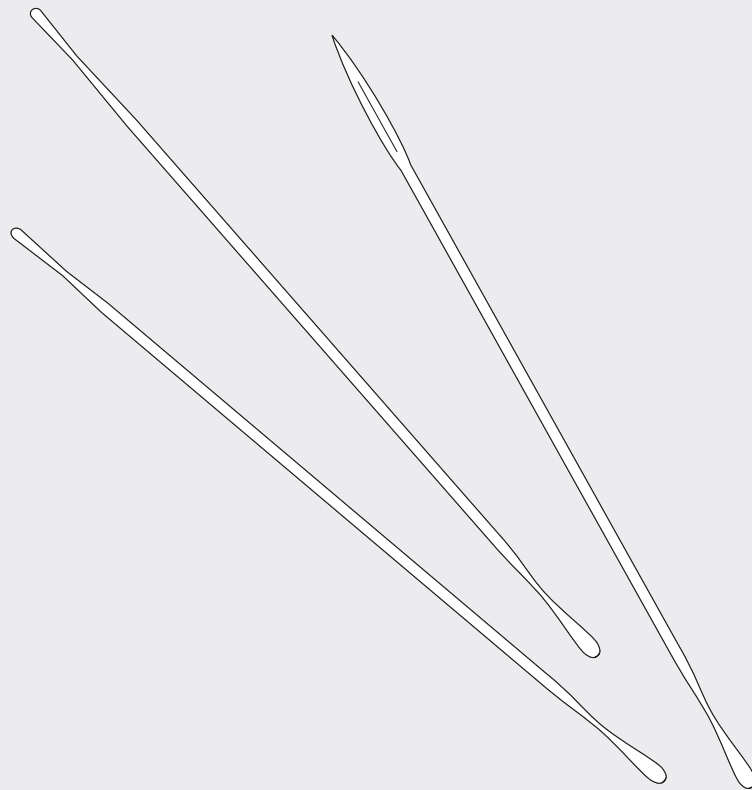

Knopfsonden, Watteträger

Probes, applicators
 Sondas, porta algodones
 Sondes, porte cotons
 Sonde, porta cotoni



16-100-11	11 cm / 4 3/8"	Ø 2,0 mm
16-100-13	13 cm / 5 1/8"	Ø 2,0 mm
16-100-14	14,5 cm / 5 9/8"	Ø 2,0 mm
16-100-16	16 cm / 6 2/8"	Ø 2,0 mm
16-100-18	18 cm / 7 1/8"	Ø 2,0 mm
16-100-20	20 cm / 7 7/8"	Ø 2,0 mm
16-100-25	25 cm / 9 7/8"	Ø 2,0 mm
16-100-30	30 cm / 11 7/8"	Ø 2,0 mm

16-100-11 - 16-100-30

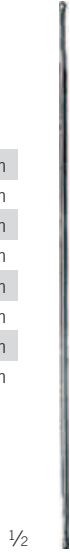

16-102-11	11,5 cm / 4 4/8"	Ø 1,0 mm
16-102-13	13 cm / 5 1/8"	Ø 1,0 mm
16-102-14	14,5 cm / 5 4/8"	Ø 1,0 mm
16-102-16	16 cm / 6 2/8"	Ø 1,0 mm
16-102-18	18 cm / 7 1/8"	Ø 1,0 mm
16-102-20	20 cm / 7 7/8"	Ø 1,0 mm

16-102-11 - 16-102-20

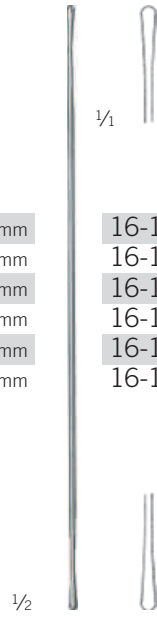

16-103-13	13 cm / 5 1/8"	Ø 1,5 mm
16-103-14	14,5 cm / 5 6/8"	Ø 1,5 mm
16-103-16	16 cm / 6 2/8"	Ø 1,5 mm
16-103-18	18 cm / 7 7/8"	Ø 1,5 mm
16-103-20	20 cm / 7 7/8"	Ø 1,5 mm
16-103-25	25 cm / 9 7/8"	Ø 1,5 mm

16-103-13 - 16-103-25



16-420-12	12 cm / 4 6/8"	Ø 0,9 mm
16-420-14	14 cm / 5 4/8"	Ø 0,9 mm
16-420-16	16 cm / 6 2/8"	Ø 1,1 mm

Farrell
 16-420-12 - 16-420-16

17

Diagnostik

Diagnostics
Diagnóstico
Diagnostic
Diagnostica



Schieblehren

Calipers
Calibres
Pieds à coulisse
Calibri



1/2

Jameson
17-407-01

Einteilung in mm & Inch
graduated in mm and inches
graduado en mm y pulgadas
divisé en millimètres et pouces
diviso in millimetri et pollici



1/2

Townley
17-409-01

11,5 cm / 4 4/8"

Einteilung in mm & Inch
graduated in mm and inches
graduado en mm y pulgadas
divisé en millimètres et pouces
diviso in millimetri et pollici



1/2

17-416-01

23,5 cm / 9 2/8"

Anzeige in mm & Inch, Messbereich bis 150 mm
graduated in mm and inches, measuring range up to 150 mm
graduado en mm y pulgadas, alcance de medición hasta 150 mm
divisé en millimètres et pouces, pour mesurer jusqu'à 150 mm
diviso in millimetri et pollici, per misurare fino a 150 mm

Maßstäbe

Rulers
Reglas
Règles à mesurer
Misuratori

Diagnostik

Diagnostics
Diagnóstico
Diagnostic
Diagnostica

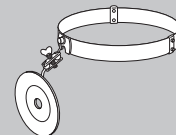

1/2



Einteilung in mm und Zoll
graduated in mm and inches
graduada en mm y pulgadas
divisé en mm et pouces
diviso in millimetri e pollici

	17-418-15	17-418-20	17-418-30	17-418-50
	16,5 cm / 6 4/8"	22 cm / 8 5/8"	31,5 cm / 12 3/8"	52,5 cm / 20 5/8"
Messbereich measuring range up to alcance de medición pour mesurer jusqu'à per misurare fino a	150 mm	200 mm	300 mm	500 mm

17

1/2



Einteilung in mm und Zoll
graduated in mm and inches
graduada en mm y pulgadas
divisé en mm et pouces
diviso in millimetri e pollici

	17-422-15	
	16,5 cm / 6 4/8"	
Messbereich measuring range up to alcance de medición pour mesurer jusqu'à per misurare fino a	150 mm	mit Lochlehre with hole gauge con calibre de agujeros calibre avec trous calibro forato

Kopflupe, Stiellupen

Head loupe, magnifying glasses

Lupa frontal, lupas

Loupe frontale, loupes

Lente frontale, lenti d'ingrandimento



17-610-00

binokular, verstellbarer Stirnreif, Arbeitsabstand bis 40 cm, Vergrößerung 1,8 x

binocular, adjustable head band, free working distance up to 40 cm approx., magnifying power 1,8 x

binocular, cinta frontal regulable, hasta distancia de trabajo aprox. 40 cm, aumento 1,8 x

binoculaire, bandeau frontal réglable, distance d'observation jusqu'à 40 cm, agrandissement 1,8 x

binoculare, fascia frontale regolabile, distanza di osservazione fino a 40 cm, ingrandimento 1,8 x

17-610-01

Stirnreif

Head Band

Casco frontal

Bandeau frontal

Fascia frontale



17-610-00



1/2

17-625-50

Ø 50 mm

bi-konvex

Metallgriff, Vergrößerung 2,5 x

bi-convex

metal handle, magnifying power 2,5 x

bi-convex

mango metálico, aumento 2,5 x

bi-convexe

à monture en métal, agrandissement 2,5 x

bi-convesso

manico metallico, ingrandimento 2,5 x



1/2

17-627-75

Ø 75 mm

bi-konvex

Kunststoffgriff, Vergrößerung 2,5 x

bi-convex

plastic handle, magnifying power 2,5 x

bi-convex

mango plástico, aumento 2,5 x

bi-convexe

à monture en matière plastique, agrandissement 2 x

bi-convesso

manico in plastica, ingrandimento 2,5 x

Stirnlupen, Rahmen für Linsen

Head Loupes, Frame for Lenses

Lupas frontales, Cuadro con lentes

Loupes frontales, Cadres à deux lentilles

Lenti d'ingrandimento frontale, Montatura metallica

Diagnostik

Diagnostics

Diagnóstico

Diagnostic

Diagnostica

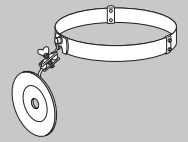

Berger, Mod. Martin 17-640-01

binokular
auswechselbare Linsen, Metallstirnband
Vergrößerung 2,5 x

binocular
exchangeable lenses, metal head band
magnifying power 2,5 x

binocular
lentes intercambiables, cinta frontal metálica
aumento 2,5 x

binoculaire
lentilles interchangeables, bandeau frontal en métal
agrandissement 2,5 x

binoculare
lenti intercambiabili, fascia frontale metallica
ingrandimento 2,5 x

Berger 17-640-02

binokular
auswechselbare Linsen, aufklappbar
Vergrößerung 2,5 x

binocular
exchangeable lenses, hinged housing
magnifying power 2,5 x

binocular
lentes intercambiables, ajustable
aumento 2,5 x

binoculaire
lentilles interchangeables, escamotable,
agrandissement 2,5 x

binoculare
lenti intercambiabili, regolabili
ingrandimento 2,5 x

17



Berger

	17-645-15	17-645-20	17-645-25	17-645-30
binokular, Arbeitsabstand binocular, free working distance binocular, distancia de trabajo binoculaire, distance d'observation binoculare, distanza di osservazione	220 mm = 4 Diop.	170 mm = 5,5 Diop.	130 mm = 7 Diop.	100 mm = 8,5 Diop.
Vergrößerung magnifying power aumento agrandissement ingrandimento	1,5 x	2 x	2,5 x	3 x
	17-640-01 + 17-640-02	17-640-01 + 17-640-02	17-640-01 + 17-640-02	17-640-01 + 17-640-02

Messzirkel

Calipers
Compases
Compas
Compassi

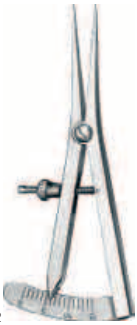

1/2

Castroviejo
35-133-06

8 cm / 3 1/8"

Messbereich
effective range
alcance eficaz
série effectif
rango effective
0-15 mm



1/2

Castroviejo
35-133-07

8 cm / 3 1/8"

Messbereich
effective range
alcance eficaz
série effectif
rango effective
0-20 mm



1/2

Castroviejo
35-133-09

8 cm / 3 1/8"

Messbereich
effective range
alcance eficaz
série effectif
rango effective
0-20 mm



1/2

Castroviejo-Epker
35-134-09

9 cm / 3 4/8"

Messbereich
effective range
alcance eficaz
série effectif
rango effective
0-40 mm



1/2

Castroviejo-Epker
35-134-18

18 cm / 7 1/8"

Messbereich
effective range
alcance eficaz
série effectif
rango effective
0-40 mm

OP-Leuchten, Untersuchungsleuchten

Operating theatre lights, examination lights
Lámparas de quirófano, lámparas de examinación
Lampes opératoires, lampes d'examen
Lampade scialitiche, lampade diagnostiche

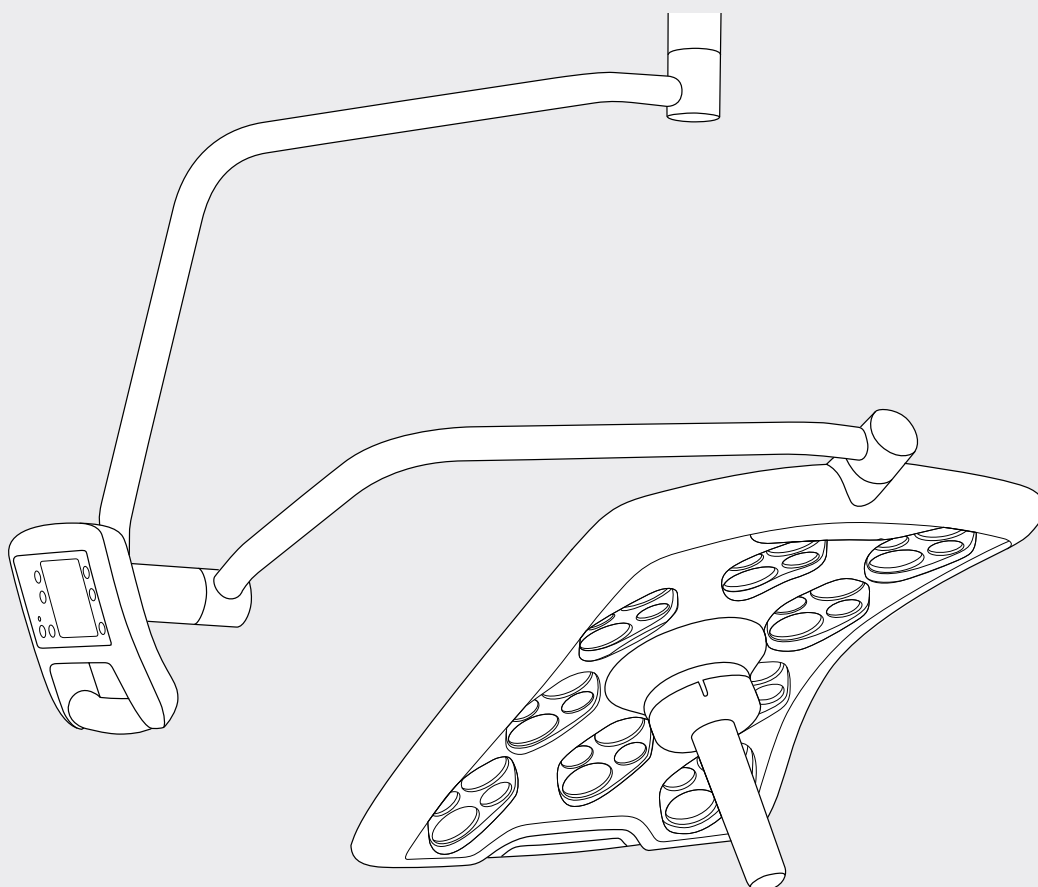

Untersuchungsleuchten ML 101 / ML 201+

Examination lights ML 101 / ML 201+

Lámparas de examinación ML 101 / ML 201+

Lampes d'examen ML 101 / ML 201+

Lampade diagnostiche ML 101 / ML 201+



86-013-10

ML 201+ Stativleuchte
ML 201+ Mobile light
ML 201+ Lámpara móvil
ML 201+ Eclairage mobile
ML 201+ Lampada su stativo



86-010-10

ML 101 Stativleuchte
ML 101 Mobile light
ML 101 Lámpara móvil
ML 101 Eclairage mobile
ML 101 Lampada su stativo

ML 101/ML 201+ Untersuchungsleuchten

In Klinik und Arztpraxis werden an Untersuchungsleuchten hohe Anforderungen gestellt. Die KLS-Martin-Untersuchungs- und Krankenbettleuchten ML 101 und ML 201+ wurden speziell für diesen Einsatz entwickelt.

Diese Leuchten tragen dazu bei, die täglichen Kontrollen im medizinischen Bereich für Ärzte und Pflegepersonal angenehmer zu gestalten. Ob als mobile Leuchte mit fahrbarem Fünffuß oder mit Adapter für die Normschiene (ML 101) – KLS-Martin-Untersuchungsleuchten sind in jeder Situation einsetzbar.

- **Modernste Lichttechnik**
- **Ergonomisches Design**
- **Leicht einstellbar**
- **Vielfältige Anbringungs- und Einsatzmöglichkeiten**

ML 101/ML 201+ Examination Lights

Also small lights used in hospitals and medical practices have to meet special requirements. The KLS Martin examination lights ML 101 and ML 201+ have been specially designed for this purpose.

These lights help to make daily examinations easier and more convenient for the medical staff. As mobile light with five castors or mounted with special adapter to a norm rail (ML 101) – the KLS Martin examination lights are a useful tool in every situation.

- **Modern Light Technology**
- **Ergonomic Design**
- **Easily adjustable**
- **Different Possibilities of Positioning and Use**

ML 101/ML 201+ Lámparas de examinación

En las clínicas y los consultorios médicos se ponen altas exigencias a las lámparas de exploración. Las lámparas de examinación ML 101 y ML 201+ de KLS Martin fueron especialmente desarrolladas para este tipo de aplicación.

Estas lámparas contribuyen a facilitar los reconocimientos diarios en el sector sanitario y proporcionan mayor confort a médicos y personal sanitario. Ya sea como lámpara móvil con cinco rodillos o montadas con adaptador especial en una guía normalizada (ML 101), las lámparas de examinación de KLS Martin son una herramienta útil para cualquier situación.

- **Técnica moderna de alumbrado**
- **Diseño ergonómico**
- **Fácilmente ajustable**
- **Posibilidades diversas de posicionamiento y aplicación**

NEU ML 201+ mit zusätzlichem Leuchtmittel für Lese- bzw. Reservelicht

NEU ML 201+ with additional light bulb for reading or backup light mode

NEU ML 201+ con medio de iluminación adicional como lámpara de lectura o luz de reserva

Technische Daten	ML 101	ML 201+
Halogenlampe	12V / 35 W	12V / 35 W / IRC
Beleuchtungsstärke (Abstand 500 mm)	27.000 Lux	40.000 Lux 1.700 Lux*
Farbtemperatur	3.000 K	3.200 K
Durchmesser Lichtfeld	96 mm	96 mm
Brenndauer Halogenlampe	3.000 h	2.000 h
Farbe	RAL 9002	RAL 9002
Elektrik nach	VDE / IEC	VDE / IEC
Farbwiedergabe-Index	96	96

Technical Data	ML 101	ML 201+
Halogen bulb	12V / 35 W	12V / 35 W / IRC
Light output (distance 500 mm)	27,000 Lux	40,000 Lux 1,700 Lux*
Color temperature	3,000 K	3,200 K
Diameter of illuminated field	96 mm	96 mm
Lifetime of the bulb	3,000 h	2,000 h
Color	RAL 9002	RAL 9002
Components and wiring in acc. to	VDE / IEC	VDE / IEC
Color rendering index	96	96

Características técnicas	ML 101	ML 201+
Bombilla halógena	12V / 35 W	12V / 35 W / IRC
Iluminancia (distancia de 500 mm)	27.000 lux	40.000 lux 1.700 lux*
Temperatura del color	3.000 K	3.200 K
Diámetro del campo de luz	96 mm	96 mm
Horas de alumbrado de la bombilla halógena	3.000 h	2.000 h
Color	RAL 9002	RAL 9002
Sistema eléctrico conforme a	VDE/IEC	VDE/IEC
Índice de reproducción cromática	96	96

* Lese- bzw. Reservelicht

* Reading or backup light mode

* Luz de lectura o de reserva

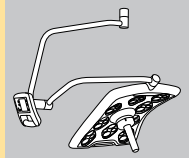

86-010-20

ML 101 für Normschiene
 ML 101 for rail-system
 ML 101 para guía normalizada
 ML 101 pour rail standard
 ML 101 per guida standard



86-013-20

ML 201+ Wandleuchte
 ML 201+ Wall-mounted light
 ML 201+ Lámpara mural
 ML 201+ Eclairage mural
 ML 201+ Lampada a parete

ML 101/ML 201+ Lampes d'examen

Qu'elles soient utilisées en milieu hospitalier ou dans des cabinets médicaux, les lampes d'examen doivent satisfaire à des exigences sévères. Les lampes d'examen et pour lits de malades ML 101 et ML 201+ de KLS Martin ont été spécialement conçus pour ces utilisations.

Ces éclairages contribuent à faciliter les contrôles médicaux quotidiens pour les médecins et le personnel soignant. Eclairages mobiles avec pied à roulettes à cinq branches ou avec adaptateur pour le rail standard (ML 101) – les lampes d'examen KLS Martin peuvent être utilisées dans toutes les situations.

- **Technique d'éclairage extrêmement moderne**
- **Design ergonomique**
- **Réglage aisé**
- **Multiples possibilités de fixation et d'utilisation**



ML 201+ avec lampe supplémentaire pour éclairage de lecture et/ou de réserve

ML 101/ML 201+ Lampade diagnostiche

In clinica e negli ambulatori medici vengono posti requisiti elevati per quanto concerne le lampade diagnostiche. Le lampade diagnostiche e le lampade per letti ospedalieri ML 101 e ML 201+ di KLS Martin sono state specialmente sviluppate per questo tipo di impiego.

Esse contribuiscono a rendere più piacevoli i controlli quotidiani nel settore medico per medici e personale paramedico. Sia come lampada mobile con cinquepiede a rotelle, sia nella versione con adattatore per la guida standard (ML 101), le lampade diagnostiche di KLS Martin sono utilizzabili in qualsiasi situazione.

- **Tecnica di illuminazione modernissima**
- **Design ergonomico**
- **Di facile impostazione**
- **Molteplici possibilità di posizionamento e d'impiego**



ML 201+ con sorgente luminosa supplementare come luce di lettura e come luce di riserva

Caractéristiques techniques	ML 101	ML 201+
Lampe halogène	12 V / 35 W	12 V / 35 W / IRC
Eclairage (distance 500 mm)	27.000 lux	40.000 lux 1.700 lux*
Température de couleur	3.000 K	3.200 K
Diamètre du champ lumineux	96 mm	96 mm
Durée de vie lampe halogène	3.000 h	2.000 h
Coloris	RAL 9002	RAL 9002
Composants et câblage conformes à	VDE / IEC	VDE / IEC
Indice de rendu des couleurs	96	96

* Eclairage de lecture et/ou de réserve

Dati tecnici	ML 101	ML 201+
Lampada alogena	12V/35 W	12V/35 W/IRC
Intensità di illuminazione (distanza 500 mm)	27.000 Lux	40.000 Lux 1.700 Lux*
Temperatura colore	3.000 K	3.200 K
Diametro del campo luminoso	96 mm	96 mm
Durata utile della lampadina alogena	3.000 h	2.000 h
Colore	RAL 9002	RAL 9002
Componenti elettrici secondo	VDE/IEC	VDE/IEC
Indice di resa del colore	96	96

* Luce di lettura e di riserva

Untersuchungsleuchten ML 301

Examination lights ML 301
Lámparas de examinación ML 301
Lampes d'examen ML 301
Lampade diagnostiche ML 301



86-031-10

ML 301S Stativleuchte
ML 301S Mobile light
ML 301S Lámpara móvil
ML 301S Eclairage mobile
ML 301S Lampada su stativo



86-031-00

ML 301D Deckenleuchte
ML 301D Ceiling-mounted light
ML 301D Lámpara de techo
ML 301D Eclairage plafonnier
ML 301D Lampada a soffitto

KLS Martin ML 301 Blendfreies Licht als ergonomischer Faktor für medizinische Untersuchungen

Die Untersuchungsleuchte KLS Martin ML 301 wird den Anforderungen bei medizinischen Untersuchungen durch das Zweifachreflektor-Prinzip gerecht. Durch die gezielte Lichtlenkung des Kegelreflektors (Grafik) wird eine optimale Ausnutzung des Hauptreflektors erreicht. Dadurch verfügt die KLS Martin ML 301 über die beste Lichtqualität aller am Markt befindlichen Leuchten. Des Weiteren bietet die hocheffiziente Licht-Wärme-Trennung optimale Farb- und Kaltlichteigenschaften.

Die Untersuchungsleuchte KLS Martin ML 301 ist durch die hervorragende Lichtleistung von 40.000 Lux für eine sichere Diagnostik bestens geeignet. Außerdem ist die KLS Martin ML 301 die ideale Ergänzung zu der bestehenden KLS-Martin-Operationsleuchten-Familie.

Martin ML 301 Non glare light as an ergonomic factor in medical examinations

The examination light KLS Martin ML 301 satisfies the requirements met in medical examinations by making use of the dual-reflector principle. Thanks to the targeted light directing provided by the cone reflector (see illustration), optimum utilization of the main reflector is achieved. The KLS Martin ML 301 therefore provides the best light quality of all lights available on the market. In addition, the highly efficient light-heat separation means optimal color and cold-light characteristics.

Furthermore, its outstanding light output of 40,000 lux certainly makes the KLS Martin ML 301 an excellent tool for safe diagnostics. And last but not least, the KLS Martin ML 301 examination light is an ideal complement to the existing family of KLS Martin operating lights.

Technische Daten	ML 301
Elektrische Anschlussleistung	230 V, 50-60 Hz
Farbtemperatur	4.200 K
Beleuchtungsstärke bei 1 m Abstand	50.000 lux
Lichtfelddurchmesser	180 mm
Farbwiedergabeindex Ra (1-8)	96
Lichtausbeute (Photometrischer Strahlungsäquivalent)	290 lm/W
Arbeitsbereich	27 - 173 cm
Lampennennleistung	12 V / 50 W
Lampenlebensdauer	2.000 Std.
Farbgebung	RAL 9002
Elektrik	nach VDE/IEC
Schwenkradius	
- Deckenleuchte	1.770 mm
- Wandleuchte	1.860 mm
- Stativleuchte	970 mm
Höhenverstellung	1.290 mm
Gewichte	
- Deckenleuchte	10 kg
- Wandleuchte	9 kg
- Stativleuchte	20 kg
CE-Kennzeichnung konform mit 93/42/EWG	

Technical Data	ML 301
Power supply data	230 V, 50-60 Hz
Color temperature	4,200 K
Light intensity at 1 m distance	50,000 lux
Light field diameter	180 mm
Color rendering index Ra (1-8)	96
Luminous efficacy in the light field	290 lm/W
Working space	27 - 173 cm
Power consumption (bulb)	12 V / 50 W
Life time of the bulb	2,000 h
Color	RAL 9002
Components and wiring in acc. with	VDE/IEC
Sswivel radius	
- ceiling-mounted light	1,770 mm
- wall-mounted light	1,860 mm
- mobile light	970 mm
Vertical adjustment	1,290 mm
Weights	
- ceiling-mounted light	10 kg
- wall-mounted light	9 kg
- mobile light	20 kg
CE marking conform with 93/42/EEC	

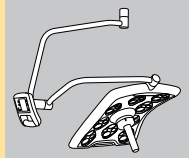

86-031-20

ML 301W Wandleuchte
 ML 301W Wall-mounted light
 ML 301W Lámpara mural
 ML 301W Eclairage mural
 ML 301W Lampada a parete

ML 301 de KLS Martin
 Luz antideslumbrante como factor ergonómico para reconocimientos médicos

La lámpara de examinación ML 301 de KLS Martin cumple con los requisitos necesarios en los reconocimientos médicos gracias al principio de reflector doble. Mediante el direccionamiento específico de la luz con el reflector cónico (figura) se consigue un aprovechamiento óptimo del reflector principal. Ello hace que la ML 301 de KLS Martin disponga de la mejor calidad de luz de todas las lámparas disponibles en el mercado. Además, la separación altamente eficiente entre luz y calor ofrece características óptimas de color y luz fría.

La excelente potencia luminosa de 40.000 lux convierte a la lámpara de examinación ML 301 de KLS Martin en una herramienta sobresaliente para diagnósticos seguros. Además, la ML 301 de KLS Martin es el complemento ideal a la familia de lámparas de quirófano de KLS Martin ya existente.

KLS Martin ML 301
 La lumière antiéblouissante comme facteur ergonomique pour les examens médicaux

La lampe d'examen ML 301 de KLS Martin satisfait aux exigences pour les examens médicaux grâce au principe du réflecteur double. L'orientation ciblée de la lumière (voir graphique) permet une exploitation optimale du réflecteur principal. De ce fait, la lampe d'examen ML 301 de KLS Martin offre la meilleure qualité de lumière du marché. De plus, la séparation extrêmement efficace de la lumière et de la chaleur est synonyme de propriétés optimales en termes de couleur et de lumière froide.

De par son excellent rendement lumineux de 40.000 lux, la lampe d'examen ML 301 de KLS Martin permet d'effectuer un diagnostic très fiable. La lampe d'examen ML 301 de KLS Martin est en outre le complément idéal de la famille d'éclairages opératoires KLS Martin.

ML 301 di KLS Martin
 Luce non abbagliante come fattore ergonomico per analisi mediche

La lampada diagnostica ML 301 di KLS Martin soddisfa i requisiti delle analisi mediche grazie al principio del doppio riflettore. Tramite la focalizzazione mirata della luce del riflettore conico (grafica) si ottiene lo sfruttamento ottimale del riflettore principale. In questo modo la lampada ML 301 di KLS Martin dispone della migliore qualità di luce in assoluto rispetto a tutte le lampade esistenti sul mercato. Inoltre la separazione altamente efficiente tra luce e calore offre proprietà ottimali di luce cromatica e fredda.

La lampada diagnostica ML 301 di KLS Martin è perfettamente adatta a garantire una diagnosi sicura grazie all'eccellente resa luminosa di 40.000 Lux. Essa costituisce inoltre l'integrazione ideale alla gamma di lampade scialitiche di KLS Martin già esistenti.

Características técnicas	ML 301
Potencia de conexión eléctrica	230 V, 50-60 Hz
Temperatura del color	4.200 K
Iluminancia a 1 m de distancia	50.000 lux
Diámetro del campo de luz	180 mm
Índice de reproducción cromática Ra (1-8)	96
Rendimiento lumínico (eficacia luminosa)	290 lm/W
Rango operativo	27 - 173 cm
Potencia nominal de la bombilla	12 V/50 W
Vida útil de la bombilla	2.000 h
Color	RAL 9002
Sistema eléctrico conforme a	VDE/IEC
Radio de giro	
- Lámpara de techo	1.770 mm
- Lámpara mural	1.860 mm
- Lámpara móvil	970 mm
Ajuste en altura	1.290 mm
Pesos	
- Lámpara de techo	10 kg
- Lámpara mural	9 kg
- Lámpara móvil	20 kg
Marchamo CE de conformidad con la directiva 93/42/CEE	

Caractéristiques techniques	ML 301
Puissance de raccordement électrique	230 V, 50-60 Hz
Température de couleur	4.200 K
Eclairage à 1 m de distance	50.000 lux
Diamètre du champ lumineux	180 mm
Indice de rendu des couleurs Ra (1-8)	96
Efficacité lumineuse du rayonnement	290 lm/W
Plage de travail	27 - 173 cm
Puissance nominale de la lampe	12 V / 50 W
Durée de vie de la lampe	2.000 h
Coloris	RAL 9002
Composants et câblage conformes à	VDE/IEC
Rayon de pivotement	
- Eclairage plafonnier	1.770 mm
- Eclairage mural	1.860 mm
- Eclairage mobile	970 mm
Réglage en hauteur	1.290 mm
Poids	
- Eclairage plafonnier	10 kg
- Eclairage mural	9 kg
- Eclairage mobile	20 kg
Label CE conformément à 93/42/CEE	

Dati tecnici	ML 301
Potenza elettrica di allacciamento	230 V, 50-60 Hz
Temperatura colore	4.200 K
Intensità di illuminazione a distanza di 1 m	50.000 Lux
Diámetro del campo luminoso	180 mm
Indice di resa del colore Ra (1-8)	96
Rendimento luminoso (equivalente di radiazione fotometrico)	290 lm/W
Campo di lavoro	27-173 cm
Potenza nominale lampada	12 V/50 W
Vita utile della lampada	2.000 ore
Colorazione	RAL 9002
Componenti elettrici secondo	VDE/IEC
Raggio di rotazione	
- lampada a soffitto	1.770 mm
- lampada a parete	1.860 mm
- lampada su stativo	970 mm
Regolazione in altezza	1.290 mm
Pesi	
- lampada a soffitto	10 kg
- lampada a parete	9 kg
- lampada su stativo	20 kg
Contrassegno CE conforme a 93/42/CEE	

*Entdecken Sie weitere Produktgruppen von KLS Martin
Explore other product groups of KLS Martin
Descubra más grupos de productos de KLS Martin
Découvrez les autres groupes de produits de KLS Martin
Scopri di più gruppi di prodotti di KLS Martin*



Hell soll es sein, aber nicht warm. Konturieren, ohne Schatten zu werfen. Fokussieren einerseits, Objekte umfließen andererseits. Die Anforderungen an die optimale OP-Leuchte sind ebenso anspruchsvoll wie widersprüchlich. Um sie zu erfüllen, braucht man ein Höchstmaß an Know-how und langjährige Erfahrung. Mit den OP-Leuchten marLux® hat KLS Martin auf Basis modernster Gasentladungstechnologie Maßstäbe gesetzt, die den höchsten Anforderungen gerecht werden.

marLux® –

Licht der nächsten Generation

GB

marLux® – The next generation of lighting

We want good light but without the heat. Contours without shadows. Focussing on the one hand, surrounding objects with light on the other. The requirements regarding the best possible operating lights are as demanding as they are contradictory. Satisfying them requires a maximum level of know-how and extensive experience. The marLux® operating lights based on the most up-to-date gas discharge technology have enabled KLS Martin to set standards to meet the most stringent of requirements.

ES

marLux® – La luz de la generación futura

El espacio debe iluminarse, no calentarse; deben distinguirse bien los contornos, sin proyectar sombras; por un lado, ha de disponerse de buenos enfoques, por otro, la luz debe envolver bien a los objetos. Los requisitos que debe cumplir una lámpara de quirófano para resultar óptima son tan exigentes como contradictorios. Así pues, para poder cumplirlos se necesita un nivel máximo de conocimientos prácticos especializados y largos años de experiencia. Con las lámparas de quirófano marLux® y partiendo de la más moderna tecnología de descarga gaseosa, KLS Martin ha marcado unas pautas que cumplen las más altas exigencias.

F

marLux® – L'éclairage de la prochaine génération

La lumière doit être claire, sans pour autant être chaude. Contourer, sans projeter d'ombres. Focaliser des objets d'une part et les contourner d'autre part. Les exigences requises pour des lampes opératoires optimales sont très élevées, tout en étant contradictoires. Un savoir-faire des plus complets et de nombreuses années d'expérience sont nécessaires afin de pouvoir y répondre. Avec les lampes opératoires marLux®, KLS Martin a constitué une nouvelle référence, sur la base d'une technologie des plus modernes en matière de décharge électrique dans un gaz, référence qui répond aux exigences les plus élevées.

I

marLux® – Luce di ultima generazione

Deve essere chiara, ma non calda; definire i contorni senza creare ombre, mettere a fuoco gli oggetti ma anche avvolgerli di luce. Le luci destinate alle sale operatorie devono soddisfare requisiti stringenti e, talvolta, anche contrastanti tra loro. Per ottenere simili risultati occorrono conoscenze approfondite ed esperienza di lunga data. Con le luci per sale operatorie marLux® KLS Martin ha definito, basandosi sulla più recente tecnologia a scarica di gas, criteri in grado di soddisfare anche i più esigenti!

OP-Leuchten marLux®

Operating theatre lights marLux®

Lámparas de quirófano marLux®

Lampes opératoires marLux®

Lampade scialitiche marLux®

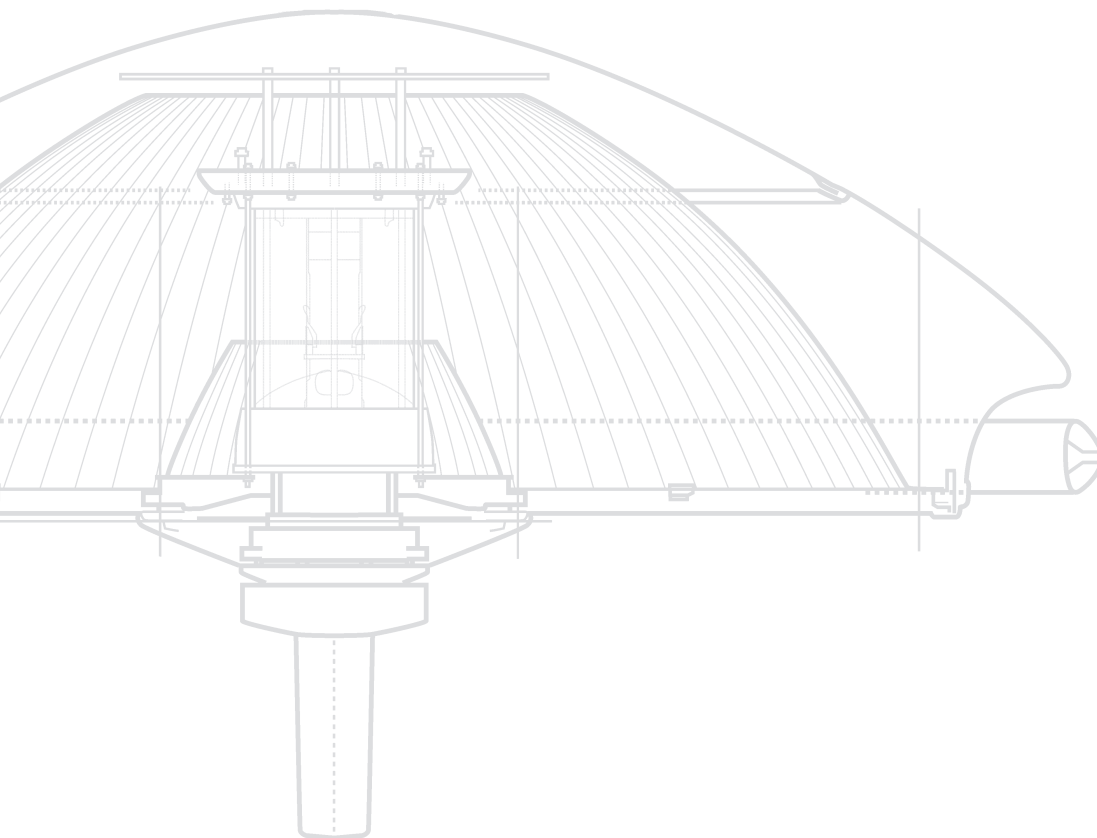

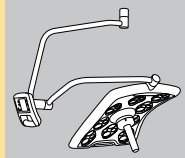

**Die Einaugenleuchte.
 Mit Mittenreflektor.**

Mit marLux® hat KLS Martin der klassischen Einaugenleuchte eine völlig neue Dimension verliehen. Der polysphärische Monoreflektor hat einen weiteren zuschaltbaren Mittenreflektor erhalten. Das bedeutet:

- Insgesamt 540 Reflektoren in computerberechneter Anordnung, die das Licht exakt auf das OP-Feld lenken.
- Gleichmäßiger vertikaler Lichttubus mit homogener Lichtverteilung (siehe Bild rechts).
- Kein Nachfokussieren bei Abstandsveränderungen oder Patientenumlagerungen.
- Schattenfreie Ausleuchtung – das Licht „umfließt“ die Operateure.

**The monoreflector.
 With central reflector.**

With marLux®, KLS Martin has brought a totally new dimension to the classical monoreflector lighting concept. The polyspherical monoreflector incorporates a central reflector that can be switched on and off as needed. This means:

- Altogether 540 reflectors optimally arranged on the basis of computer calculations, channeling the light exactly to the surgical field – the place where it is actually needed.
- Uniform, vertical light tube with absolutely homogeneous light distribution (see picture on the right).
- No refocusing required after light adjustments or patient repositioning.
- Shadowless illumination – the light is directed around the surgeon.

Technische Daten	H5 PLUS	H5
Max. Beleuchtungsstärke in 1 m Abstand (in Lux)	130.000	85.000
Lichtfelddurchmesser d10 in cm	16 – 26	16 – 24
Farbtemperatur in Kelvin (K)	4.300	4.300
Farbwiedergabeindex Ra	93	93
Photometrisches Strahlungsäquivalent in Lumen/Watt (lm/W)	285	285
Strahlungsdichte = Bestrahlungs-/ Beleuchtungsstärke in mW/m ² x lx	3,5	3,5
Arbeitsbereich ohne Nachfokussieren L1 + L2 in cm	45 + 60	45 + 60
Beleuchtungsstärke im Reservelampenbetrieb (in %)	100 %	100 %
Automatische Umschaltung	ja	ja
Nominelle Leistung Leuchtmittel 1 (in W)	150	120
Nominelle Leistung Leuchtmittel 2 (in W)	150	120
Lampenlebensdauer Entladungs-/Halogenlampe (in h)	600 – 1.000	600 – 1.000
Lichtaustrittsfläche (in cm ²)	1963	1963
Durchmesser Leuchtenkörper (in cm)	65	65
Schattigkeit: 1 Schatter mit Tubus	27 %	27 %
Schattigkeit: 2 Schatter mit Tubus	40 %	40 %
Bedienung	steril/unsteril	steril/unsteril
Stufenlose Verstellung Feldgröße	ja	ja
Stufenlose Verstellung Beleuchtungsstärke	ja (optional)	ja (optional)

Technical Specifications	H5 PLUS	H5
Max. illuminance at a distance of 1 m (in lux)	130,000	85,000
Light field diameter, d10 (in cm)	16 – 26	16 – 24
Color temperature in Kelvin (K)	4,300	4,300
Color rendering index CRI	93	93
Luminous efficacy in lumen per watt (lm/W)	285	285
Average radiant energy: total radiant power/illuminance (mW/m ² x lx)	3.5	3.5
Working range (illumination depth) without refocusing, L1 + L2 (in cm)	45 + 60	45 + 60
Illuminance guaranteed by standby lamp (in %)	100%	100%
Automatic changeover to standby lamp (2 nd light source)	yes	yes
Nominal output, light source 1 (in W)	150	120
Nominal output, light source 2 (in W)	150	120
Lamp life, discharge/halogen lamp (in h)	600 – 1,000	600 – 1,000
Light emission surface (in cm ²)	1963	1963
Light head diameter (in cm)	65	65
Shadow dilution with tube and 1 mask	27%	27%
Shadow dilution with tube and 2 masks	40%	40%
Handling	sterile/non-sterile	sterile/non-sterile
Continuously adjustable light field diameter	yes	yes
Continuously adjustable illuminance	yes (optional)	yes (optional)

OP-Leuchten marLux®

Operating theatre lights marLux®

Lámparas de quirófano marLux®

Lampes opératoires marLux®

Lampade scialitiche marLux®



La lámpara con monorreflector. Con reflector central.

Con marLux KLS Martin le ha proporcionado una dimensión totalmente nueva a la clásica lámpara con monorreflector. El monorreflector poliesférico ha obtenido un reflector central conmutable adicional. Esto significa:

- Un total de 540 facetas en disposición calculada por ordenador, que dirigen la luz exactamente sobre el campo operatorio.
- Tubo de luz vertical uniforme con distribución homogénea de la luz (véase imagen a la derecha).
- No requiere un reenfoque al variar la distancia o cambiar la posición del paciente.
- Iluminación libre de sombras – la luz “fluye” alrededor de los cirujanos.

Le monorélecteur. Avec réflecteur central.

Avec marLux®, KLS Martin a révolutionné le monorélecteur classique. Le monorélecteur polysphérique est doté d'un réflecteur central activable séparément, soit:

- Un total de 540 réflecteurs dont la disposition est calculée par ordinateur et qui dirigent la lumière précisément sur le champ opératoire.
- Un cylindre de lumière vertical régulier avec répartition homogène de la lumière (voir photo de droite).
- Une mise au point ne nécessitant aucun ajustement en cas de modifications des distances ou de repositionnement du patient.
- Un éclairage sans ombres – la lumière «coule» autour des chirurgiens.

Características técnicas	H5 PLUS	H5
Iluminancia máxima a 1 m de distancia (en lux)	130.000	85.000
Diámetro del campo de luz, d10 (en cm)	16 – 26	16 – 24
Temperatura del color en kelvin (K)	4.300	4.300
Índice de reproducción cromática Ra	93	93
Eficacia luminosa, lumen/vatio (lm/W)	285	285
Densidad de energía: intensidad energética/iluminación (en mW/m ² x lx)	3,5	3,5
Rango operativo sin reenfoque L1 + L2 (en cm)	45 + 60	45 + 60
Iluminancia en funcionamiento con bombilla de reserva (en %)	100 %	100 %
Conmutación automática a la bombilla de reserva	sí	sí
Potencia nominal del medio de iluminación 1 (en W)	150	120
Potencia nominal del medio de iluminación 2 (en W)	150	120
Vida útil de la bombilla, bombilla de descarga/halógena (en h)	600 – 1.000	600 – 1.000
Superficie de emisión de luz (en cm ²)	1963	1963
Diámetro del cuerpo de la lámpara (en cm)	65	65
Iluminación residual: 1 máscara de sombreado, con tubo	27 %	27 %
Iluminación residual: 2 máscaras de sombreado, con tubo	40 %	40 %
Manejo	estéril/no estéril	estéril/no estéril
Ajuste en progresión continua del diámetro del campo de luz	sí	sí
Ajuste en progresión continua de la intensidad de iluminancia	sí (opcional)	sí (opcional)

Caractéristiques techniques	H5 PLUS	H5
Éclairage maximal à 1 m de distance (en lux)	130.000	85.000
Diamètre du champ lumineux d10 en cm	16 – 26	16 – 24
Température de couleur en kelvins (K)	4.300	4.300
Indice de rendu des couleurs Ra	93	93
Efficacité lumineuse en lumen/watt (lm/W)	285	285
Luminance = intensité lumineuse/éclairage (en mW/m ² x lx)	3,5	3,5
Zone de travail sans refocalisation L1/L2 en cm	45/60	45/60
Éclairage fourni par la lampe de réserve (en %)	100 %	100 %
Commutation automatique	oui	oui
Puissance nominale de la lampe 1 (en W)	150	120
Puissance nominale de la lampe 2 (en W)	150	120
Durée de vie des lampes à décharge gazeuse/halogènes (en h)	600 – 1.000	600 – 1.000
Surface émettrice totale (en cm ²)	1963	1963
Diámetro del corps du luminaire (en cm)	65	65
Dilution des ombres: 1 masque d'ombre avec tube	27 %	27 %
Dilution des ombres: 2 masques d'ombre avec tube	40 %	40 %
Commande	stérile/non stérile	stérile/non stérile
Réglage en continu du diamètre du champ	oui	oui
Réglage en continu de l'éclairage	oui (en option)	oui (en option)

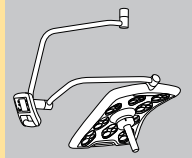

La lampada monofaro. Con riflettore centrale.

Con marLux® KLS Martin ha conferito alla classica lampada monofaro una dimensione completamente nuova. Il monoriflettore polisferico è stato dotato di un ulteriore riflettore centrale azionabile secondo necessità. Ciò significa:

- 540 riflettori in tutto con una disposizione calcolata dal computer che guidano il fascio di luce esattamente sul campo operatorio.
- Fascia di luce verticale con distribuzione omogenea della luce (vedi figura a destra).
- Nessuna necessità di nuova messa a fuoco in caso di modifiche della distanza o di spostamento dalla posizione originaria del paziente.
- Illuminazione priva di ombre – la luce “aggira” il chirurgo.

Dati tecnici	H5 PLUS	H5
Intensità di illuminazione mass. alla distanza di 1 m (in Lux)	130.000	85.000
Diametro del campo luminoso d10 in cm	16 – 26	16 – 24
Temperatura del colore in Kelvin (K)	4.300	4.300
Indice di resa del colore Ra	93	93
Equivalente di radiazione fotometrico (lm/W)	285	285
Intensità di irradiazione/illuminazione in mW/m ² x lx	3,5	3,5
Campo di lavoro senza nuova messa a fuoco L1 + L2 (in cm)	45 + 60	45 + 60
Intensità di illuminazione lampadina di riserva (in %)	100 %	100 %
Commutazione automatica	si	si
Potenza nominale sorgente luminosa 1 (in W)	150	120
Potenza nominale dispositivo luminoso 2 (in W)	150	120
Durata utile della lampadina a scarica di gas / lampadina alogena (in h)	600 – 1.000	600 – 1.000
Superficie di fuoriuscita della luce (in cm ²)	1963	1963
Diametro corpo lampada (in cm)	65	65
Intensità d'illuminazione residua: 1 disco con tubo	27 %	27 %
Intensità d'illuminazione residua: 1 dischi con tubo	40 %	40 %
Utilizzo	sterile/non sterile	sterile/non sterile
Regolazione continua della dimensione del campo luminoso	si	si
Regolazione continua dell'intensità di illuminazione	si (opzionale)	si (opzionale)

Kamerasysteme surgiCam

Camera systems surgiCam

Sistemas de cámara surgiCam

Systèmes de caméras surgiCam

Sistemi di telecamere surgiCam



surgiCam kann wahlweise am separaten Arm (Abb. links) oder zentral im Handgriff der OP-Leuchte ausgerüstet werden (Abb. rechts).

surgiCam can optionally be installed at the separate arm or centrally in the handle of the OR-Light.

surgiCam puede equiparse facultativamente en un brazo individual (véase fig. izq.) o de forma central en el mango de la lámpara de quirófano (véase fig. dcha.).

surgiCam peut, au choix, être montée sur le bras séparé (fig. de gauche) ou au milieu de la poignée de l'éclairage opératoire (fig. de droite).

surgiCam può essere montata a scelta su braccio separato (figura a sinistra) o centralmente nell'impugnatura della lampada scialitica (figura a destra).

Die Economy-Version. Die preiswerte Einzellösung.

Die Economy-Version zentral im Leuchtenkörper ermöglicht Ihnen die Funktionssteuerung von Zoom und Bildaufrichtung direkt vom Bedienfeld der Leuchte. Ohne weitere Steuergeräte. Per TFT-Bildschirm wird der OP-Ablauf für das gesamte Team visualisiert und das Videosignal per S-Video-Schnittstelle für Aufzeichnungen oder Weiterverarbeitung bereitgestellt.

Die Basis-Version. Komfortabel und brillant.

Die Basis-Version bietet Ihnen eine brillante Bildqualität sowie ein separates, komfortables Steuergerät, das wahlweise auf einer Deckenversorgungseinheit oder einem Gerätewagen platziert werden kann. Es umfasst eine Reihe weiterer Steuerfunktionen und ermöglicht die Umschaltung auf bis zu zwei weitere Videoquellen, z.B. eine Endoskopie- oder Raumkamera.

Die Voll-Version. Das Tor in die digitale Welt.

Die Voll-Version ist mit einem Videoserver ausgestattet, der die aufgenommenen Bildsignale digitalisiert, um diese in ein Netzwerk zu streamen. So können die digitalen Bilddaten via LAN vernetzt und auf serverbasierten Datenbanken aufgezeichnet werden. Darüber hinaus sind Liveübertragungen in Echtzeit und über große Distanzen problemlos möglich. Das System eignet sich ideal für Dokumentation, Ausbildung und Schulung. Über kennwortgeschützte Zugriffssteuerung lässt sich die Kamera in allen Funktionen von PC-Arbeitsplätzen außerhalb des OP's fernsteuern.

The Economy Version. The Low-Cost Single Solution.

The Economy version – positioned inside the light head – allows you to control the zoom and image erection functions directly via the operating light's control panel. No other control units required. Via a TFT monitor, the surgical procedure is visualized for the entire team. Besides, an S-video interface ensures the convenient recording or processing of the video signals.

The Basic Version. Convenient and Brilliant.

The Basic version offers you excellent image quality along with a separate, user-friendly control unit that can be installed either on the platform of a ceiling-mounted supply-and-suspension system or on an equipment trolley. It provides you with a number of additional control functions and allows optional switch-over to up to two other video sources (e.g. an endoscopic and a room camera).

The Advanced Version. The Gate to the Digital World.

The Advanced version features a video server capable of digitizing the recorded video signals and streaming them into a network. In this way, the digital image data can be distributed and used throughout a LAN and stored in server-based databases. Besides, live transmissions are easily possible in real time and over large distances. The system is ideal for documentation and training purposes. Password-protected access control ensures that all functions of the camera can be conveniently remote-controlled from PC workstations outside the operating room.

La versión Economy. La solución individual económica.

La versión Economy, localizada en el centro del cuerpo de la lámpara, le permite controlar el funcionamiento del zoom y de la erección de la imagen directamente desde el panel de control de la lámpara, sin necesidad de otras unidades de mando. A través de una pantalla plana TFT se visualiza toda la secuencia de la intervención quirúrgica para todo el equipo, poniéndose además a disposición la señal de vídeo mediante interfaz S-Video para grabaciones o un procesamiento ulterior.

La versión básica. Confortable y brillante

La versión básica le ofrece una calidad de imagen brillante, así como una confortable unidad de mando individual, que facultativamente puede colocarse en una unidad de alimentación de techo o en un carro portaequipos. Le proporciona toda una serie de funciones de control adicionales y hace posible la conmutación hacia hasta dos fuentes de vídeo suplementarias, por ejemplo una cámara endoscópica y una cámara de habitación.

La versión completa. El portal hacia el mundo digital.

La versión completa está equipada con un servidor de vídeo, que digitaliza las señales de vídeo registradas para transmitir las a continuación a una red informática. De este modo pueden integrarse en red los datos de vídeo digitales a través de una red de área local (LAN), guardándolos en bases de datos basadas en servidor. Además son posibles sin ningún problema transmisiones en vivo en tiempo real y cubriendo grandes distancias. El sistema es ideal para propósitos de documentación, formación y perfeccionamiento. La cámara puede controlarse a distancia en todas sus funciones a través de un control de acceso protegido por contraseña desde estaciones de trabajo PC situadas fuera del quirófano.

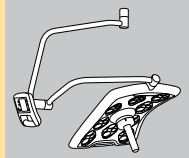

La version Economy.
 La solution individuelle bon marché.

La version Economy montée au centre du corps de luminaire vous permet de commander les fonctions du zoom et du dispositif de redressement d'image directement à partir du tableau de commande de l'éclairage. Sans autres appareils de commande. Le déroulement de l'intervention est visualisé pour l'ensemble de l'équipe via un moniteur TFT et le signal vidéo pour des enregistrements ou des traitements ultérieurs est fourni par une interface S-vidéo.

La versione Economy. La soluzione singola dal prezzo vantaggioso.

La versione Economy, situata centralmente nel corpo della lampada, permette la regolazione delle funzioni, dallo zoom all'impostazione dell'immagine, direttamente dal quadro di comando della lampada. Senza necessità di ulteriori apparecchi di comando. L'andamento dell'operazione viene visualizzato per tutta l'équipe su schermo TFT ed il segnale video viene approntato tramite interfaccia S-Video per le registrazioni o per essere ulteriormente elaborato.

La version de base.
 Conviviale et brillante.

La version de base vous offre une qualité d'image brillante ainsi qu'un appareil de commande séparé convivial qui peut être placé, au choix, sur un statif de plafond ou sur un chariot pour appareils. Il met à votre disposition une série d'autres fonctions de commande et permet de commuter sur jusqu'à deux autres sources vidéo, par ex. une caméra endoscopique ou une caméra de surveillance de la pièce.

La versione di base.
 Confortevole e brillante.

La versione di base offre una qualità brillante dell'immagine ed un apparecchio di comando separato e comodo, collocabile a scelta su un'unità di alimentazione a soffitto o su un carrello per apparecchi. Essa comprende tutta una serie di ulteriori funzioni di comando e rende possibile la commutazione fino a due altre fonti video, p.es. ad una telecamera endoscopica o ad una telecamera ambiente.

La version avancée.
 L'accès au monde numérique.

La version avancée est équipée d'un serveur vidéo qui numérise les signaux d'images enregistrés afin de les transmettre à un réseau. Les données d'images numériques peuvent ainsi être mises en réseau via LAN et enregistrées dans des bases de données basées sur des serveurs. Par ailleurs, des retransmissions en direct en temps réel et sur de grandes distances sont possibles sans problème. Le système est idéal pour les comptes-rendus, les formations et les stages. Une commande d'accès protégée par mot de passe permet de télécommander toutes les fonctions de la caméra à partir de postes de travail sur PC situés à l'extérieur de la salle d'opération.

La versione integrale. La porta di accesso al mondo digitale.

La versione integrale è munita di video server, per la digitalizzazione dei segnali immagine registrati, i quali possono essere trasmessi in rete via streaming. In questo modo è possibile collegare in rete i dati immagine tramite LAN e registrarli su banche dati su base server. Inoltre è possibile trasmettere dal vivo in tempo reale e su grandi distanze senza problemi. Il sistema si adatta perfettamente a scopi di documentazione, formazione e training. La telecamera può essere comandata a distanza in tutte le funzioni da PC situati all'esterno della sala operatoria, tramite controllo di accesso protetto da password.

Farbbildschirm-Systeme und Zubehör surgiCam

Flat screen systems and accessories surgiCam

Sistemas de pantalla a color y accesorios surgiCam

Systèmes à moniteurs en couleurs et accessoires surgiCam

Sistemi di monitor a colori e accessori surgiCam



TFT-Monitore medTFTpro

TFT-Monitore sind leicht, kompakt und von hoher Bildqualität. Die Integration in eine decken-hängende OP-Leuchtenkombination erlaubt die äußerst flexible Positionierung im Raum. Die Vorteile dieser Kombination aus Bildschirm und Tragsystem liegen in der hohen Beweglichkeit, dem geringen Eigengewicht und gegebenenfalls in einer anschlagfreien Aufhängung. Eine hohe Auflösung und schnelle Bildwechselraten bilden die Voraussetzungen für beste Bildqualität.

medTFTpro Monitors

TFT monitors are not only light-weight and compact, but offer excellent image quality as well. Integration into a ceiling-mounted multi-light setup provides maximum flexibility in positioning the monitor according to specific needs. The advantages of a monitor plus suspension system combination are in fact easy to see: high mobility, low weight, plus easy handling thanks to an optionally available stop-free suspension. First-rate image quality is guaranteed by high resolution and a high frame frequency.

Pantallas planas medTFTpro

Las pantallas TFT son ligeras, compactas y, además, ofrecen una calidad de imagen excelente. La integración en una combinación de lámparas de quirófano montada en el techo proporciona una flexibilidad máxima posicionando la pantalla en función de las necesidades. Las ventajas de esta combinación de pantalla y sistema portante residen en la alta movilidad, el bajo peso y una libertad de maniobra sencilla gracias a una suspensión sin topes disponible como opción. Las premisas para conseguir la mejor calidad de imagen son la alta resolución y una frecuencia de barrido vertical rápida.

Moniteurs TFT medTFTpro

Les moniteurs TFT sont légers, compacts et offrent une grande qualité d'image. L'intégration dans une combinaison d'éclairages opératoires accrochés au plafond permet un positionnement extrêmement flexible dans la pièce. Les avantages d'un écran associé à un système de support sont la grande mobilité, le faible poids propre et, le cas échéant, une suspension sans butées. Une résolution élevée et des fréquences d'image rapides sont les conditions préalables à une qualité d'image optimale.

Monitor TFT medTFTpro

I monitor TFT sono leggeri, compatti ed offrono una qualità elevata dell'immagine. L'integrazione in una combinazione di lampade scialitiche con sospensione a soffitto consente la massima flessibilità di posizionamento nella stanza. I vantaggi di questa combinazione di monitor e sistema portante riguardano la mobilità elevata, il peso singolo limitato ed eventualmente la sospensione priva di arresti. L'alta risoluzione e le sequenze rapide di cambio immagine costituiscono le premesse per la migliore qualità assoluta dell'immagine.

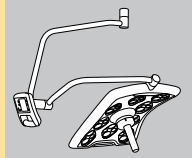

KLS-Martin-Geräteträger GTP 14

Der KLS Martin Geräteträgerarm bietet hier eine ideale Lösung für die platzsparende Aufstellung häufig verwendeter Gerätekomponenten wie HF-Geräte, Kaltlichtquellen, etc.

KLS Martin device support GTP 14

The KLS Martin device support arm offers an ideal solution for the space-saving installation of frequently used systems such as HF units, cold-light sources etc.

Brazo portaequipos GTP 14 de KLS Martin

El brazo portaequipos de KLS Martin aporta la solución ideal para la disposición racional de aparatos frecuentemente utilizados como equipos de AF, fuentes de luz fría, etc.

Bras de support pour appareils GTP 14 de KLS Martin

Ce bras de support pour appareils de KLS Martin constitue une solution idéale pour la mise en place peu encombrante de composants d'appareils souvent utilisés comme des appareils HF, des sources de lumière froide etc.

Supporto per apparecchi GTP 14 di KLS Martin

Il braccio di supporto per apparecchi di KLS Martin costituisce la soluzione ideale per il montaggio salvaspazio di componenti spesso utilizzati, quali apparecchi AF, fonti di luce fredda, ecc.

Entdecken Sie weitere Produktgruppen von KLS Martin
Explore other product groups of KLS Martin
Descubra más grupos de productos de KLS Martin
Découvrez les autres groupes de produits de KLS Martin
Scopri di più gruppi di prodotti di KLS Martin

marLED® –

*Ausgezeichnetes Licht mit
LEDs der zweiten Generation*

Mit seinem konstruktiv und lichttechnisch radikal neuen Gesamtansatz setzt KLS Martin neue Maßstäbe in der Ausleuchtung selbst schwieriger Operationsfelder. marLED® wurde ausgezeichnet mit dem Focus Green 2008 in Silber.



Operating Lights



reddot design award
winner 2008



Focus Green
Silber 2008



GB

marLED® – Excellent light
with second generation LEDs

With its radically new overall approach to design and light technology, KLS Martin has set new standards for illuminating even difficult surgery areas. marLED® has received the Focus Green Silver 2008 award.

ES

marLED® – Excelente luz
con los diodos luminosos de
la segunda generación

Con un enfoque radicalmente novedoso tanto desde la perspectiva del diseño como desde la perspectiva de la técnica de iluminación, KLS Martin marca nuevas pautas de iluminación, aplicables incluso en los campos quirúrgicos más complejos. marLED® ha sido galardonado con el premio "Focus Green Silver 2008".

F

marLED® – Excellent éclairage
grâce à des DEL de la
seconde génération

Avec sa conception globale constructive et radicalement novatrice en matière de technologie d'éclairage, KLS Martin définit de nouveaux standards en matière d'éclairage, même pour des champs opératoires difficiles. marLED® a remporté le prix « Focus Green Silver 2008 ».

I

marLED® – Luce ottimale
con LED di seconda genera-
zione

Grazie ad un approccio globale radicalmente nuovo dal punto di vista progettuale e nella tecnica dell'illuminazione, KLS Martin ha definito nuovi criteri nell'illuminazione di complessi campi operatori. marLED® ha ottenuto il "Focus Green Silver 2008".

OP-Leuchten marLED®

Operating theatre lights marLED®

Lámparas de quirófano marLED®

Lampes opératoires marLED®

Lampade scialitiche marLED®



marLED® V10

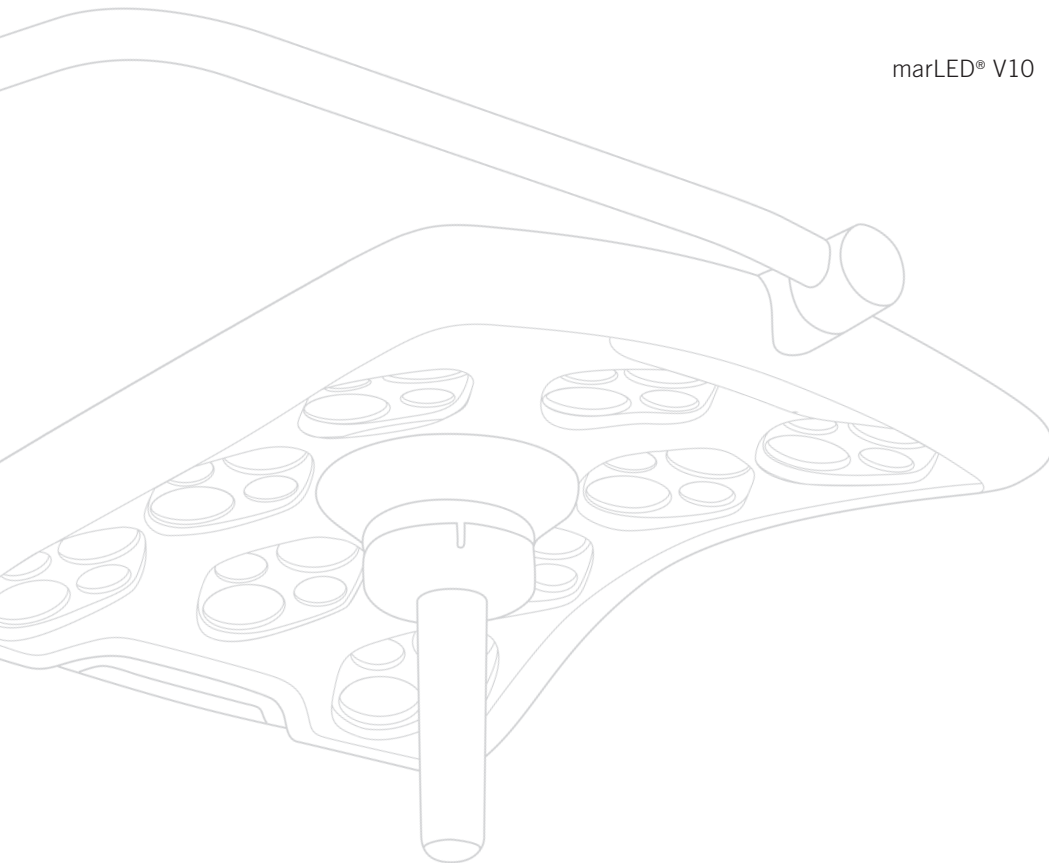

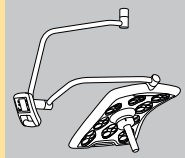

Ausgezeichnet in Funktion und Form

Mit marLED® beschreitet KLS Martin neue Wege in der Operationsfeldbeleuchtung – und bietet nun als Ergänzung zu der Gasentladungs- und Halogenleuchtenserie marLUX® eine innovative LED-Linie. Neue Wege? Operationsleuchten auf LED-Basis gibt es schon länger – marLED® hingegen ist neu und verwendet durchweg LED-Chips der zweiten Generation: kleiner, kompakter, effizienter in der Lichtausbeute, sparsamer im Stromverbrauch.

marLED® überzeugt aber nicht allein durch konstruktive und lichttechnische Vorteile. Die neue Operationsleuchte basiert auf einem radikal neuen Optik- und Gehäusekonzept. Ein wegweisendes Design verbindet Ergonomie und Gehäusekonzept. Ein wegweisendes Design verbindet Ergonomie mit Technologie und erzeugt in jedem modernen Operationssaal die optimale Arbeitsatmosphäre. Für seine herausragende Form wurde marLED® schon jetzt mit international renommierten Design-Awards ausgezeichnet.

Outstanding in Form and Function

With marLED®, KLS Martin treads new paths in surgical field illumination – now offering an innovative LED line in addition to the marLUX® halogen and gas discharge series of operating lights. New paths? Yes. Although it is true that LED-based operating lights have been around for some time, marLED® is new because it exclusively uses LED chips of the second generation: smaller and more compact, with superior light yield yet lower power consumption.

marLED®'s advantages, however, are by no means limited to design and lighting technology. In fact, this novel operating light is based on a radically new optical and housing concept. Its trailblazing design harmoniously combines ergonomics and technology, bringing an optimal working atmosphere to any state-of-the-art operating room. And despite being a newcomer to the market, marLED® has already won internationally renowned design awards on the merits of its outstanding form.

Technische Daten	marLED® V10
Max. Beleuchtungsstärke	110.000 lx
Felddurchmesser	23 – 33 cm, wahlweise zirkular oder oval
Farbtemperatur	3800 – 4800 K variabel
Farbwiedergabeindex Ra	95
Photometrisches Strahlungsäquivalent	289 lm/W
Ausleuchtungstiefe L1 + L2	129 cm
Dimmbarkeit	30 – 100 % (2 – 29 %: backLite-Betrieb)
Lichtquellen	Hochleistungs-LEDs, gebündelt in 10 Light Engines
Lebensdauer der LED's	25.000 h – 30.000 h
Bedienung	Steril über sensoGrip Unsteril mittels sensoTouch Panel backLite Hintergrundbeleuchtung für die Endoskopie
Leuchtenkörper-Aufhängung	vollkardanisch
Abmessungen Leuchtenkörper	ca. 64 x 46 cm
Optionen	Kamerasystem surgiCam SD und HD Interface für integrierte OP-Systeme LC-Version für niedrige Räume Wandbedienung
Erweiterbar mit	TFT-Armen, Kamera-Arm, Geräteträgerplatte, Chirurgiestativ

All lighting values are subject to a tolerance of ± 5 % due to manufacturing and metrological reasons.

Technical Data	marLED® V10
Max. illuminance	110,000 lx
Light field diameter	23 – 33 cm (options: circular or oval)
Color temperature	3800 – 4800 K, variable
Color rendering index (CRI)	95
Luminous efficacy	289 lm/W
Illumination depth	129 cm
Dimming range	30 – 100% (2 – 29 %: backLite operation)
Light sources	High-performance LEDs, arranged into 10 "light engines"
LED service life	25,000 h – 30,000 h
Operation	Sterile via sensoGrip Non-sterile via sensoTouch panel backLite background illumination for endoscopy
Light head suspension	fully cardanic
Light head diameter	approx. 64 x 46 cm
Optional accessories	surgiCam SD and HD camera systems Interface for integrated OR systems LC suspension system for low rooms Wall operation
Extension options	TFT arms, camera arm, arm system with device platform, ceiling pendant system for surgery

All lighting values are subject to a tolerance of ± 5 % due to manufacturing and metrological reasons.

OP-Leuchten marLED®

Operating theatre lights marLED®

Lámparas de quirófano marLED®

Lampes opératoires marLED®

Lampade scialitiche marLED®



Excelente en función y forma

KLS Martin explora con marLED® nuevos senderos en materia de iluminación del campo operatorio y ofrece ahora una línea innovadora de LED como complemento a la serie marLUX® de lámparas de halógeno y de descarga de gas. ¿Nuevos senderos? Las lámparas de quirófano basadas en tecnología LED existen hace ya desde largo tiempo; marLED®, por el contrario, es nueva y en ella se emplean sin excepción chips de la segunda generación de tecnología LED: más pequeños, más compactos, con un rendimiento luminoso más eficiente y un consumo de energía más económico.

marLED®, sin embargo, no sólo convence por sus ventajas constructivas y luminotécnicas. La nueva lámpara de quirófano está basada en un concepto radicalmente nuevo de óptica y carcasa. Uniendo ergonomía y tecnología en un diseño de vanguardia, ofrece a toda sala quirúrgica moderna la atmósfera óptima de trabajo. Por su forma original, marLED® ya ha sido objeto de famosos reconocimientos internacionales de diseño.

L'excellence de la fonction et de la forme

Avec marLED®, KLS Martin prend de nouvelles orientations dans le domaine de l'éclairage des champs opératoires – et propose maintenant une ligne LED innovante en complément de la série de luminaires à décharge gazeuse et halogènes marLUX®. Pourquoi de nouvelles orientations? Les luminaires opératoires à base de LED existent depuis un certain temps – en revanche marLED® est une nouveauté et utilise uniquement des puces LED de la deuxième génération: plus petites, plus compactes, plus efficaces en terme d'éclairage, plus économes en électricité.

Mais marLED® ne convainc pas seulement par ses avantages de conception et de technique d'éclairage. Le nouveau luminaire opératoire est basé sur un concept radicalement nouveau de l'optique et du corps. Un design d'avenir associe ergonomie et technologie et génère une atmosphère de travail optimale dans toutes les salles d'opération modernes. La forme remarquable de marLED® lui a déjà valu des prix de design de renommée internationale.

Características técnicas	marLED® V10
Iluminancia máx.	110.000 lx
Diámetro de campo	de 23 a 33 cm, alternativamente circular u oval
Temperatura de color	de 3800 a 4800 K variable
Índice de reproducción cromática Ra	95
Eficacia luminosa	289 lm/W
Profundidad de iluminación (L1+L2)	129 cm
Atenuación	30 – 100 % (2 – 29 %: en modo de funcionamiento backLite)
Fuente lumínica	Varios LED de alto rendimiento, agrupados en 10 motores de luz
Vida útil de los LED	25.000 h – 30.000 h
Manejo	Estéril: mediante sensoGrip No estéril: a través del panel sensoTouch Iluminación de fondo backLite para la endoscopia
Suspensión del cuerpo de la lámpara	totalmente cardánica
Medidas del cuerpo de la lámpara	aprox. 64 x 46 cm
Opciones	Sistema de cámara surgiCam SD y surgiCam HD Interfaz para sistemas integrados de operaciones Sistema de suspensión LC (low ceiling version) para espacios de poca altura Manejo mural
Extensible con	Brazos portantes de TFT; brazo portante de cámara; base de soporte de equipos y unidad de alimentación de techo

Todos los valores luminotécnicos están sujetos a una tolerancia de $\pm 5\%$ por razones de fabricación y de metrología.

Caractéristiques techniques	marLED® V10
Eclairage maxi.	110.000 lx
Diamètre du champ lumineux	23 – 33 cm, circulaire ou ovale au choix
Température de couleur	3.800 – 4.800 K variable
Indice de rendu des couleurs Ra	95
Efficacité lumineuse du rayonnement	289 lm/W
Profondeur d'éclairage (L1 + L2)	129 cm
Intensité variable	30 – 100 % (2 – 29 %: mode backLite)
Sources lumineuses	LED haute performance, par faisceaux de 10 moteurs de lumière
Durée de vie	25.000 h – 30.000 h
Manipulation	Stérile via sensoGrip Non stérile au moyen du panneau sensoTouch Eclairage d'arrière-plan backLite pour l'endoscopie
Suspension du corps de luminaire	entièrement cardanique
Diamètre du corps de luminaire	env. 64 x 46 cm
Options	Systèmes de caméra surgiCam SD et HD Interface pour systèmes opératoires intégrés Version LC pour plafonds bas Commande murale
Extension possible avec	Bras TFT, bras pour caméra, système de support pour appareils, statif chirurgical

Toutes les valeurs d'éclairage sont sujettes à une tolérance de $\pm 5\%$ pour des raisons de fabrication et de métrologie.

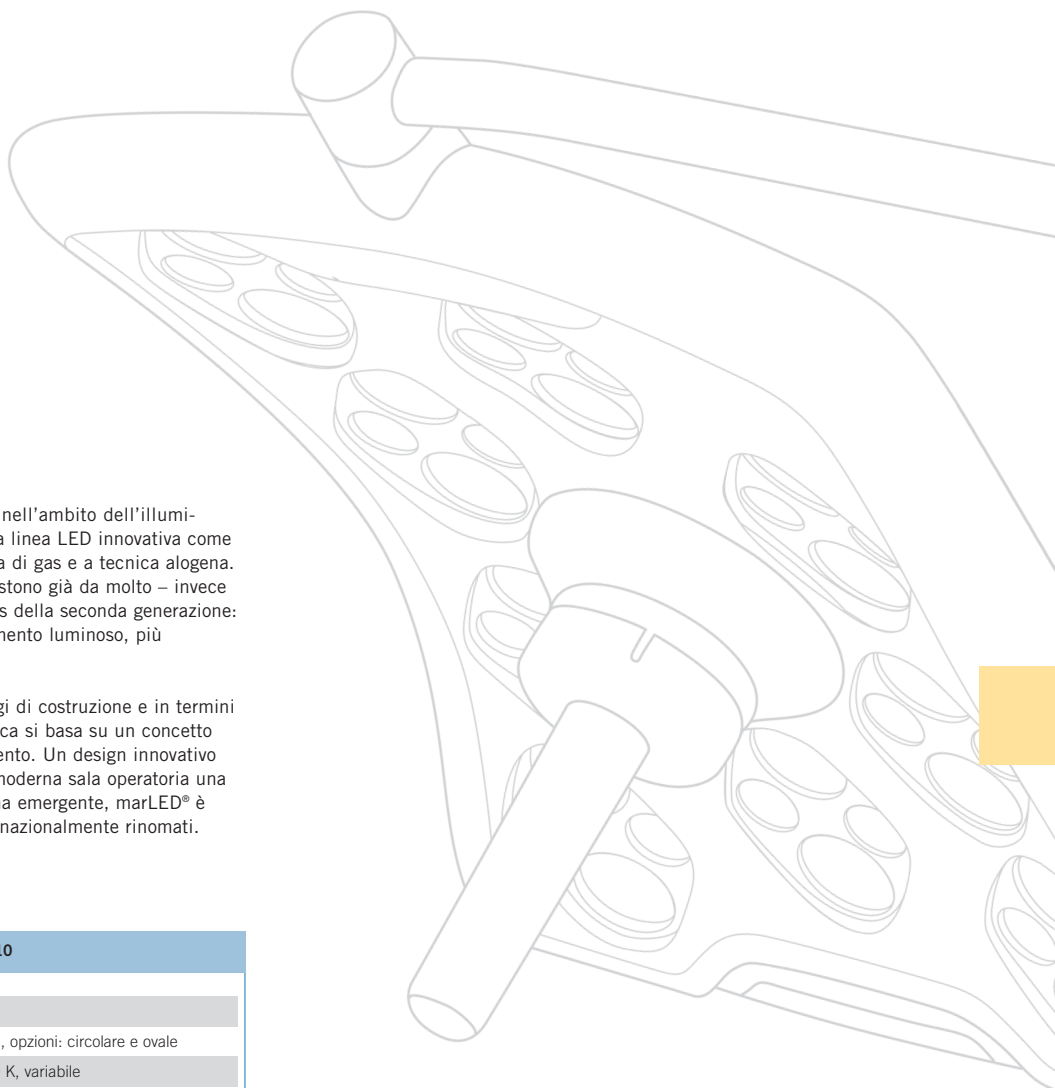

Eminente per funzionalità e forma

Con marLED® KLS Martin percorre nuove strade nell'ambito dell'illuminazione del campo operatorio – e propone ora una linea LED innovativa come ampliamento della serie marLUX® di luci a scarica di gas e a tecnica alogena. Nuove strade? Le luci scialitiche su base LED esistono già da molto – invece marLED® è nuova ed utilizza completamente chips della seconda generazione: più piccoli, più compatti, più efficienti nel rendimento luminoso, più contenuti nel consumo di energia elettrica.

marLED® però non convince soltanto per i vantaggi di costruzione e in termini di tecnologia luminosa. La nuova lampada scialitica si basa su un concetto completamente nuovo dell'ottica e dell'alloggiamento. Un design innovativo coniuga ergonomia e tecnologia creando in ogni moderna sala operatoria una perfetta atmosfera lavorativa. Grazie alla sua forma emergente, marLED® è stata insignita già adesso di premi di design internazionalmente rinomati.

Dati tecnici	marLED® V10
Intensità max. di illuminazione	110.000 lx
Diametro campo luminoso	23 – 33 cm, opzioni: circolare e ovale
Temperatura del colore	3800–4800 K, variabile
Indice di riproduzione cromatica Ra	95
Equivalente di radiazione fotometrico	289 lm/W
Profondità di illuminazione (L1+L2)	129 cm
Dimming (gradazione intensità luminosa)	30 – 100 % (2-29 % modalità backLite)
Sorgenti luminose	LED ad alta prestazione, a fasci di 10 motori luminosi ("light engines")
Vita utile dei LED	25.000 h – 30.000 h
Comando	Sterile tramite sensoGrip Non sterile tramite pannello sensoTouch Retroilluminazione backLite per uso endoscopico
Sospensione del corpo della lampada	Completamente cardanica
Diametro corpo della lampada	ca. 64 x 46 cm
Opzioni	Sistema di telecamere surgiCam SD e HD Interfaccia per sistemi operatori integrati Versione LC per ambienti a soffitto basso Comando a parete
Ampliabile con	Bracci TFT, braccio per telecamera, braccio con piattaforma portaapparecchi, sistema di sospensione a soffitto per uso chirurgico

Tutti i valori di illuminazione sono soggetti ad un margine di tolleranza pari a $\pm 5\%$ per ragioni di produzione e di metrologia.

18

Chirurgische Sauger

Suction cannulas
Tubos de aspiración
Cannulas d'aspiration
Tubi d'aspirazione

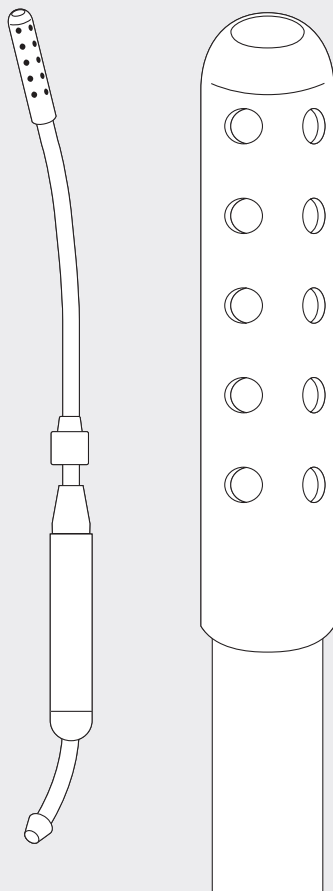

Saugrohre

Suction Cannulas
Tubos de aspiración
Tubes d'aspiration
Tubi d'aspirazione



1/1



18-501-14
14 cm / 5 1/8"
Ø 1,5 mm



18-502-14
14 cm / 5 1/8"
Ø 2,5 mm



18-503-14
14 cm / 5 1/8"
Ø 3,0 mm

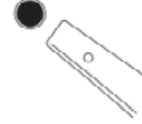

18-504-14
14 cm / 5 1/8"
Ø 4,0 mm



18-506-14
14 cm / 5 1/8"
Ø 6,0 mm

1/2

18-501-14 - 18-506-14



1/1



18-501-18
18 cm / 7 1/8"
Ø 1,5 mm



18-502-18
18 cm / 7 1/8"
Ø 2,5 mm



18-503-18
18 cm / 7 1/8"
Ø 3,0 mm



18-504-18
18 cm / 7 1/8"
Ø 4,0 mm

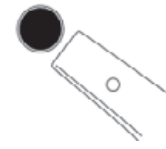

18-506-18
18 cm / 7 1/8"
Ø 6,0 mm

1/2

18-501-18 - 18-506-18



Knochenfalle siehe Seite 149
Bonetrapp see page 149
Colector óseo miren página 149
Collecteur d'os voir page 149
Raccoglio osso vedi pagina 149

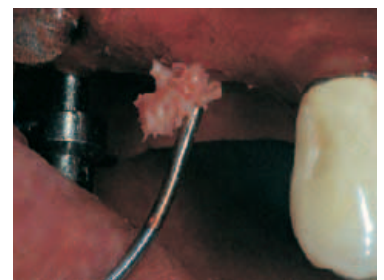

Saugrohre
Suction Cannulas
Tubos de aspiración
Tubes d'aspiration
Tubi d'aspirazione

Chirurgische Sauger
Suction cannulas
Tubos de aspiración
Cannulas d'aspiration
Tubi d'aspirazione

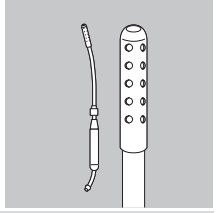

1/2

18-523-06	19,5 cm / 7 5/8"	Ø 2,0 mm
18-523-07	19,5 cm / 7 5/8"	Ø 2,3 mm
18-523-08	19,5 cm / 7 5/8"	Ø 2,7 mm
18-523-09	19,5 cm / 7 5/8"	Ø 3,0 mm
18-523-10	19,5 cm / 7 5/8"	Ø 3,3 mm
18-523-11	19,5 cm / 7 5/8"	Ø 3,6 mm
18-523-12	19,5 cm / 7 5/8"	Ø 4,0 mm
18-523-13	19,5 cm / 7 5/8"	Ø 5,0 mm

Frazier
18-523-06 - 18-523-13

18



1/2

Luer
18-529-30 - 18-529-45

konisch
conical
cónico
conique
conico

1/4

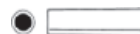

18-529-30
16,5 cm / 6 4/8"
Ø 3,0 mm
Arbeitslänge
working length
largo útil
longueur utile
lunghezza utile
110 mm



18-529-35
16,5 cm / 6 4/8"
Ø 3,5 mm
Arbeitslänge
working length
largo útil
longueur utile
lunghezza utile
110 mm



18-529-45
18 cm / 7 4/8"
Ø 4,5 mm
Arbeitslänge
working length
largo útil
longueur utile
lunghezza utile
130 mm

Saugeraufsätze, Saugrohre

Suction tips, suction tubes

Punta de succión, tubos de aspiración

Pointe de succion, tubes d'aspiration

Punte per aspirazione, tubi d'aspirazione



Spitze seitlich perforiert
tip laterally perforated
punta perforada lateralmente
pointe côté perforée
punta con perforazione laterale



18-575-24



1/2

Coupland

18-575-24

17 cm / 6 5/8"

mit Schlauchansatz
with tube connector
con conexión para tubos
avec connection pour tubes
con raccordo per tubi



18-575-05

9 cm / 3 4/8"

Ø 1,5 mm



18-575-06

9 cm / 3 4/8"

Ø 2,0 mm



18-575-07

9 cm / 3 4/8"

Ø 2,5 mm

1/4



18-575-08

9 cm / 3 4/8"

Ø 3,5 mm



1/2

Cogswell

18-579-23

24,5 cm / 9 5/8"

Ø 3,8 mm

mit Unterbrecher
with finger cut-off
con placa desconectadona
avec plaque interrupteur
con placa interuttore

20

Nadelhalter, Mikro-Nadelhalter

Needle holders, micro needle holders

Porta agujas, micro porta agujas

Porte aiguilles, micro porte aiguilles

Portaghi, micro porta aghi

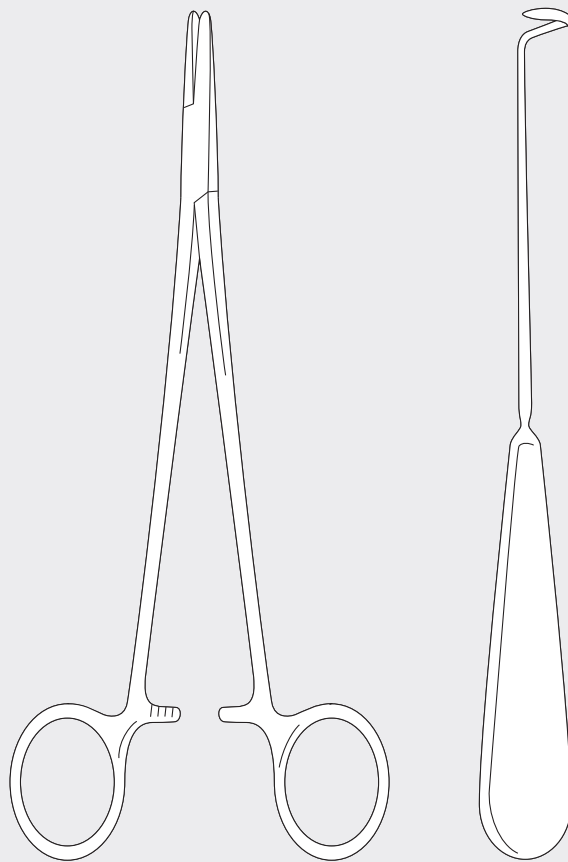

Mikro-Nadelhalter

Micro Needle Holders

Micro Porta-agujas

Micro porte-aiguilles

Micro Portaghi



1/2



safety-wave



diamond-coated



7-0 - 12-0

1/1



	mit Sperre with ratchet con trinquete avec cran d'arrêt con arresto	mit Sperre with ratchet con trinquete avec cran d'arrêt con arresto	ohne Sperre w/o ratchet sin trinquete sans cran d'arrêt senza arresto	ohne Sperre w/o ratchet sin trinquete sans cran d'arrêt senza arresto
	Ø 0.40 mm	Ø 0.40 mm	Ø 0.40 mm	Ø 0.40 mm
15 cm / 5 7/8"	St 20-002-15	20-003-15	20-004-15	20-005-15
15 cm / 5 7/8"	Ti 20-016-15	20-017-15	20-018-15	20-019-15
18 cm / 7 1/8"	St 20-002-18	20-003-18	20-004-18	20-005-18
18 cm / 7 1/8"	Ti 20-016-18	20-017-18	20-018-18	20-019-18



1/2



safety-wave



diamond-coated



7-0 - 12-0

1/1



	mit Sperre with ratchet con trinquete avec cran d'arrêt con arresto	mit Sperre with ratchet con trinquete avec cran d'arrêt con arresto	ohne Sperre w/o ratchet sin trinquete sans cran d'arrêt senza arresto	ohne Sperre w/o ratchet sin trinquete sans cran d'arrêt senza arresto
	Ø 0.80 mm	Ø 0.80 mm	Ø 0.80 mm	Ø 0.80 mm
15 cm / 5 7/8"	St 20-010-15	20-011-15	20-012-15	20-013-15
15 cm / 5 7/8"	Ti 20-020-15	20-021-15	20-022-15	20-023-15
18 cm / 7 1/8"	St 20-010-18	20-011-18	20-012-18	20-013-18
18 cm / 7 1/8"	Ti 20-020-18	20-021-18	20-022-18	20-023-18
21 cm / 8 2/8"	St 20-010-21	20-011-21	20-012-21	20-013-21
21 cm / 8 2/8"	Ti 20-020-21	20-021-21	20-022-21	20-023-21
23 cm / 9"	St 20-010-23	20-011-23	20-012-23	20-013-23

Mikro-Nadelhalter

Micro Needle Holders
Micro Porta-agujas
Micro porte-aiguilles
Micro Portaghi

Nadelhalter, Mikro-Nadelhalter

Needle holders, micro needle holders
Porta agujas, micro porta agujas
Porte aiguilles, micro porte aiguilles
Portaghi, micro porta aghi

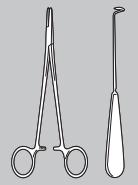

1/2



safety-wave



diamond-coated



4-0 - 7-0



	mit Sperre with ratchet con trinquete avec cran d'arrêt con arresto	mit Sperre with ratchet con trinquete avec cran d'arrêt con arresto	ohne Sperre w/o ratchet sin trinquete sans cran d'arrêt senza arresto	ohne Sperre w/o ratchet sin trinquete sans cran d'arrêt senza arresto
	Ø 0.7 mm	Ø 0.7 mm	Ø 0.7 mm	Ø 0.7 mm

18 cm / 7 1/8" St	20-100-18	20-101-18	20-102-18	20-103-18
--------------------------	-----------	-----------	-----------	-----------

Iglhaut
20-100-18 - 20-103-18
18 cm / 7 1/8"



20



1/2



safety-wave



diamond-coated



4-0 - 6-0

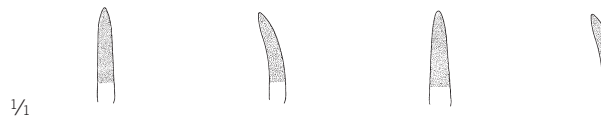

	mit Sperre with ratchet con trinquete avec cran d'arrêt con arresto	mit Sperre with ratchet con trinquete avec cran d'arrêt con arresto	ohne Sperre w/o ratchet sin trinquete sans cran d'arrêt senza arresto	ohne Sperre w/o ratchet sin trinquete sans cran d'arrêt senza arresto
	Ø 2,0 mm	Ø 2,0 mm	Ø 2,0 mm	Ø 2,0 mm

15 cm / 5 7/8" St	20-606-15	20-605-15	20-608-15	20-607-15
18 cm / 7 1/8" St	20-606-18	20-605-18	20-608-18	20-607-18
21 cm / 8 2/8" St	20-606-21	20-605-21	20-608-21	20-607-21
23 cm / 9" St	20-606-23	20-605-23	20-608-23	20-607-23

20-605-18 - 20-607-23

Mikro-Nadelhalter

Micro Needle Holders

Micro Porta-agujas

Micro porte-aiguilles

Micro Portaghi



1/2

Gregory
20-612-18 - 20-612-21

mit Sperre, doppelt übersetzt
with lock, double-action
con cierre, articulación doble
avec serrure, articulation double
con fermo, articolazione doppia



1/1
20-612-18
18 cm / 7 1/8"
2.0 mm



20-612-21
21 cm / 7 7/8"
2.0 mm



1/2

Castroviejo
20-316-13

12 cm / 4 3/4"
mit Sperre
with lock
con cierre
avec serrure
con fermo



1/2

Castroviejo
20-317-12

12 cm / 4 3/4"
mit Sperre
with lock
con cierre
avec serrure
con fermo

Nadelhalter

Needle Holders

Porta-agujas

Porte-aiguilles

Portaghi

Nadelhalter, Mikro-Nadelhalter

Needle holders, micro needle holders

Porta agujas, micro porta agujas

Porte aiguilles, micro porte aiguilles

Portaghi, micro porta aghi

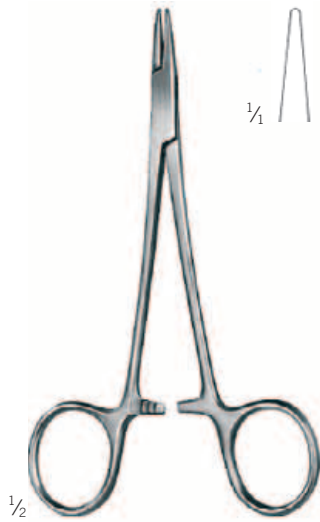
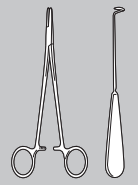

Webster
20-334-13

13 cm / 5 1/8"

glattes Maul
smooth jaw
boca lisa
mors lisse
morso liscio

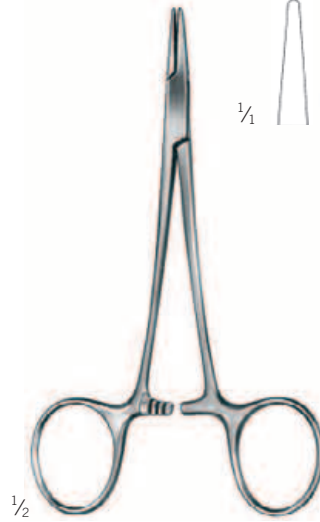

Halsey
20-336-13

13 cm / 5 1/8"

glattes Maul
smooth jaw
boca lisa
mors lisse
morso liscio



Crile-Murray
20-348-15

15 cm / 5 7/8"

schlankes Modell
slender pattern
modelo delgado
modèle gracile
modello gracile

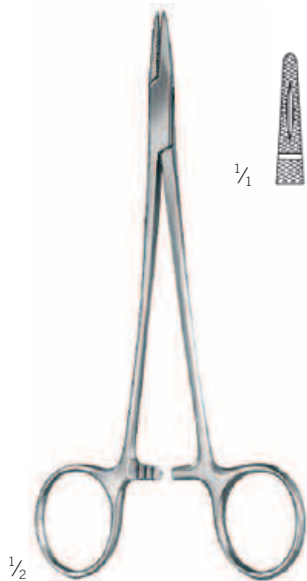

Crile-Wood
20-350-15

15 cm / 5 7/8"



Mayo-Hegar
20-390-14 - 20-390-20



20-390-14
14,5 cm / 5 6/8"



20-390-16
16 cm / 6 2/8"



20-390-18
18,5 cm / 7 2/8"



20-390-20
20,5 cm / 8 1/8"

Nadelhalter

Needle Holders

Porta-agujas

Porte-aiguilles

Portaghi



1/2

Mayo-Hegar
20-396-16 - 20-396-20

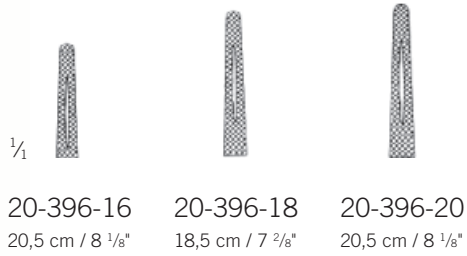

1/4

20-396-16
20,5 cm / 8 1/8"

20-396-18
18,5 cm / 7 2/8"

20-396-20
20,5 cm / 8 1/8"



1/2

Crile
20-500-15
15 cm / 6"

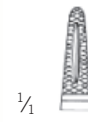

1/4

20-500-15
15 cm / 5 7/8"



1/2

Mathieu
20-516-14 - 20-516-20

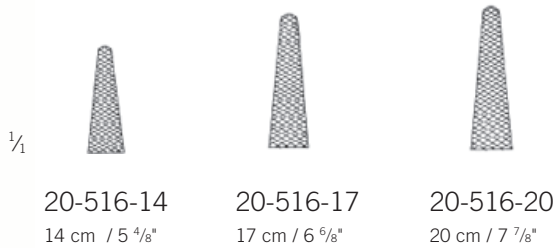

1/4

20-516-14
14 cm / 5 4/8"

20-516-17
17 cm / 6 6/8"

20-516-20
20 cm / 7 7/8"



1/2

Mathieu
20-526-14 - 20-526-17

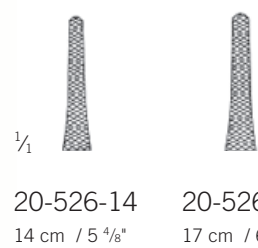

1/4

20-526-14
14 cm / 5 4/8"

20-526-17
17 cm / 6 6/8"

Nadelhalter

Needle Holders

Porta-agujas

Porte-aiguilles

Portaghi

Nadelhalter, Mikro-Nadelhalter

Needle holders, micro needle holders

Porta agujas, micro porta agujas

Porte aiguilles, micro porte aiguilles

Portaghi, micro porta aghi

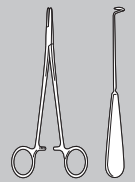

Toennis
20-574-18
18,5 cm / 7 3/8"

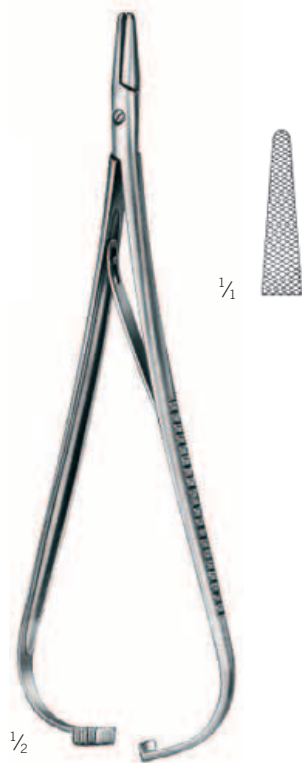

Lichtenberg
20-576-20
20 cm / 7 7/8"

TC GOLD



20-604-13 - 20-604-15



Webster
20-604-13
13 cm / 5 1/8"



Crile-Wood
20-604-15
15 cm / 5 7/8"

Miniprofil
mini profile
perfil mini
profil mini
profilo mini

mit Durchdrücksperrre auch für Linkshänder geeignet
with automatic release ratchet also for lefthanders
con cremallera automática también para zurdos
avec cremillère automatique aussi pour gauchers
con cremagliera automatica anche per mancini



4-0 - 6-0

Mikro-Nadelhalter

Micro Needle Holders

Micro Porta-agujas

Micro porte-aiguilles

Micro Portaghi

TC GOLD



1/2

Castroviejo
20-620-00 - 20-621-21

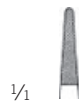

1/1

20-620-00
14,5 cm / 5 5/8"



5-0 - 8-0

Mikroprofil
micro profile
perfil micro
profil micro
profilo micro



20-620-01
14,5 cm / 5 5/8"



5-0 - 8-0

Mikroprofil
micro profile
perfil micro
profil micro
profilo micro



20-620-14
14,5 cm / 5 5/8"



6-0 - 12-0

glattes Maul
smooth jaw
boca lisa
mors lisse
morso liscio



20-620-18
18 cm / 7 1/8"



5-0 - 8-0

Mikroprofil
micro profile
perfil micro
profil micro
profilo micro



1/1

20-620-21
22 cm / 8 5/8"



5-0 - 8-0

Mikroprofil
micro profile
perfil micro
profil micro
profilo micro



20-621-14
14,5 cm / 5 5/8"



6-0 - 12-0

glattes Maul
smooth jaw
boca lisa
mors lisse
morso liscio



20-621-18
18 cm / 7 1/8"



5-0 - 8-0

Mikroprofil
micro profile
perfil micro
profil micro
profilo micro



20-621-21
22 cm / 8 5/8"



5-0 - 8-0

Mikroprofil
micro profile
perfil micro
profil micro
profilo micro



1/2

Castroviejo
20-624-13
12,5 cm / 4 7/8"

mit Sperre, glattes Maul
with lock, smooth jaw
con cierre, boca lisa
avec serrure, mors lisse
con fermo, morso liscio



1/1



6-0 - 12-0



1/2

Derf
20-632-12
12 cm / 4 5/8"

Miniprofil
mini profile
perfil mini
profil mini
profilo mini

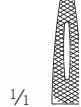

1/1



4-0 - 6-0



1/2

Hegar-Baumgartner
20-634-13 - 20-634-14

Miniprofil
mini profile
perfil mini
profil mini
profilo mini



1/1



4-0 - 6-0

20-634-13
13 cm / 5 1/8"



1/1



4-0 - 6-0

20-634-14
14,5 cm / 5 5/8"

Nadelhalter

Needle Holders
Porta-agujas
Porte-aiguilles
Portaghi

Nadelhalter, Mikro-Nadelhalter

Needle holders, micro needle holders
Porta agujas, micro porta agujas
Porte aiguilles, micro porte aiguilles
Portaghi, micro porta aghi

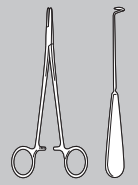

TC GOLD

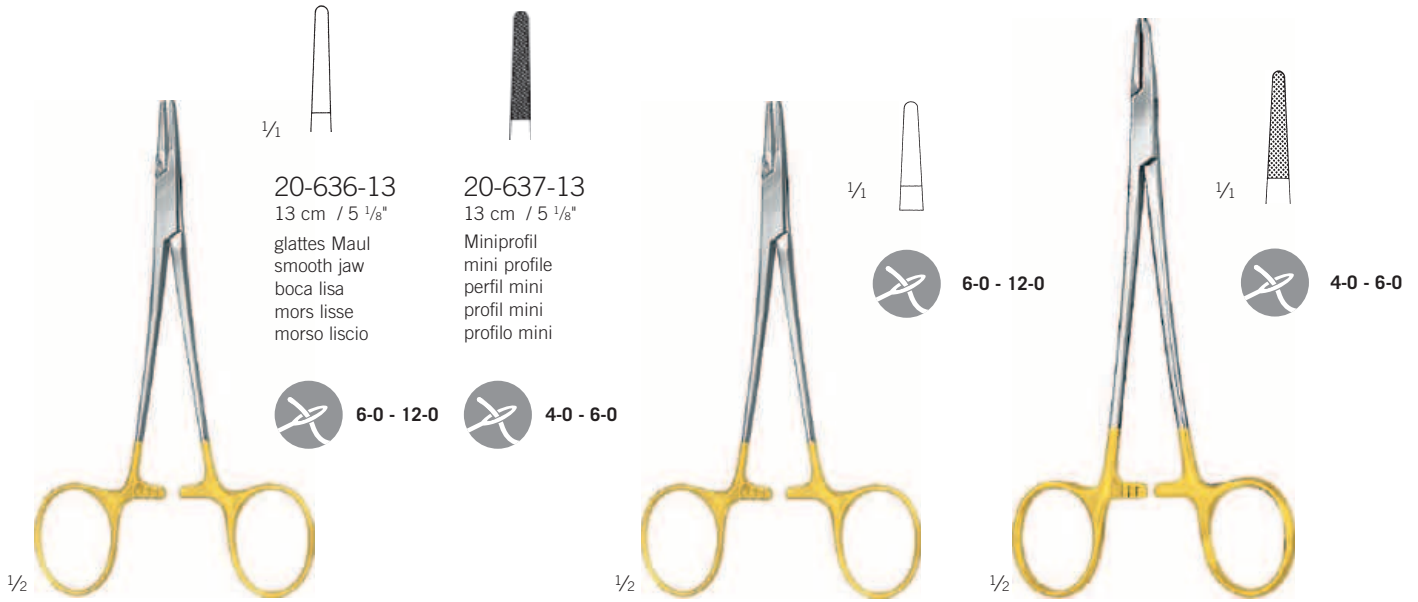

Halsey
20-636-13 - 20-637-13

Webster
20-637-12

Crile-Wood
20-638-15



Crile-Wood
20-638-20
20 cm / 7 7/8"
Miniprofil
mini profile
perfil mini
profil mini
profilo mini

Mayo-Hegar
20-642-16 - 20-642-30
Normalprofil
standard profile
perfil estándar
profil normal
profilo normale

Nadelhalter

Needle Holders

Porta-agujas

Porte-aiguilles

Portaghi

TC GOLD



1/1

20-646-18
18 cm / 7 1/8"



4-0 - 6-0



20-646-20
20 cm / 7 7/8"



4-0 - 6-0

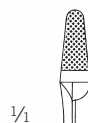
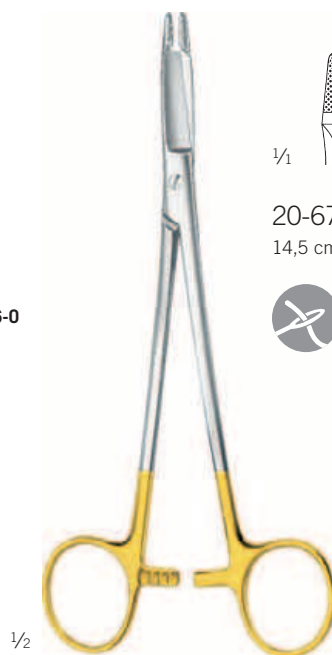

1/1

20-672-14
14,5 cm / 5 7/8"



0-6 - 4-0



20-672-17
17 cm / 6 5/8"



0-6 - 4-0



20-672-18
19 cm / 7 4/8"



0-6 - 4-0

De Bakey 20-646-18 - 20-646-31

schlankes Modell, Miniprofil
slender pattern, mini profile
modelo delgado, perfil mini
modèle gracileprofil mini
modello delicato, profilo mini

Olsen Hegar 20-672-14 - 20-672-18

Normalprofil
standard profile
perfil estándar
profil normal
profilo normale

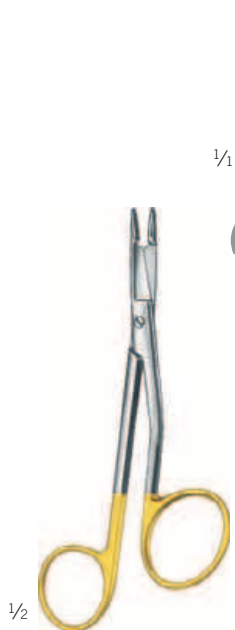

1/1



6-0 - 12-0

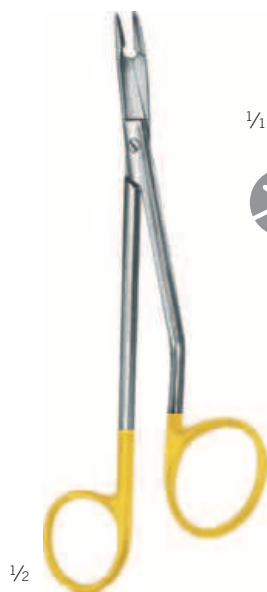

1/1



4-0 - 6-0



1/1



0-6 - 4-0

Foster-Gillies 20-673-12

11 cm / 4 3/8"
glattes Maul
smooth jaw
boca lisa
mors lisse
morso liscio

Gillies-Mini 20-673-15

15 cm / 5 7/8"
Miniprofil
mini profile
perfil mini
profil mini
profilo mini

Gillies 20-673-16

16 cm / 6 2/8"
Normalprofil
standard profile
perfil estándar
profil normal
profilo normale

Nadelhalter

Needle Holders

Porta-agujas

Porte-aiguilles

Portaghi

Nadelhalter, Mikro-Nadelhalter

Needle holders, micro needle holders

Porta agujas, micro porta agujas

Porte aiguilles, micro porte aiguilles

Portaghi, micro porta aghi

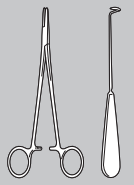

TC GOLD

	1/1	1/1	1/1		1/1	1/1	1/1
	20-674-14	20-674-17	20-674-20		20-676-14	20-676-17	20-676-20
	14 cm / 5 4/8"	17 cm / 6 6/8"	20 cm / 7 7/8"		14 cm / 5 4/8"	17 cm / 6 6/8"	20 cm / 7 7/8"
	0-6 - 4-0	0-6 - 4-0	0-6 - 4-0		0-6 - 4-0	0-6 - 4-0	0-6 - 4-0
1/2				1/2			

Mathieu
20-674-14 - 20-674-20

Normalprofil
standard profile
perfil estándar
profil normal
profilo normale

Mathieu
20-676-14 - 20-676-20

Normalprofil
standard profile
perfil estándar
profil normal
profilo normale

	1/1	1/1	1/1		1/1
	20-678-17	20-678-20	20-678-23		20-684-18
	17 cm / 6 6/8"	20 cm / 7 7/8"	23 cm / 9"		17 cm / 6 6/8"
	0-6 - 4-0	0-6 - 4-0	0-6 - 4-0		0-6 - 4-0
1/2				1/2	

Mathieu
20-678-17 - 20-678-23

Normalprofil, mit Innensperre
standard profile, with interior ratchet
perfil estándar, con cremallera interior
profil normal, avec crémaillère interne
profilo normale, con cremagliera interna

Toennis
20-684-18

Normalprofil
standard profile
perfil estándar
profil normal
profilo normale

Nadelhalter

Needle Holders

Porta-agujas

Porte-aiguilles

Portaghi

TC GOLD



1/1



0-6 - 4-0

1/2

Lichtenberg
20-686-20

20 cm / 7 7/8"

Normalprofil
standard profile
perfil estándar
profil normal
profilo normale



1/2

Langenbeck
20-692-18 - 20-692-23

Normalprofil
standard profile
perfil estándar
profil normal
profilo normale



1/1

20-692-18
18,5 cm / 7 3/8"



0-6 - 4-0



20-692-20
20,5 cm / 8 1/8"



0-6 - 4-0



20-692-23
23 cm / 9"



0-6 - 4-0



1/2

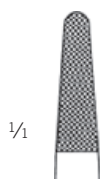

1/1

20-696-20
20,5 cm / 8 1/8"



0-6 - 4-0



20-696-23
23 cm / 9"



0-6 - 4-0

Zweifel
20-696-20 - 20-696-23

mit Klappsperre, Normalprofil
with hinged ratchet, standard profile
con cremallera abatible, perfil estándar
avec crémaillère repliable, profil normal
con cremagliera a scatto, profilo normale

23

Meißel, Raspatorien

Chisels, periosteal elevators

Cinceles, periostótomos

Ciseaux burins, raspatoires

Scalpelli, periostotomi

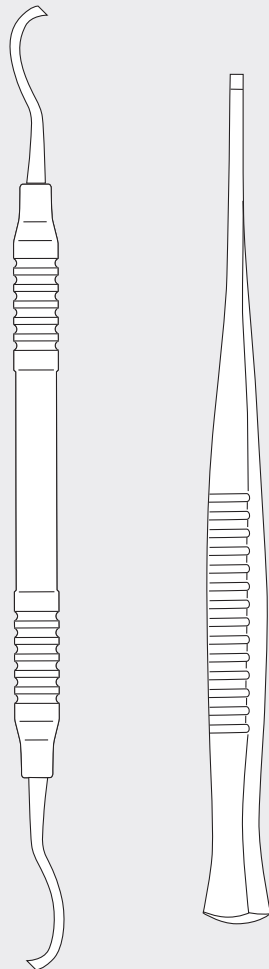

Flachmeißel

Chisels
Cinceles
Ciseaux burins
Scalpelli

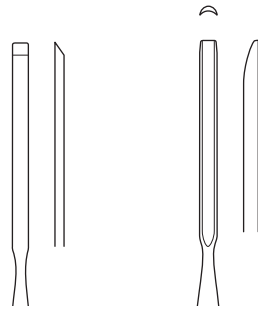

23-060-20

23-061-20



1/16



23-105-02
13,5 cm / 5 3/8"
2 mm



23-106-02
17 cm / 6 5/8"
2 mm



1/16

5 mm



23-060-30

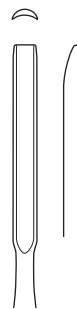

23-061-30



23-105-03
13,5 cm / 5 3/8"
3 mm



23-106-03
17 cm / 6 5/8"
3 mm



23-105-04
13,5 cm / 5 3/8"
4 mm



23-106-04
17 cm / 6 5/8"
4 mm



1/2

Iglhaut
38-800-05
17 cm / 6 5/8"



1/2

Buckley
23-060-20 - 23-061-40
16 cm / 6 1/8"

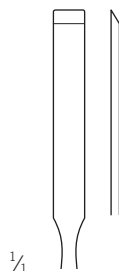

1/16

23-060-40

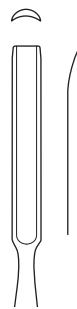

23-061-40



23-105-05
13,5 cm / 5 3/8"
5 mm



23-106-05
17 cm / 6 5/8"
5 mm



23-105-06
13,5 cm / 5 3/8"
6 mm



23-106-06
17 cm / 6 5/8"
6 mm



1/2

Partsch
23-105-02 - 23-106-06



Hohlmeißel, Osteotome



Gouges, osteotomes
 Gubias, osteótomos
 Gouges, ostéotomes
 Sgorbie, osteotomi

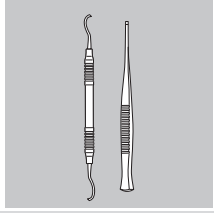

Meißel, Raspatorien



Chisels, periosteal elevators
 Cinceles, periostótomos
 Ciseaux burins, raspatoires
 Scalpelli, periostotomi







1/1  
23-109-02 **23-110-02**
 13,5 cm / 5 3/8" 16,5 cm / 6 4/8"
2 mm **2 mm**



1/1  
23-132-04
4 mm



1/1  
23-133-04
4 mm



 
23-109-03 **23-110-03**
 13,5 cm / 5 3/8" 16,5 cm / 6 4/8"
3 mm **3 mm**



 
23-132-06
6 mm



 
23-133-06
6 mm



 
23-109-04 **23-110-04**
 13,5 cm / 5 3/8" 16,5 cm / 6 4/8"
4 mm **4 mm**



 
23-132-08
8 mm



 
23-133-08
8 mm



 
23-109-05 **23-110-05**
 13,5 cm / 5 3/8" 16,5 cm / 6 4/8"
5 mm **5 mm**

 
23-132-10
10 mm

 
23-133-10
10 mm

 
23-109-06 **23-110-06**
 13,5 cm / 5 3/8" 16,5 cm / 6 4/8"
6 mm **6 mm**

 
23-132-12
12 mm

 
23-133-12
12 mm



1/2
Partsch
 23-109-02 - 23-110-06



1/2
Lexer-Mini
 23-132-04 - 23-132-12
 18 cm / 7 1/8"



1/2
Lexer-Mini
 23-133-04 - 23-133-12
 18 cm / 7 1/8"



Osteotome

Osteotomes

Osteótomos

Ostéotomes

Osteotomi

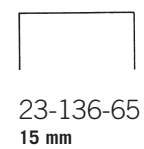
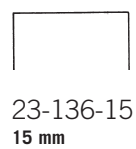
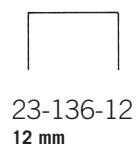
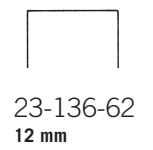
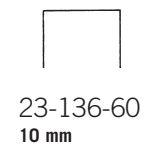
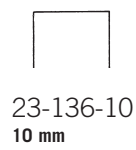
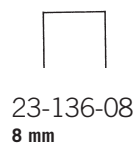
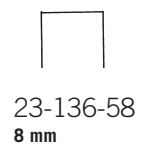
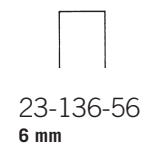
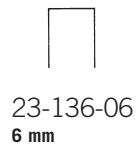
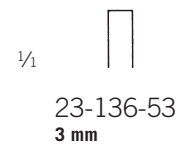
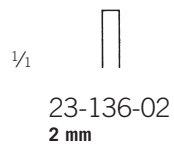

Lambotte-Mini
23-136-02 - 23-136-15
12,5 cm / 4 $\frac{7}{8}$ "



Lambotte-Mini
23-136-53 - 23-136-65
17 cm / 6 $\frac{6}{8}$ "

Stöbel

Tampers
Punzones metálicos
Pilons métalliques
Pestoni metallici

Meißel, Raspatorien

Chisels, periosteal elevators
Cinceles, periostótomos
Ciseaux burins, raspatoires
Scalpelli, periostotomi

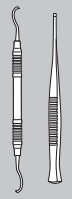

23-198-02 - 23-198-10
15,5 cm / 6 1/8"

Hämmer

Mallets
Martillos
Maillets
Martelli

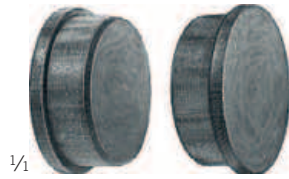

1/1

23-221-00

Ersatzbacken (Paar)
Spare Facings (pair)
Tapas de repuesto (par)
Plaques de rechange (paire)
Placche di ricambio (paio)



23-220-17

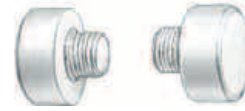

23-262-90

Ersatzbacken (Paar)
Spare Facings (pair)
Tapas de repuesto (par)
Plaques de rechange (paire)
Placche di ricambio (paio)



23-262-19



1/2

Williger
23-216-01
16,5 cm / 6 1/8"

Kopf	Gewicht
head	weight
cabeza	peso
tête	poids
testa	peso
Ø 20 mm	140 g



1/2

Mead
23-220-17
19 cm / 7 1/8"

mit austauschbaren Kunststoffbacken
with interchangeable plastic disks
con tapas intercambiables
avec plaques interchangeables
con placche intercambiabili

Kopf	Gewicht
head	weight
cabeza	peso
tête	poids
testa	peso
Ø 27 mm	300 g



1/2

23-262-19
19 cm / 7 1/8"



Kopf	Gewicht
head	weight
cabeza	peso
tête	poids
testa	peso
Ø 25 mm	300 g



1/2

Herbert
23-264-19
19 cm / 7 1/8"

für Ulnakopfprothesen
for ulna head prosthesis
para prótesis de la cabeza ulnar
pour prothèse de la tête ulnaire
protesi per la testa ulnare



Kopf	Kopf
head	head
cabeza	cabeza
tête	tête
testa	testa
Ø 25 mm	215 g

Scharfe Löffel

Bone curettes
Cucharillas cortantes
Curettes tranchantes
Curette taglienti

Meißel, Raspatorien

Chisels, periosteal elevators
Cinceles, periostótomos
Ciseaux burins, raspatoires
Scalpelli, periostotomi

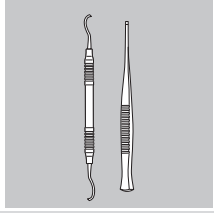

Fig. 0
23-280-10



Fig. 0
23-304-10



Fig. 00
23-308-10



Fig. 00
23-280-20



Fig. 00
23-304-20



Fig. 00
23-308-20



Fig. 000
23-280-30



Fig. 000
23-304-30



Fig. 000
23-308-30



Fig. 0000
23-280-40



Fig. 0000
23-304-40



Fig. 0000
23-308-40



1/2

Volkmann
23-280-01 - 23-280-40

17 cm / 6 5/8"

oval
oval
ovalada
ovale
ovala



1/2

Volkmann
23-304-10 - 23-305-06

17 cm / 6 5/8"

oval, mit Hohlheft
oval, with hollow handle
ovalada, con mango hueco
ovale, avec manche creux
ovala, con manico vuoto



1/2

Bruns
23-308-10 - 23-309-06

17 cm / 6 5/8"

rund, mit Hohlheft
round, with hollow handle
redonda, con mango hueco
rond, avec manche creux
rotonda, con manico vuoto

Fz

23

Scharfe Doppellöffel, Periotome

Bone curettes, double ended, periotomes

Cucharillas de doble extremo, periótomos

Curettes doubles, periotomes

Curette doppie, periotomi

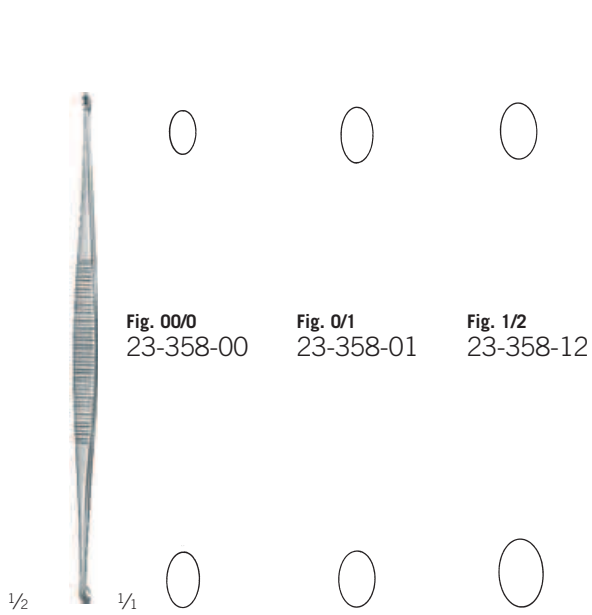

Fig. 00/0
23-358-00

Fig. 0/1
23-358-01

Fig. 1/2
23-358-12

Williger
23-358-00 - 23-358-12
14 cm / 5 4/8"

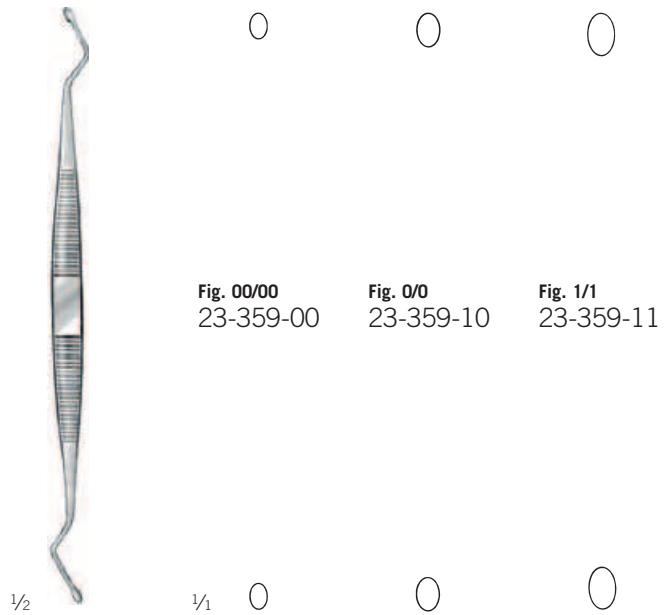
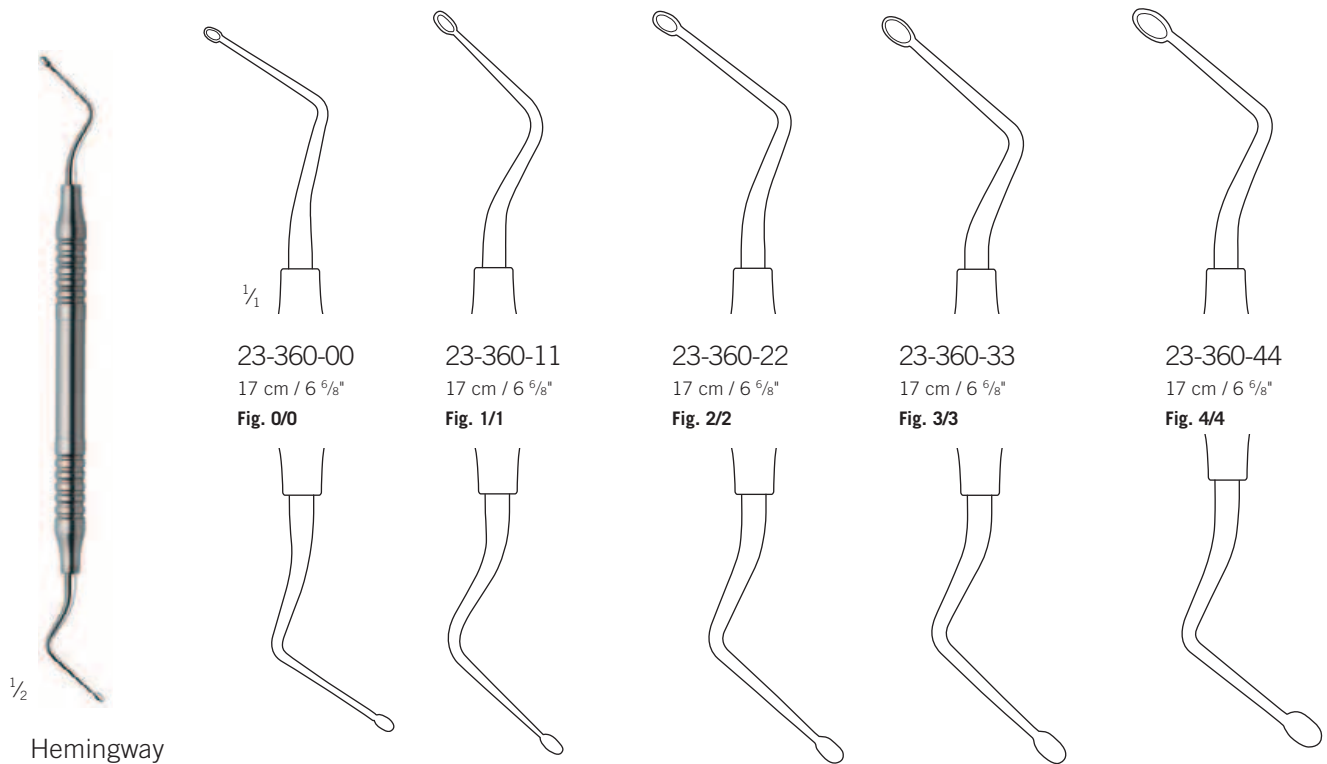

Fig. 00/00
23-359-00

Fig. 0/0
23-359-10

Fig. 1/1
23-359-11

Williger
23-359-00 - 23-359-11
16,5 cm / 6 4/8"



23-360-00
17 cm / 6 5/8"

Fig. 0/0

23-360-11
17 cm / 6 5/8"

Fig. 1/1

23-360-22
17 cm / 6 5/8"

Fig. 2/2

23-360-33
17 cm / 6 5/8"

Fig. 3/3

23-360-44
17 cm / 6 5/8"

Fig. 4/4

Hemingway
23-360-00 - 23-360-44

Periotome

Periotomes
Pperiótomos
Periotomes
Periotomi

Meißel, Raspatorien

Chisels, periosteal elevators
Cinceles, periostótomos
Ciseaux burins, raspatoires
Scalpelli, periostotomi

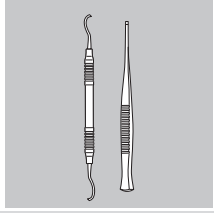

1/2

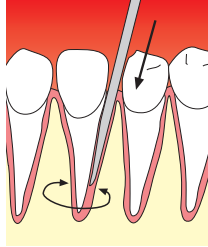

23-360-01
14 cm / 5 1/2"
Griff für Periotom-Ansätze
Handle for periotome tips
mango para periótomos
manche de pointes de périotomes
manico de periotomi

verdrehesicher
anti rotation
a prueba de torsión
antitorsion
antitorsione



1/4

23-360-02
gerade, schmal
straight, narrow
recta, estrecha
droit, étroit
diritto, sottile
No. 1



23-360-03
gerade, breit
straight, wide
recta, ancha
droit, large
diritto, largo
No. 2



23-360-04
gebogen, schmal
curved, narrow
curva, estrecha
courbé, étroit
arcuato, sottile
No. 1A



23-360-05
gebogen, breit
curved, wide
curva, ancha
courbé, large
arcuato, largo
No. 2A



1/4

23-360-06
abgewinkelt, schmal
angled, narrow
acodada, estrecha
coudé, étroit
angolato, sottile
No. 1B



23-360-07
abgewinkelt, breit
angled, wide
acodada, ancha
coudé, large
angolato, largo
No. 2B



Chirurgische Küretten

Bone curettes, double ended

Cucharillas de doble extremo

Curettes doubles

Curette doppie



1/2

Lucas-Martin

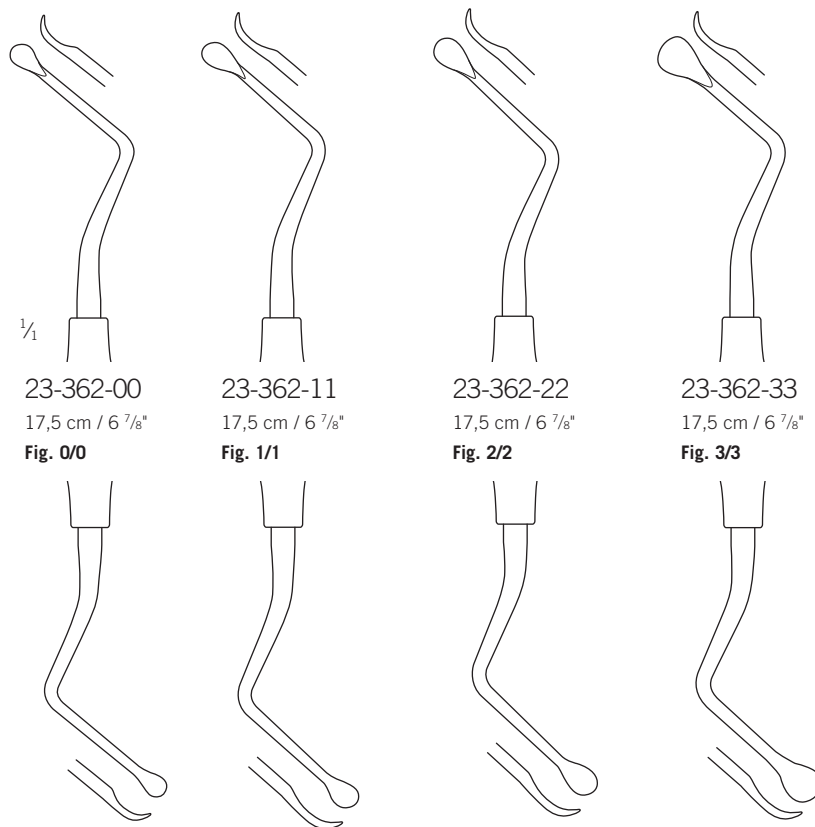

1/2

Miller-Colburn

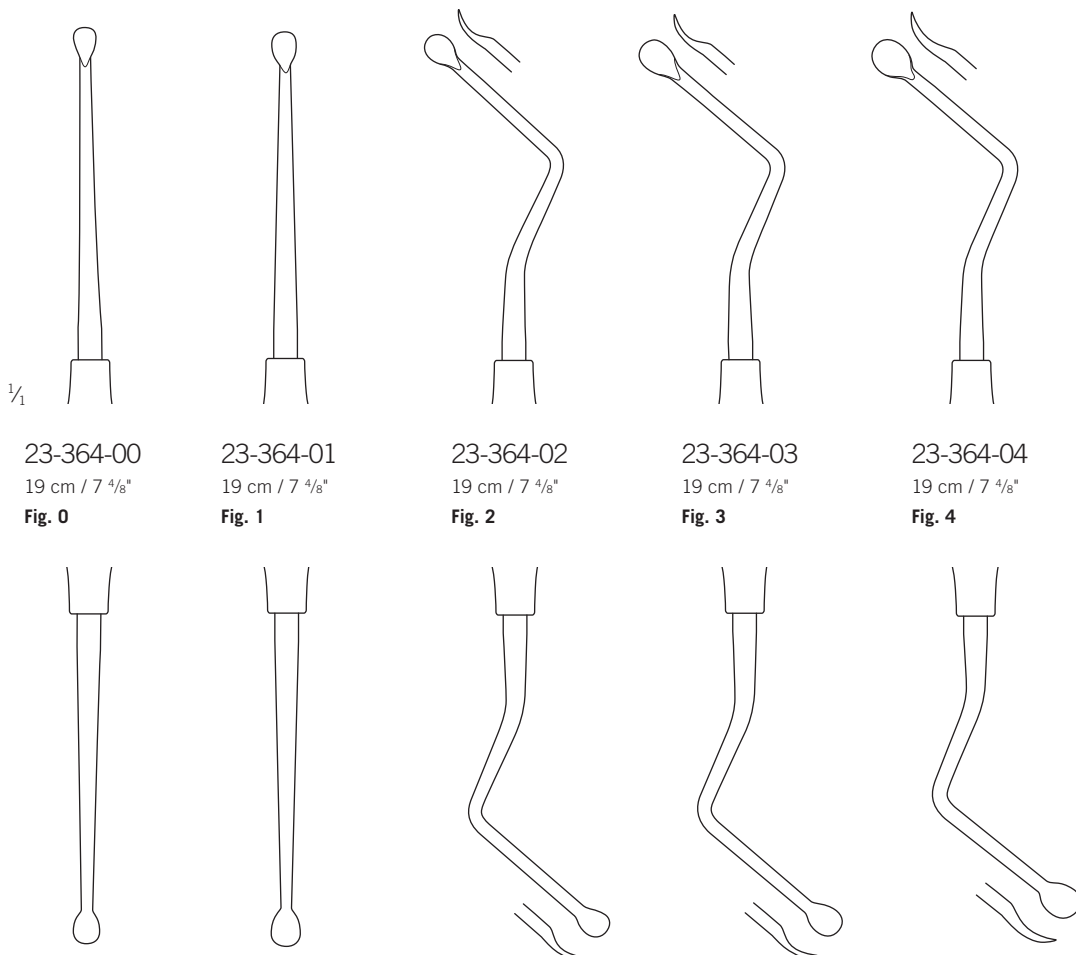

Scharfe Küretten, Chirurgische Küretten

Bone curettes, bone curettes, double ended
 Curetas cortantes, cucharillas de doble extremo
 Curettes, curettes doubles
 Curette, curette doppie

Meißel, Raspatorien

Chisels, periosteal elevators
 Cinceles, periostótomos
 Ciseaux burins, raspatoires
 Scalpelli, periostotomi

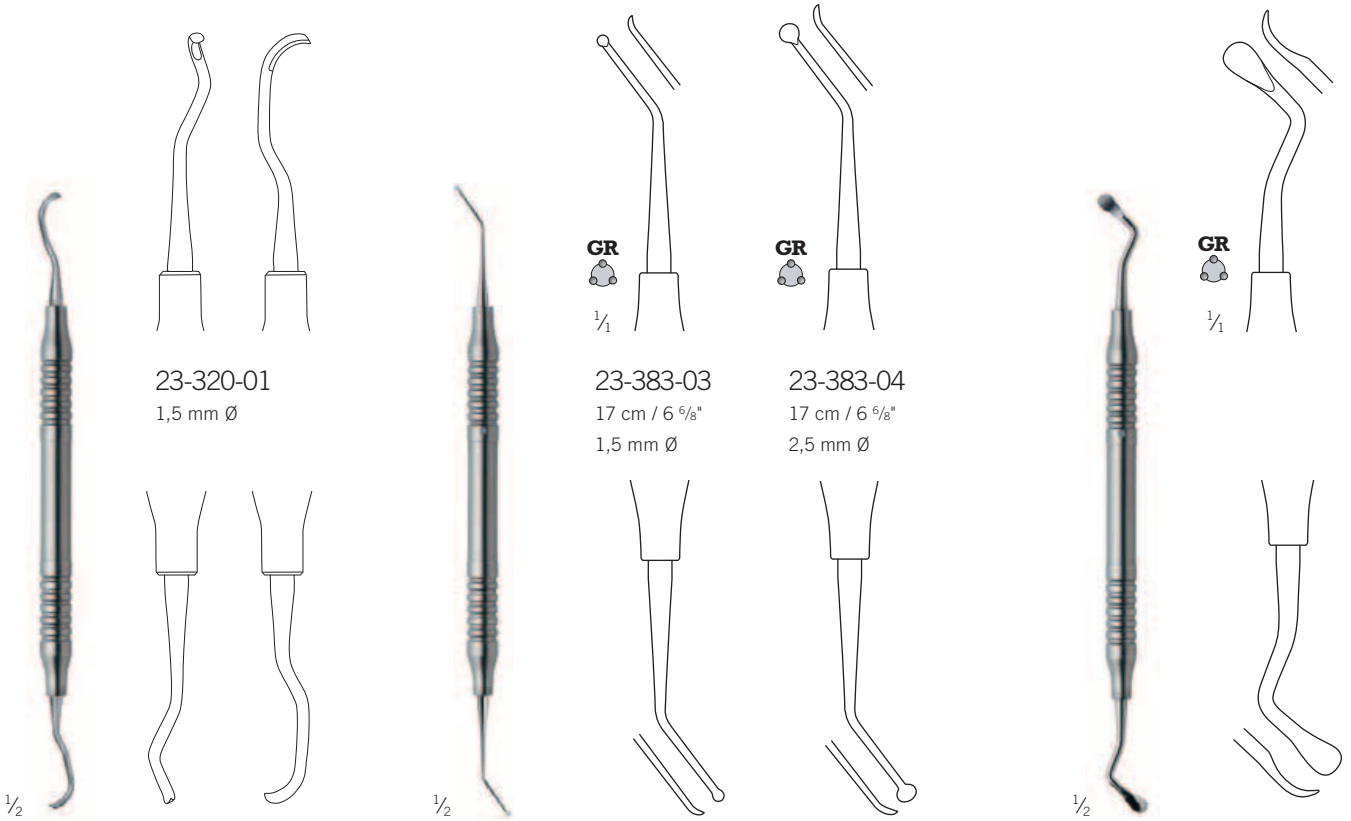
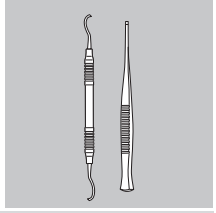

23-320-01
1,5 mm Ø

GR
1/1
23-383-03
17 cm / 6 6/8"
1,5 mm Ø

GR
23-383-04
17 cm / 6 6/8"
2,5 mm Ø

GR
1/1
23-395-21
17,5 cm / 6 7/8"

Iglhaut
 23-320-01
 17 cm / 6 3/4"
 Knochenkürette
 Bone curette
 Cucharilla p. ósea
 Curette pour os
 Curetta per osso



23-383-03 - 23-383-04
 Tellerkürette
 Plate type curette
 Cureta tipo plato
 Curette circulaire
 Curetta di tipo piatto

23-395-21
 17,5 cm / 6 7/8"

23

- | | | | | | | | |
|--|---|--|--|--|--|--|--|
| GR = grau
grey
gris
grigio | Y = gelb
yellow
amarillo
giallo | R = rot
red
rojo
rosso | G = grün
green
verde
verde | V = violett
violet
violeta
viola | W = weiß
white
blanco
bianco | B = blau
blue
azur
blu | N = schwarz
black
negro
nero |
|--|---|--|--|--|--|--|--|

Raspatorien

Periosteal elevators
 Periostótomos, legbras
 Rugines raspatoires, rugines
 Periostotomi

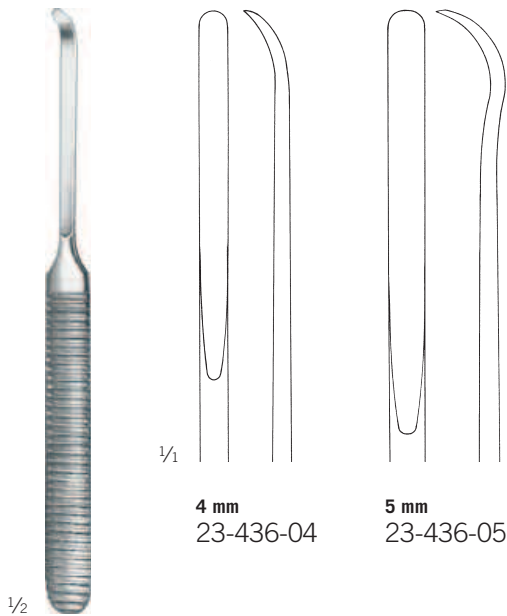

Kahre-Williger
 23-436-04 - 23-436-05

16,5 cm / 6 4/8"
 massiv
 solid
 macizo
 solide
 pieno

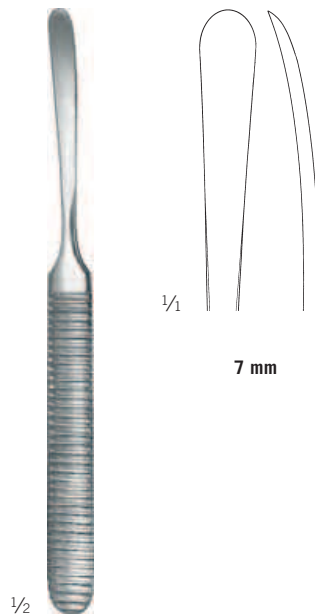

Williger
 23-436-07

16 cm / 6 4/8"
 massiv
 solid
 macizo
 solide
 pieno

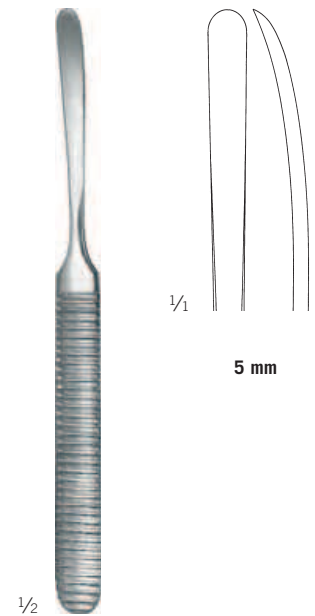

Williger
 23-436-16

16 cm / 6 4/8"
 massiv
 solid
 macizo
 solide
 pieno



Prichard
 23-435-17 - 23-435-19

17 cm / 6 6/8"
 Mikro-Abhalter
 Micro retractor
 Micro separador
 Micro rétracteur
 Micro divaricatore

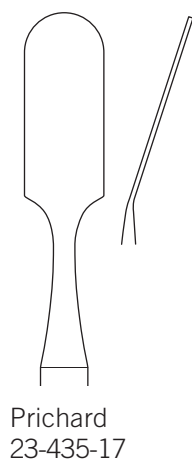

Prichard
 23-435-17

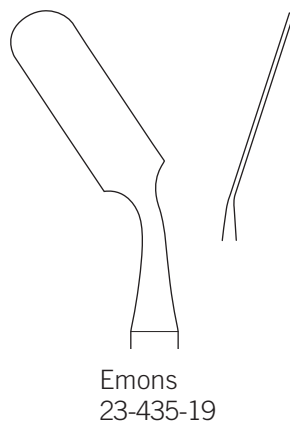

Emons
 23-435-19

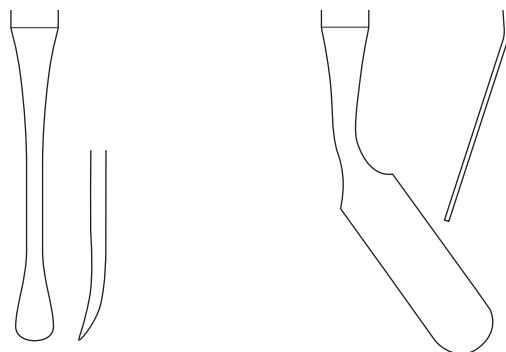

Raspatorien

Periosteal elevators
 Periostótomos, legras
 Rugines raspatoires, rugines
 Periostotomi

Meißel, Raspatorien

Chisels, periosteal elevators
 Cinceles, periostótomos
 Ciseaux burins, raspatoires
 Scalpelli, periostotomi

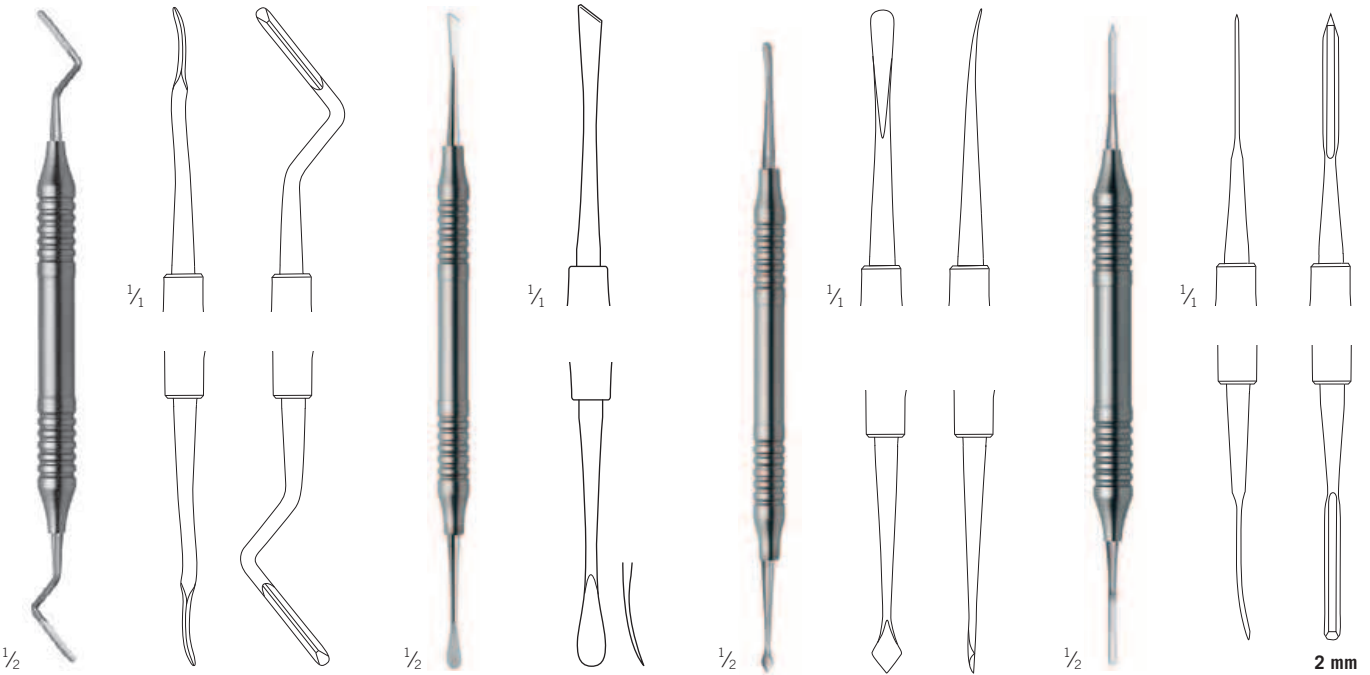
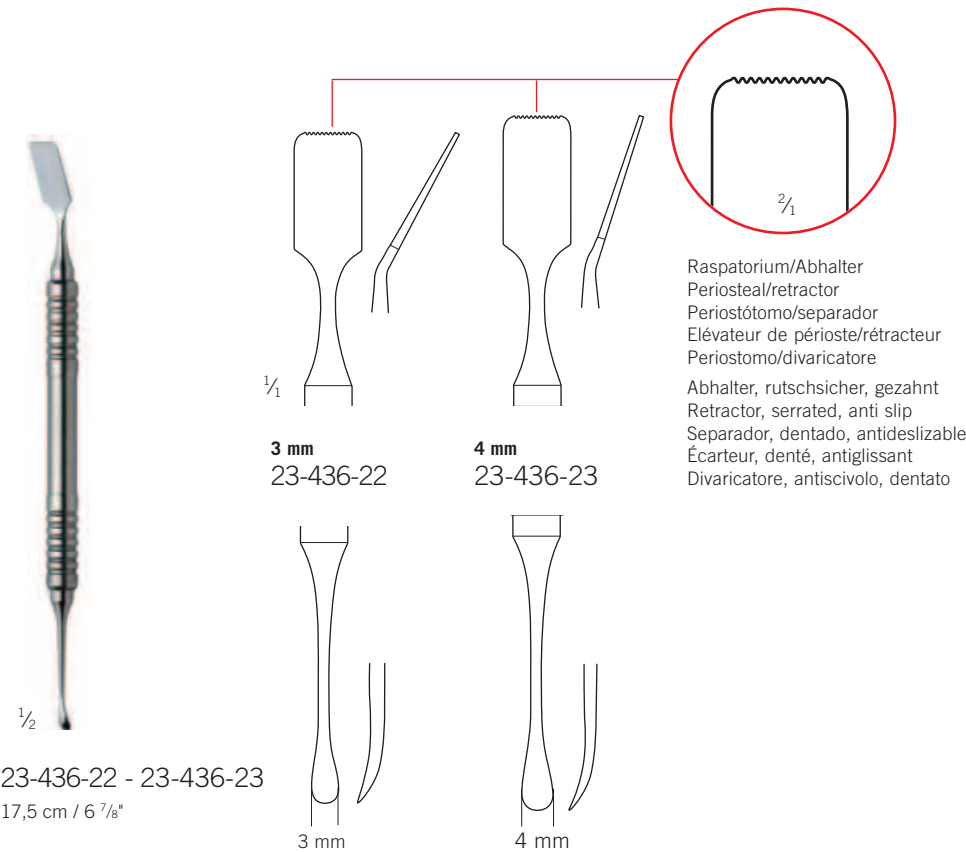
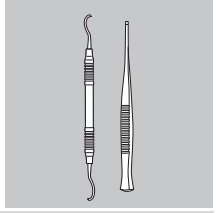

Iglhaut
 38-050-02 
 18 cm / 7 1/8"
 Tunnelinstrument
 Tunnelinstrument
 Instrument p. tunnel
 Instrument p. tunnel
 Strumento p. traforo

West
 23-446-18
 18 cm / 7 1/8"

Iglhaut
 23-402-18 
 18 cm / 7 1/8"
 Micro-Raspatorium
 Periosteal elevator
 Periostótomo
 Raspatoire
 Scollatore

Allen-Iglhaut
 38-050-01 
 18 cm / 7 1/8"
 Raspatorium
 Periosteal elevator
 Periostótomo
 Raspatoire
 Scollatore

Raspatorien

Periosteal elevators
 Periostótomos, legras
 Rugines raspatoires, rugines
 Periostotomi



1/2

Körner/Westermann
 23-448-01 - 23-448-02

18 cm / 7 1/8"

Mini-Dissektor / Gewebepusher
 zur atraumatischen Aktivierung der Interdentalspapille

Mini dissector / tissue pusher
 for atraumatic activation of interdental papilla

Mini disector / separador de tejido
 para la activación atraumática de la papila interdental

Instrument de dissection mini / séparateur de tissu
 pour l'activation atraumatique de la papille interdentaire

Strumento per dissezione mini / separatore di tessuto
 per l'attivazione atraumatica della papilla interdental

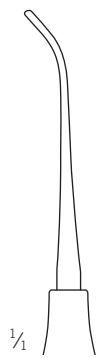

1/4

23-448-01 Ti

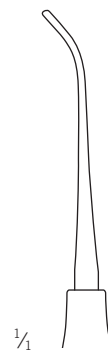

1/4

23-448-02 St
 18 cm / 7 1/8"



Raspatorium 2 mm breit
 Periosteal elevator 2 mm wide
 Periostótomo, ancho 2 mm
 Raspatoire 2 mm de large
 Periostotomo larghezza 2 mm

Gewebepusher Ø 1,1 mm
 Tissue pusher Ø 1.1 mm
 Separador de tejido Ø 1,1 mm
 Écarteur de tissu Ø 1,1 mm
 Separatore di tessuto Ø 1.1 mm

Raspatorium 2 mm breit
 Periosteal elevator 2 mm wide
 Periostótomo, ancho 2 mm
 Raspatoire 2 mm de large
 Periostotomo larghezza 2 mm

Gewebepusher Ø 1,1 mm
 Tissue pusher Ø 1.1 mm
 Separador de tejido Ø 1,1 mm
 Écarteur de tissu Ø 1,1 mm
 Separatore di tessuto Ø 1.1 mm

Raspatorien

Periosteal elevators
Periostótomos, legras
Rugines raspatoires, rugines
Periostotomi

Meißel, Raspatorien

Chisels, periosteal elevators
Cinceles, periostótomos
Ciseaux burins, raspatoires
Scalpelli, periostotomi



1/2

Freer

23-400-18

18,5 cm / 7 1/4"

Septumeelevator / Dentalhandgriff Dr. Wörtche
Septum elevator / Handle Dr. Wörtche
Elevador / Mango Dr. Wörtche
Elevateur / Manche Dr. Wörtche
Elevatore / Manico Dr. Wörtche



1/4

23-448-11

1/2

Körner/Westermann

23-448-11

16,5 cm / 6 4/8"

Raspatorium / Spiegelaufnahme
zur Gewebeaktivierung und palatinaler Sichtkontrolle

Periosteal / mirror end
for tissue activation and palatine visual control

Periostótomo / extremo para espejo
para la activación del tejido y el control visual del palatino

Elévateur de périoste / extrémité de miroir
pour l'activation des tissus et le contrôle visuel du palais

Periostotomo / estremità a specchio
per l'attivazione del tessuto e l'ispezione visiva del palatino



Mundspiegel Seite 287
Mouth mirrors page 287
Espejos de boca página 287
Miroirs à bouche page 287
Specchietti pagina 287

Raspatorien

Periosteal elevators
Periostótomos, legras
Rugines raspatoires, rugines
Periostotomi

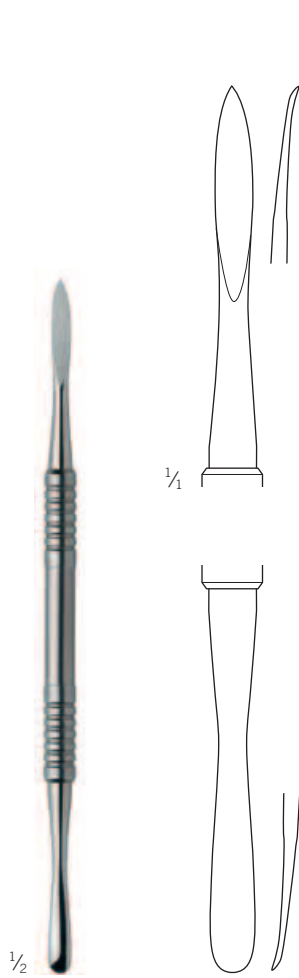

Ohl
23-449-18
18 cm / 7 1/8"

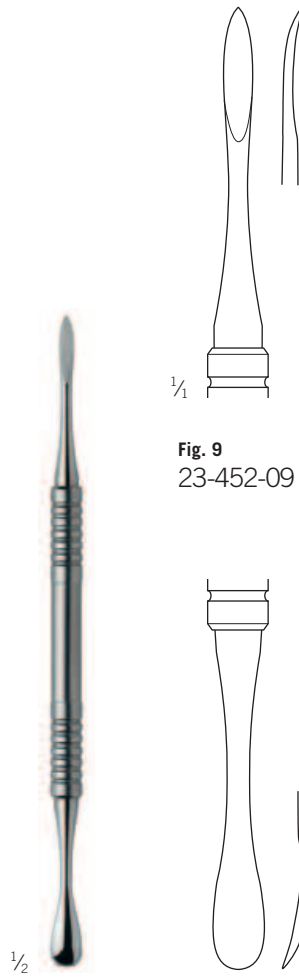

Molt
23-452-09
18 cm / 7 1/8"

Fig. 9
23-452-09

Raspatorien

Periosteal elevators
 Periostótomos, legras
 Rugines raspatoires, rugines
 Periostotomi

Meißel, Raspatorien

Chisels, periosteal elevators
 Cinceles, periostótomos
 Ciseaux burins, raspatoires
 Scalpelli, periostotomi

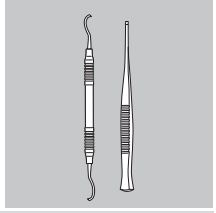

$\frac{1}{2}$

Fig. 851
23-452-51

Fig. 854
23-452-54

$\frac{1}{2}$

Molt
23-452-51 - 23-452-54
18 cm / 7 1/8"

$\frac{1}{2}$

Alijberg
23-454-19
18 cm / 7 1/8"

Alley
23-454-20
20 cm / 7 7/8"

$\frac{1}{2}$

23-454-19 - 23-454-20

Knochenfeilen

Bone files
 Limas para huesos
 Limes à os
 Lime per ossa

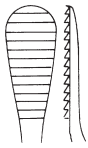

Fig. 1
 23-490-01
 18 cm / 7 1/8"

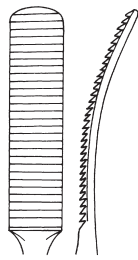

Fig. 2
 23-490-02
 18 cm / 7 1/8"

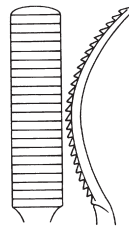

Fig. 3
 23-490-03
 18 cm / 7 1/8"

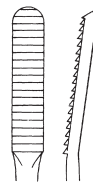

Fig. 4
 23-490-04
 18 cm / 7 1/8"

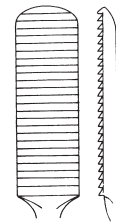
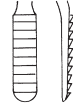
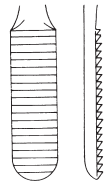
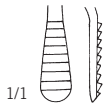

Fig. 5
 23-490-05
 18 cm / 7 1/8"

1/2

1/1



Miller-Colburn

23-490-01 - 23-490-05

18 cm / 7 1/8"

auf Zug schneidend
 downwards cutting
 corte abajo
 tranchant en bas
 tagliente in basso

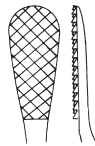
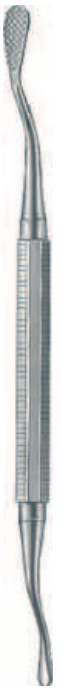

Fig. 1
 23-491-01
 18 cm / 7 1/8"

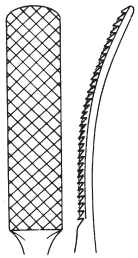

Fig. 2
 23-491-02
 18 cm / 7 1/8"

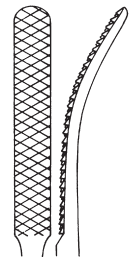

Fig. 3
 23-491-03
 18 cm / 7 1/8"

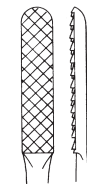
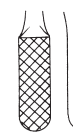
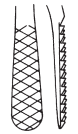
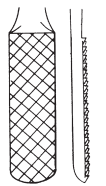
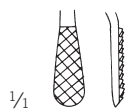

Fig. 4
 23-491-04
 18 cm / 7 1/8"

1/2

1/1



Miller-Colburn

23-491-01 - 23-491-04

18 cm / 7 1/8"

Kreuzhieb
 cross cut
 picado en cruz
 taille croisée
 tagliente a croce

Alveotomiefeilen, Elevatorien, Raspatorien

Alveotomy files, elevators, periosteal elevators

Limas para alveolotomía, elevadores, periostótomos

Limes pour alvéolotomie, élévateurs, rugines raspatoires

Lime per alveolotomia, elevatori, periostotomi

Meißel, Raspatorien

Chisels, periosteal elevators

Cinceles, periostótomos

Ciseaux burins, raspatoires

Scalpelli, periostotomi

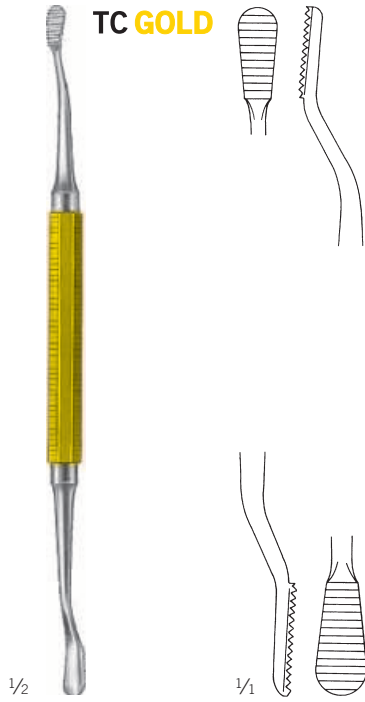
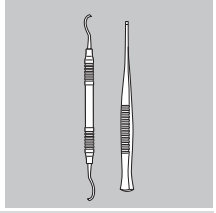

Miller
23-492-01
19 cm / 7 4/8"

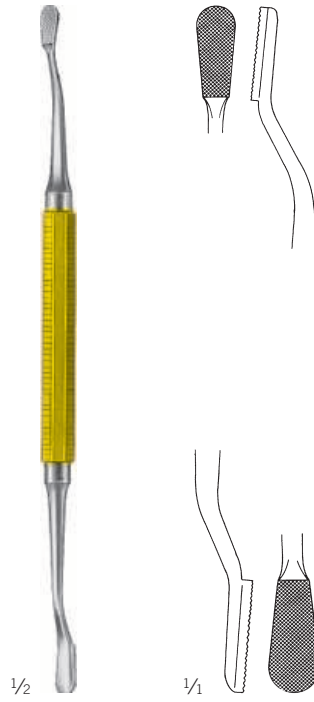

Miller
23-493-01
19 cm / 7 4/8"

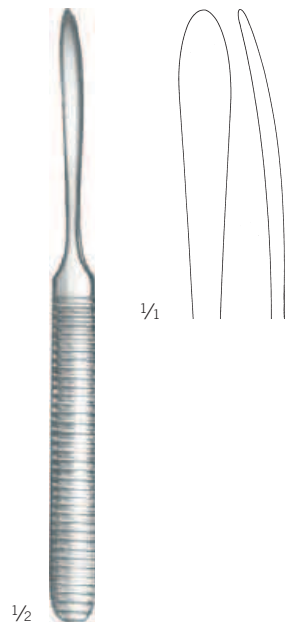

Williger
23-510-17
17 cm / 6 5/8"
massiv
solid
macizo
solide
pieno
7 mm

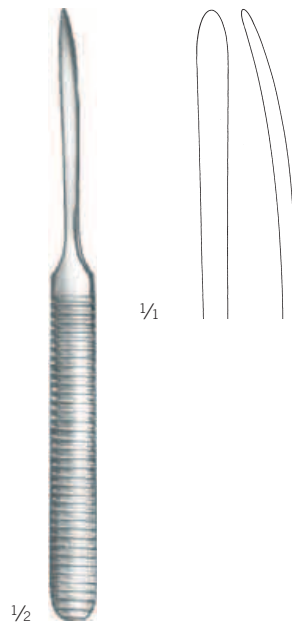

Williger
23-513-16
16 cm / 6 2/8"
massiv
solid
macizo
solide
pieno
4 mm

Hohlmeißelzangen

Bone rongeurs

Pinzas gubias

Pinces gouges

Pinze sgorbie

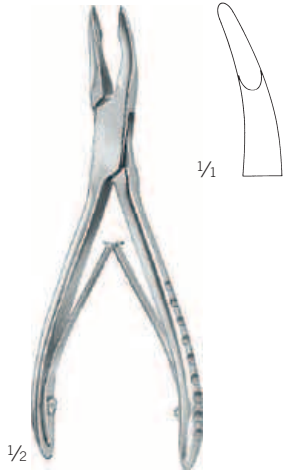

Friedmann
23-799-12
12,5 cm / 4 7/8"

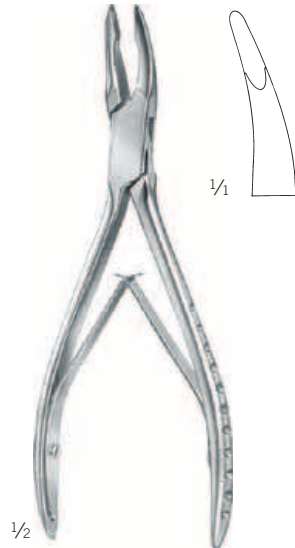

Friedmann
23-801-14
13,5 cm / 5 3/8"

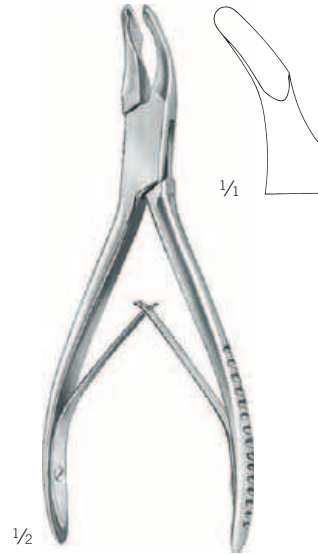

Cleveland
23-805-14
13,5 cm / 5 3/8"

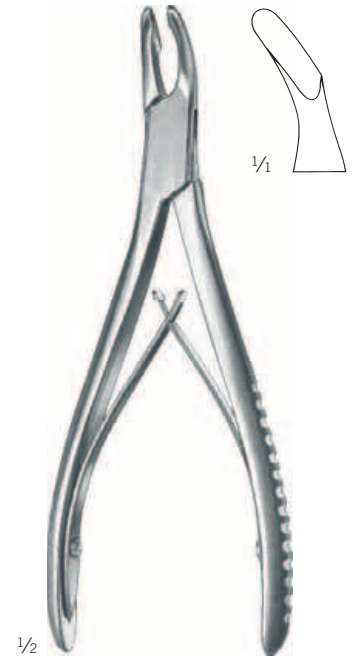

Cleveland
23-807-17
16,5 cm / 6 4/8"

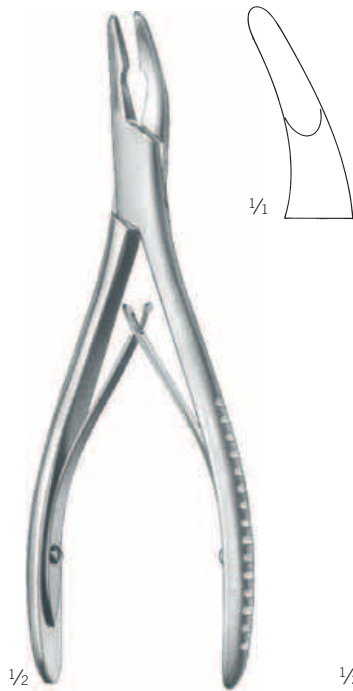

Hartmann
23-819-18
17,5 cm / 6 7/8"

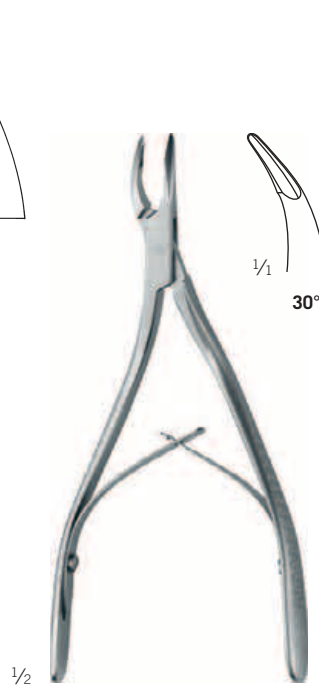

23-835-30
14,5 cm / 5 6/8"
S-Form
S-shape
forma S
courbé en S
curvo in forma S

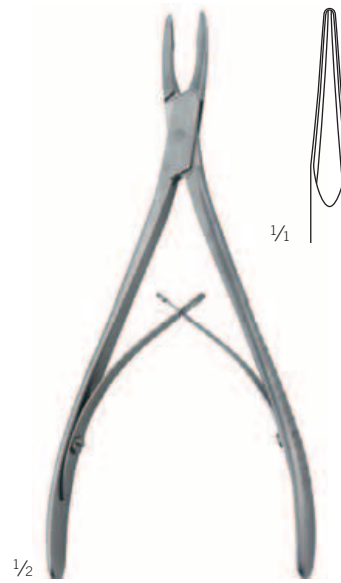

23-836-00
15,5 cm / 6 1/8"

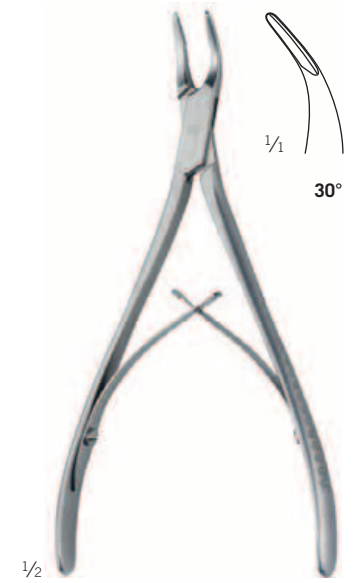

23-836-30
15,5 cm / 6 1/8"

Hohlmeißelzangen

Bone rongeurs
Pinzas gubias
Pincas gouges
Pinze sgorbie

Meißel, Raspatorien

Chisels, periosteal elevators
Cinceles, periostótomos
Ciseaux burins, raspatoires
Scalpelli, periostotomi

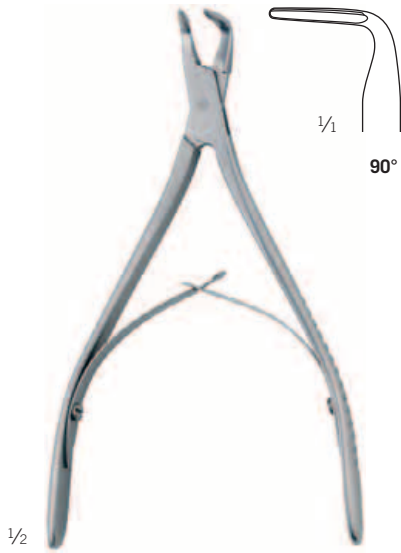
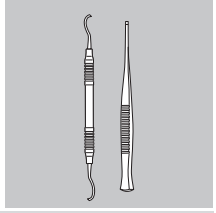

23-836-90
14,5 cm / 5 9/16"

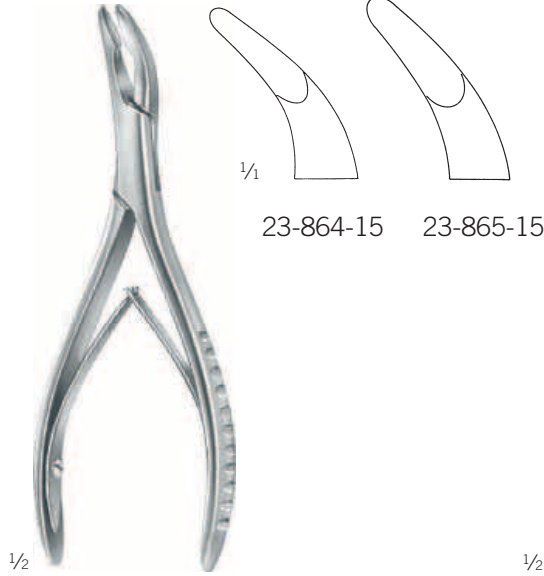

Luer
23-853-15 - 23-865-15
14,5 cm / 5 9/16"

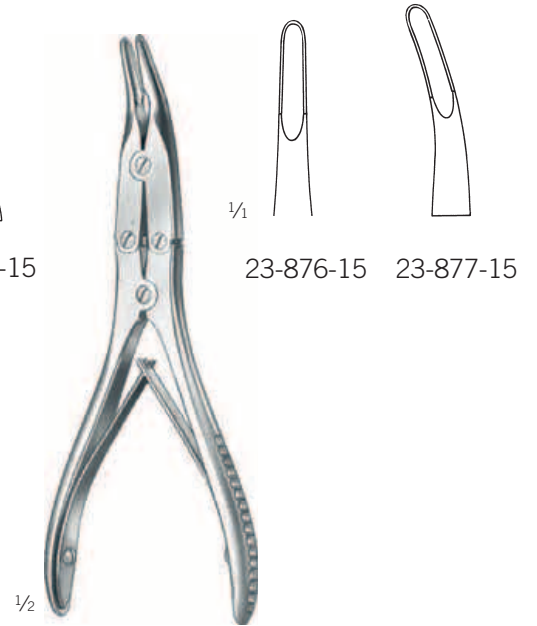

Böhler
23-876-15 - 23-877-15
15 cm / 5 7/8"

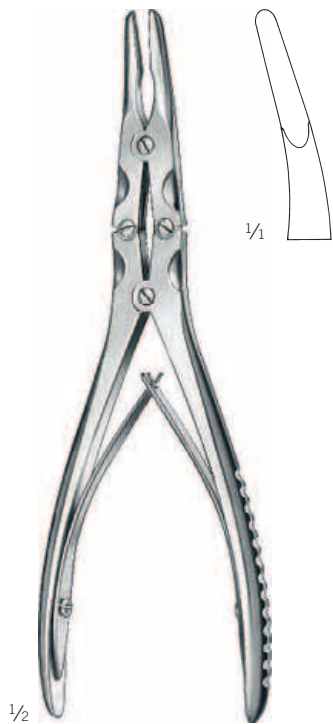

Beyer
23-879-18
18 cm / 7 1/8"



Mayfield
23-883-17
18 cm / 7 1/8"

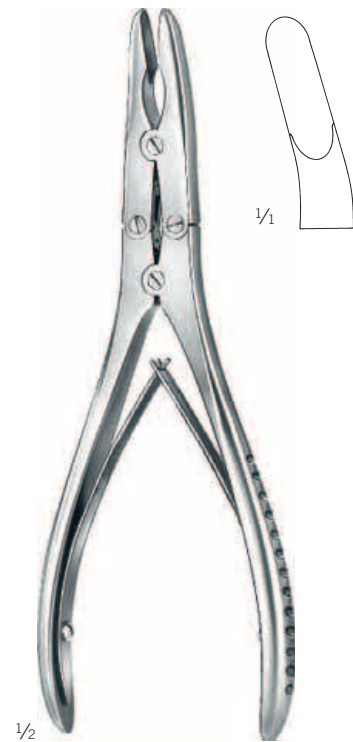

Ruskin
23-887-18
19 cm / 7 4/8"

Knochensplitterzangen

Bone cutting forceps
Pinzas cortantes para hueso
Pincas coupantes à os
Cesoie per ossa

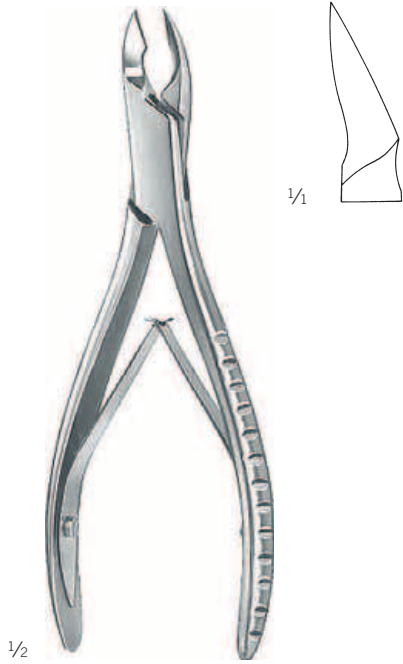

Cleveland
23-939-17
17 cm / 6 5/8"

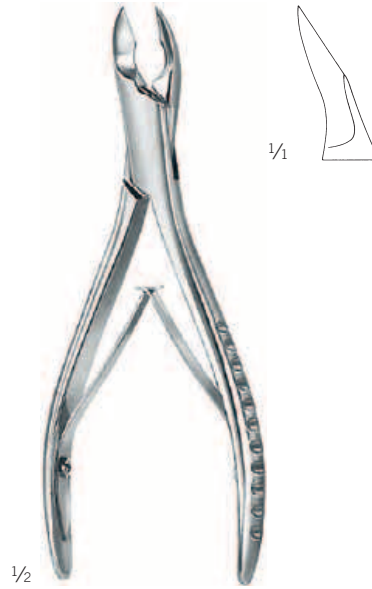

Cleveland
23-941-15
14,5 cm / 5 5/8"

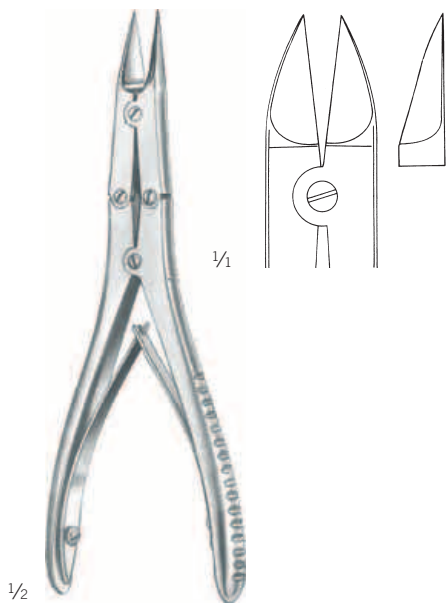

Böhler
23-944-15
14,5 cm / 5 5/8"

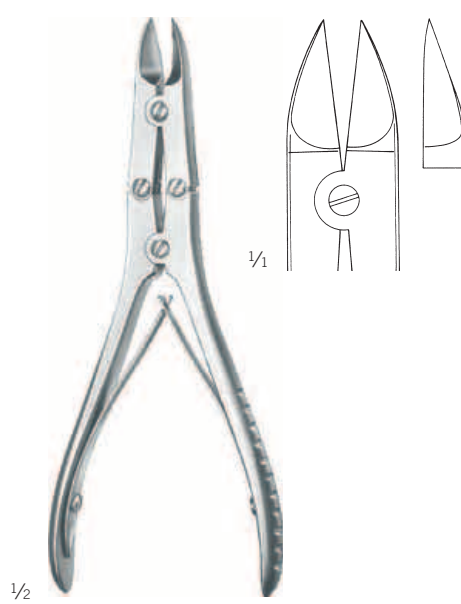

Böhler
23-946-15
14,5 cm / 5 5/8"

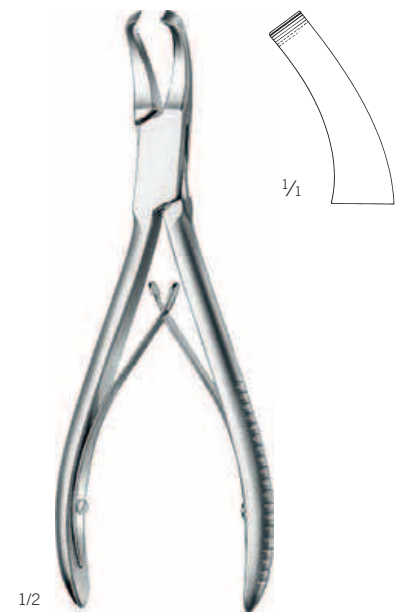

Cleveland
23-947-16
17 cm / 6 5/8"

Elevatorien

Elevators
Elevadores
Élévateurs
Elevatori

Meißel, Raspatorien

Chisels, periosteal elevators
Cinceles, periostótomos
Ciseaux burins, raspatoires
Scalpelli, periostotomi

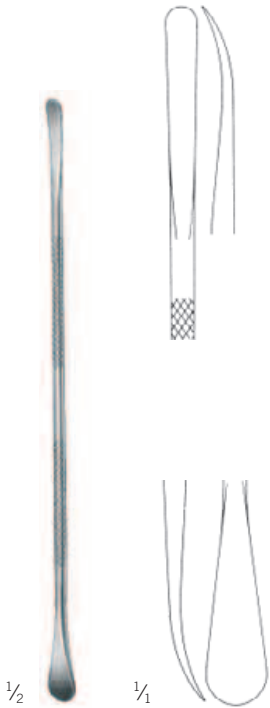
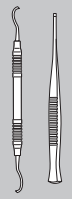

Terry
38-011-16

17 cm / 6 6/8"

zur Alveolarlappenabhebung
for elevation of alveolar flaps
para la elevación de las aletas alveolares
pour élévation du lambeau alvéolaire
per la elevazione del lembo alveolare

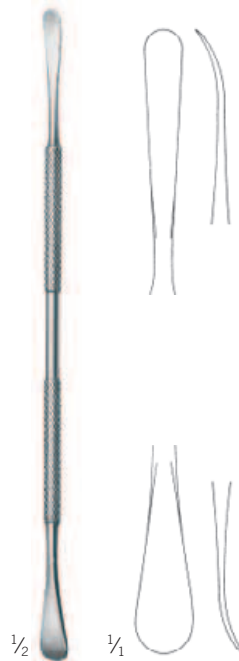

Terry
38-014-00

18 cm / 7 1/8"

für subperiostale Tunnel
for subperiosteal tunnels
para túneles subperiósticos
pour tunnel subpériostal
per tunnel superperiostale

Meißel, Raspatorien

Chisels, periosteal elevators

Cinceles, periostótomos

Burins, élévateurs du périoste

Scalpelli, leve periostali

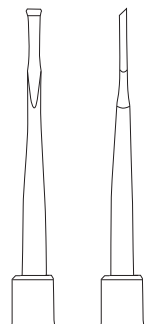

43-700-01

Fig. 1

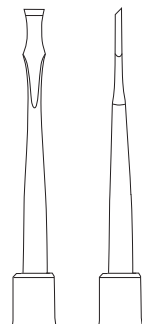

43-700-02

Fig. 2

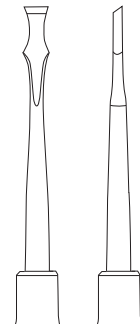

43-700-03

Fig. 3



1/2

Iglhaut
43-700-01 - 43-700-03



18 cm / 7 1/8"

für ziehende Bewegungen „Back Action“

for pull application “Back Action”

para movimientos extractores “Back Action”

pour mouvements de traction «Back Action»

per movimenti di trazione “Back Action”

Elevator, Raspatorium

Elevator, raspatory
 Elevador, legra
 Elévateur, rugine raspatoire
 Elevatore, elevatore periostale

Meißel, Raspatorien

Chisels, periosteal elevators
 Cinceles, periostótomos
 Ciseaux burins, raspatoires
 Scalpelli, periostotomi

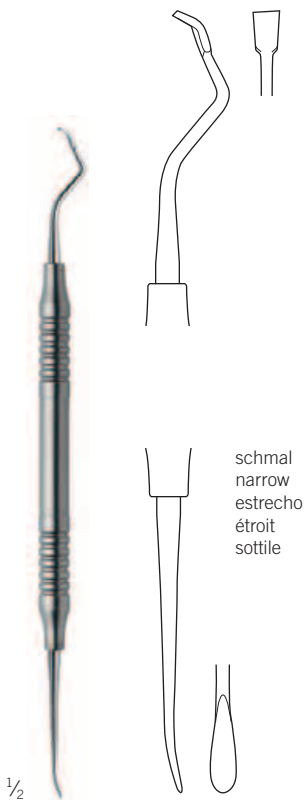
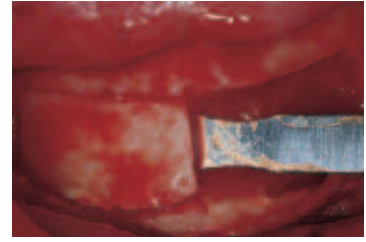
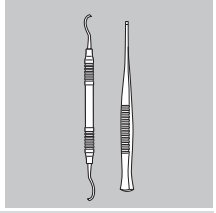

schmal
 narrow
 estrecho
 étroit
 sottile

1/2

43-883-16

für ziehende Bewegungen „Back Action“
 for pull application “Back Action”
 para movimientos extractores “Back Action”
 pour mouvements de traction «Back Action»
 per movimenti di trazione “Back Action”

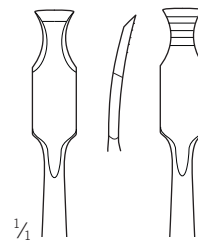
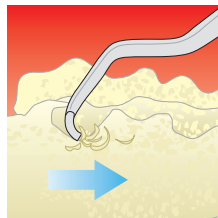

1/4

43-884-03

Fig. 1

modifiziert
 modified
 modificada
 modifiée
 modificata

aufwärts gebogen
 upwards curved
 curvos hacia arriba
 courbé vers le haut
 curvo verso l'alto

Rückseite graduert
 back side graduation
 parte de atrás graduada
 face arrière graduée
 lato posteriore graduato

1/2

Ochsenbein 43-884-03

Zur Entnahme von Transplantaten und Spongiosa
 for removing transplants and spongiosa
 para extraer trasplantes y la sustancia esponjosa
 pour prélever des transplants et du tissu spongieux
 per la rimozione dei trapianti e della materia spongiosa

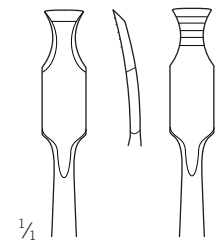

1/4

43-885-03

Fig. 2

modifiziert
 modified
 modificada
 modifiée
 modificata

abwärts gebogen
 downwards curved
 curvos hacia abajo
 courbé vers le bas
 curvo verso il basso

Rückseite graduert
 back side graduation
 parte de atrás graduada
 face arrière graduée
 lato posteriore graduato

1/2

Ochsenbein 43-885-03

23

Elevatorium, Raspatorium

Elevator, raspatory

Elevador, legra

Elévateur, rugine raspatoire

Elevatore, elevatore periostale



Obwegeser
48-135-21
21 cm / 8 2/8"



Obwegeser
48-137-21
21 cm / 8 2/8"

24

Hauthäkchen

Skin hooklets
Ganchitos para piel
Erignes cutanées
Uncini cutanei

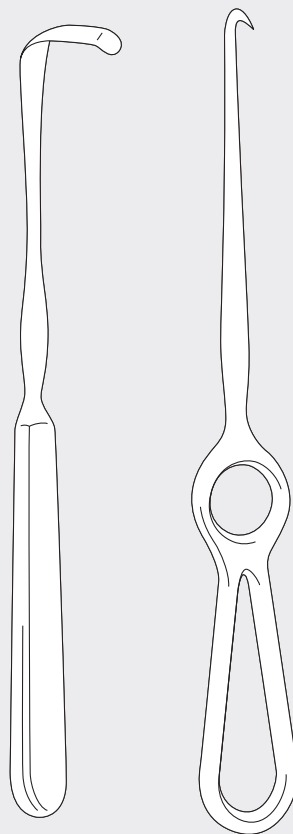

Durahaken, Hauthäkchen

Dura hooks, skin hooklets

Ganchos para duramadre, ganchitos para piel

Crochets pour dure mère, erignes cutanées

Uncini per dura madre, uncini cutanei

$\frac{1}{4}$?

28-203-15
14,5 cm / 5 $\frac{5}{8}$ "



$\frac{1}{2}$

Kilner
28-203-15
14,5 cm / 5 $\frac{5}{8}$ "
scharf
sharp
agudo
aiguë
aguzzo

$\frac{1}{4}$?

28-207-18
Fig. 1
kleine Biegung
small curvature
curva pequeña
courbure petite
curva piccola



$\frac{1}{2}$

Gillies
28-207-18 - 28-209-18
18 cm / 7 $\frac{1}{8}$ "
scharf
sharp
agudo
aiguë
aguzzo

$\frac{1}{4}$?

28-209-18
Fig. 2
große Biegung
large curvature
curva larga
courbure grande
curva grande

$\frac{1}{4}$?

scharf
sharp
afilado
affilé
acuminato



$\frac{1}{2}$

Joseph
37-684-15
15,5 cm / 6 $\frac{1}{8}$ "
Schleimhauthäkchen
Mucosa hooklet
Ganchito para la mucosa
Agrafe à muqueuse
Uncino per mucosa

Gewebefasszangen

Tissue grasping forceps
Pinzas para tejidos
Pincers pour tissus
Pinze per tessuti

Hauthäkchen

Skin hooklets
Ganchitos para piel
Erignes cutanées
Uncini cutanei

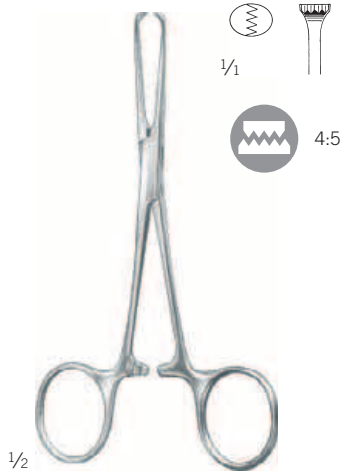
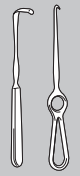

Allis-Baby
30-130-12
13 cm / 5 1/8"



Allis
30-132-15 - 30-134-25

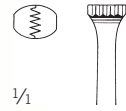

1/1
30-132-15
15,5 cm / 6 1/8"



4:5



5:6
30-134-15
15,5 cm / 6 1/8"



5:6



5:6
30-134-19
19 cm / 7 4/8"



5:6



5:6
30-134-25
25,5 cm / 10"



5:6

TC GOLD

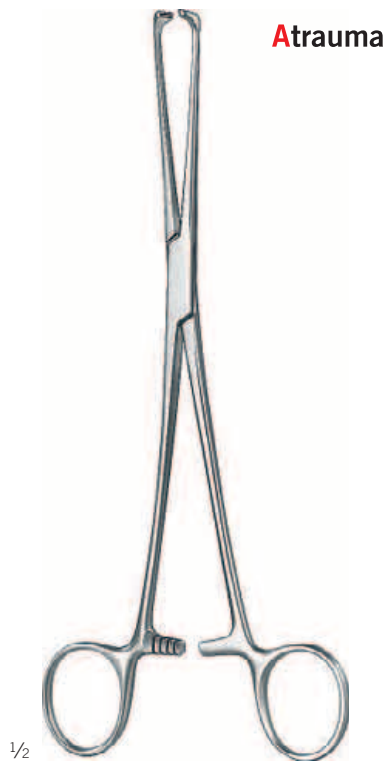

Atrauma



1/1
30-136-16
15,5 cm / 6 1/8"



1/1
30-136-20
20 cm / 7 7/8"



1/1

Babcock
30-190-16
16,5 cm / 6 4/8"

Gewebefasszangen

Tissue grasping forceps

Pinzas para tejidos

Pinces pour tissus

Pinze per tessuti

Atrauma

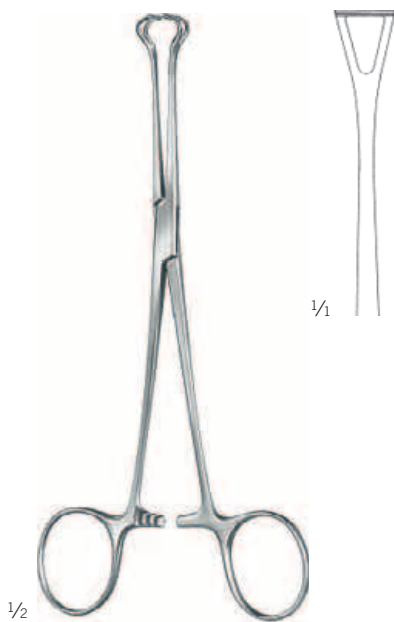

Babcock
30-192-16
15,5 cm / 6"

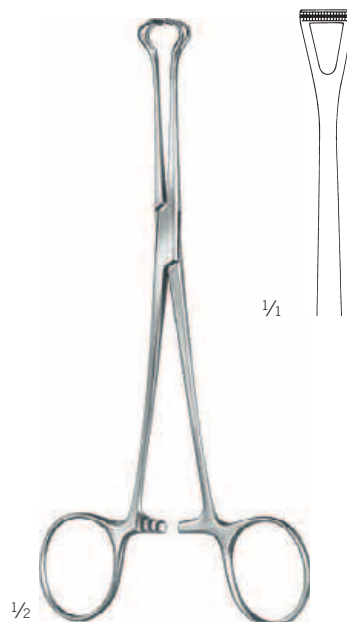

Babcock
30-196-16
16 cm / 6 2/8"

35

Knopfsonden

Probes

Sondas abotonadas

Sondes boutonnées

Sonde a bottone

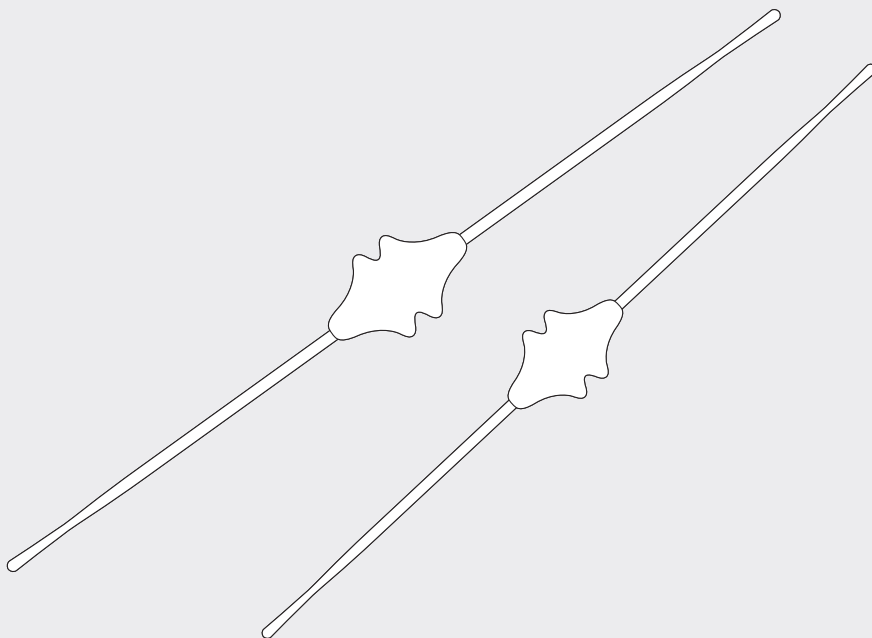

Knopfsonden

Probes

Sondas abotonadas

Sondes boutonnées

Sonde a bottone

GS



Fig.	
00 / 0	35-224-00
0 / 1	35-224-01
1 / 2	35-224-12
2 / 3	35-224-23
3 / 4	35-224-34
4 / 5	35-224-45
6 / 7	35-224-56
7 / 8	35-224-78

1/1

Bowman
35-224-00 - 35-224-78
13 cm / 5 1/8"

GS



Fig.	
00 / 0	35-226-00
0 / 1	35-226-01
1 / 2	35-226-12
2 / 3	35-226-23
3 / 4	35-226-34
4 / 5	35-226-45
6 / 7	35-226-56
7 / 8	35-226-78

1/1

Bowman
35-226-00 - 35-226-78
13 cm / 5 1/8"

38

Knocheninstrumente

Bone instruments
Instrumentos para hueso
Instruments à l'os
Strumenti per osso

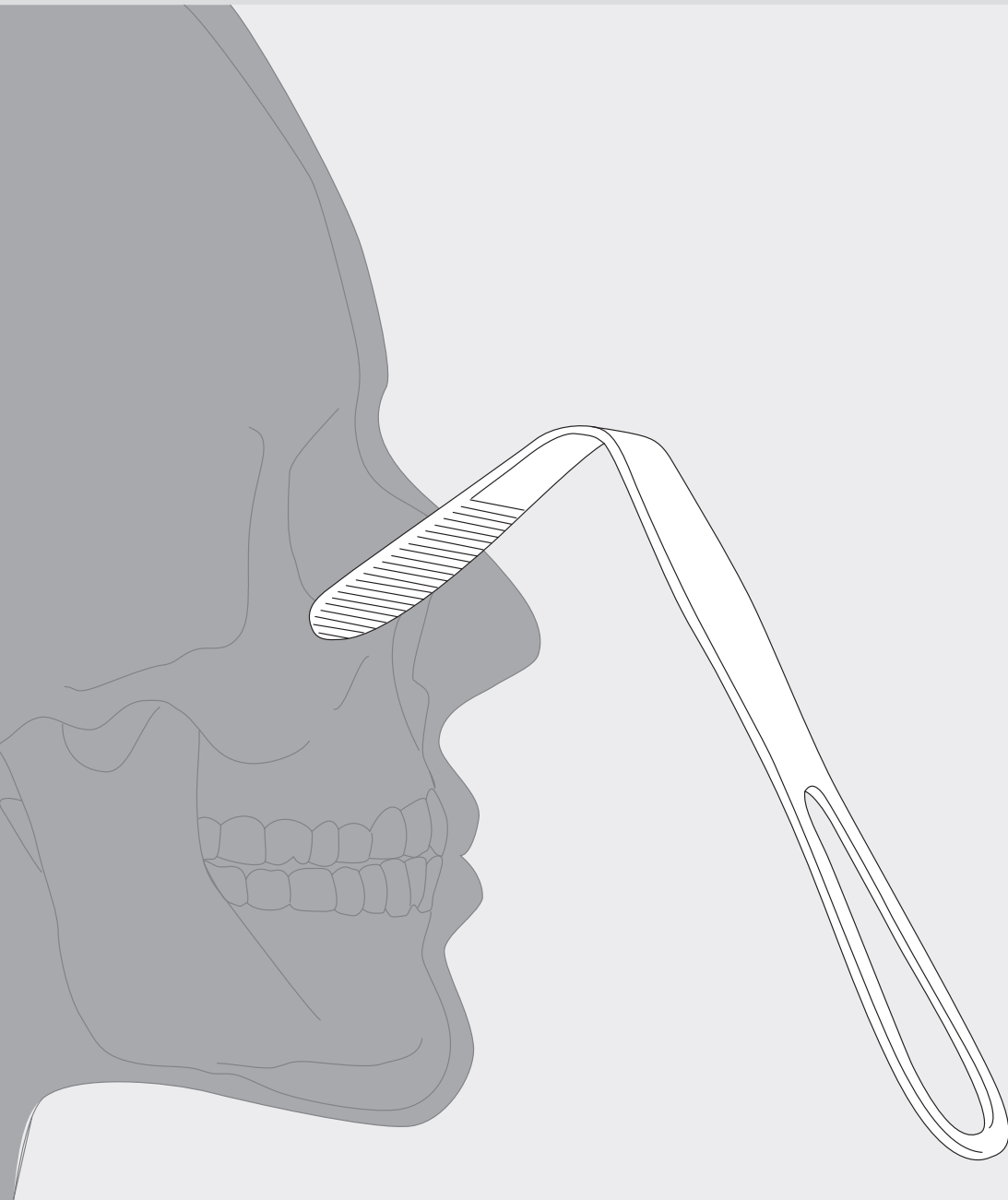

Sinus-Lift-Küretten

Sinus lift curettes

Curetas para sinus lift

Curettes pour sinus lift

Curette per sinus lift

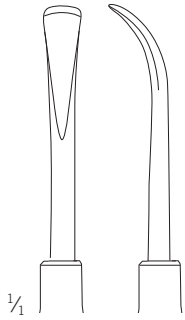

38-030-18

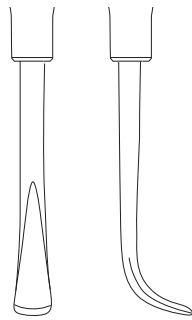

1/4

Iglhaut
38-030-18
18 cm / 7 1/8"

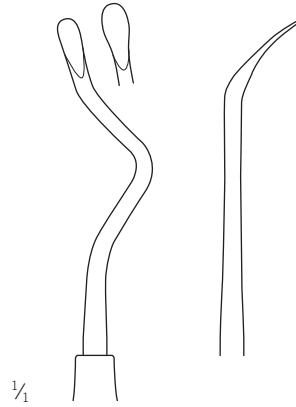
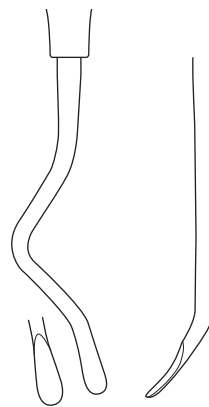

Fig. 1
38-017-01
19 cm / 7 4/8"



1/4

Körner-Westermann
38-017-01 - 38-017-05

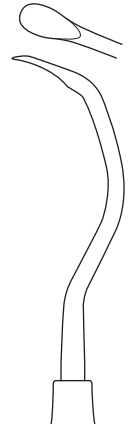

Fig. 2
38-017-02
20 cm / 7 7/8"



Sinus-Lift-Küretten

Sinus lift curettes
Curetas para sinus lift
Curettes pour sinus lift
Curette per sinus lift

Knocheninstrumente

Bone instruments
Instrumentos para hueso
Instruments à l'os
Strumenti per osso

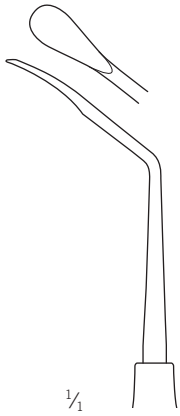
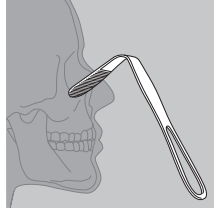

$\frac{1}{1}$

Fig. 3
38-017-03
19 cm / 7 $\frac{4}{8}$ "

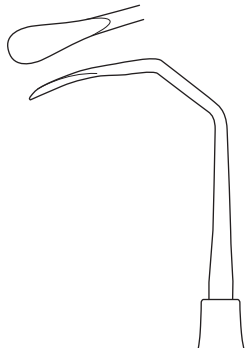
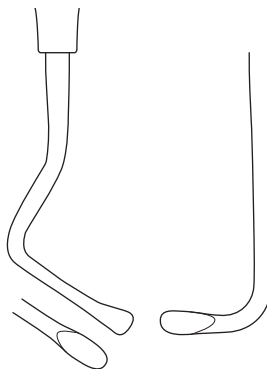
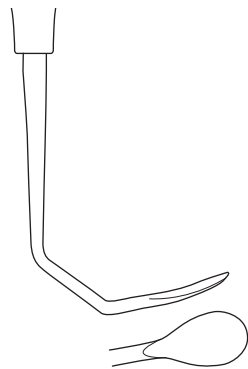
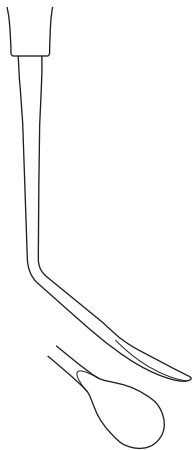
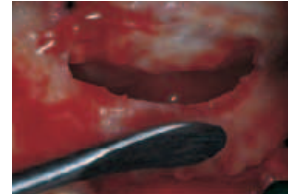
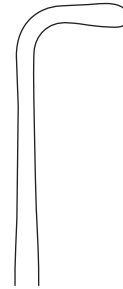

Fig. 4
38-017-04
17 cm / 6 $\frac{6}{8}$ "



Fig. 5
38-017-05
18 cm / 7 $\frac{1}{8}$ "



Sinus-Krallenhaken nach Lindorf

Sinus-Krallenhaken acc. to Lindorf

Separador-garra sinus según Lindorf

Retracteur sinus griffe selon Lindorf

Divaricatore-artiglio sinus secondo Lindorf



Lindorf
38-527-01

19,5 cm / 7 5/8"

Sinus-Krallenhaken, links
Sinus claw retractor, left
Separador-garra sinus, izquierda
Retracteur sinus griffe, gauche
Divaricatore-artiglio sinus, sinistra



Lindorf
38-527-02

19,5 cm / 7 5/8"

Sinus-Krallenhaken, rechts
Sinus claw retractor, right
Separador-garra sinus, derecha
Retracteur sinus griffe, droite
Divaricatore-artiglio sinus, destra

Sagittale Ramusosteotomie nach Lindorf

Sagittal ramus osteotomies acc. to Lindorf
 Osteotomía sagital de rama mandibular según Lindorf
 Ostéotomie sagittale du ramus selon Lindorf
 Osteotomia sagittale del ramo secondo Lindorf

Knocheninstrumente

Bone instruments
 Instrumentos para hueso
 Instruments à l'os
 Strumenti per osso

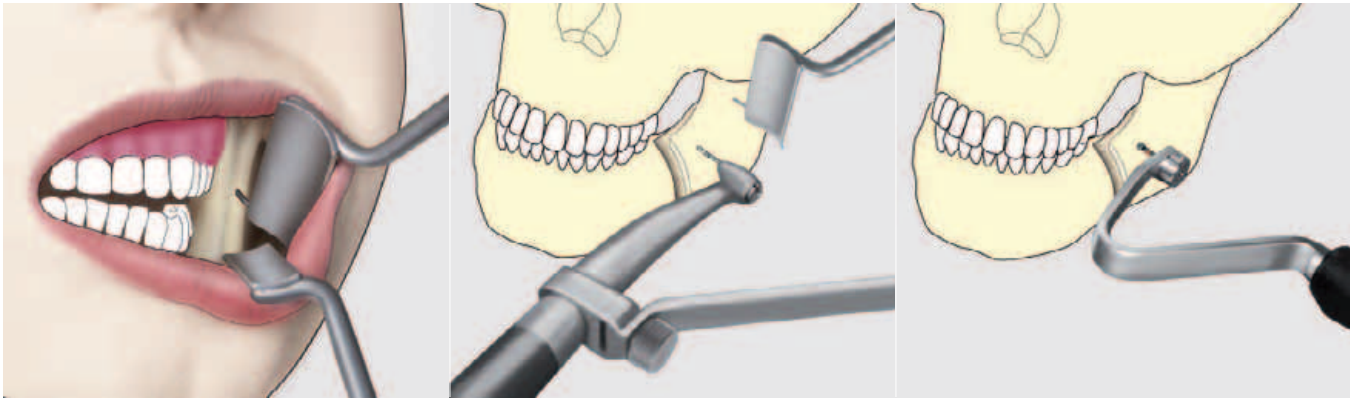
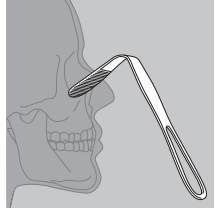

1/2

Lindorf
 50-580-00

18 cm / 7 1/8"

Enorale Bohr- und Schraubhilfe
 Enoral drilling and screwing aid
 Ayuda per perforar y atornillar
 Aide de forage et vissage
 Aiuto per perforare e avviate



1/2

Lindorf
 50-541-00

18 cm / 7 1/8"

Explantationsinstrument
 Explantation instrument
 Instrument para explantacion
 Instrument d'explantaton
 Strumento per explantazione

Einsätze für Schrauben
 Blades for screws
 Terminales para tornillos
 Lames pour vis
 Lame per viti

Centre Drive®

- 1,5 mm ● ⊕ 50-910-15
- 2,0/2,3 mm ● ⊕ 50-910-20
- 2,7 mm ○ ⊕ 50-910-27

Cross Drive

- 1,5 mm ● ⊕ 50-915-15
- 2,0/2,3 mm ● ⊕ 50-915-20
- 2,7 mm ○ ⊕ 50-915-27

Sagittale Ramusosteotomie nach Lindorf

Sagittal ramus osteotomies acc. to Lindorf

Osteotomía sagital de rama mandibular según Lindorf

Ostéotomie sagittale du ramus selon Lindorf

Osteotomia sagittale del ramo secondo Lindorf

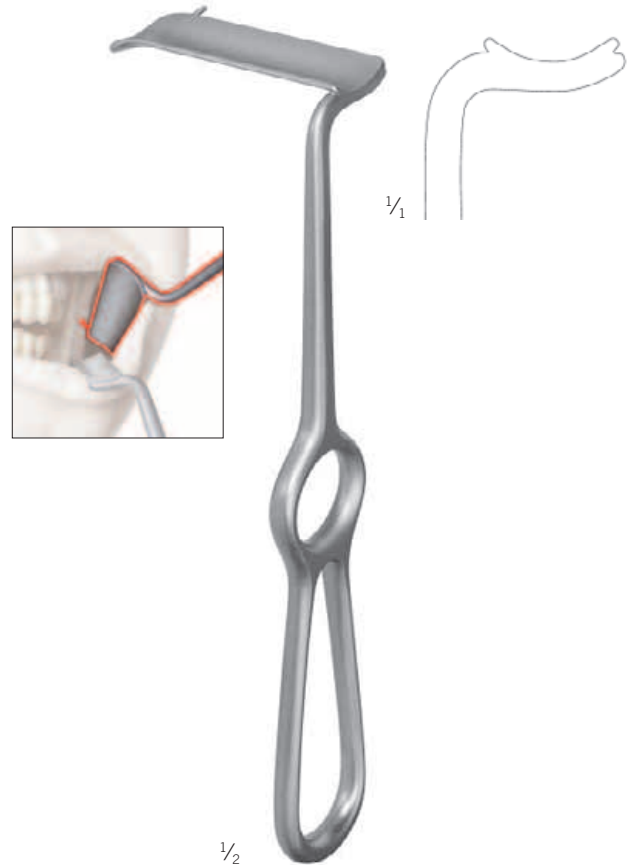
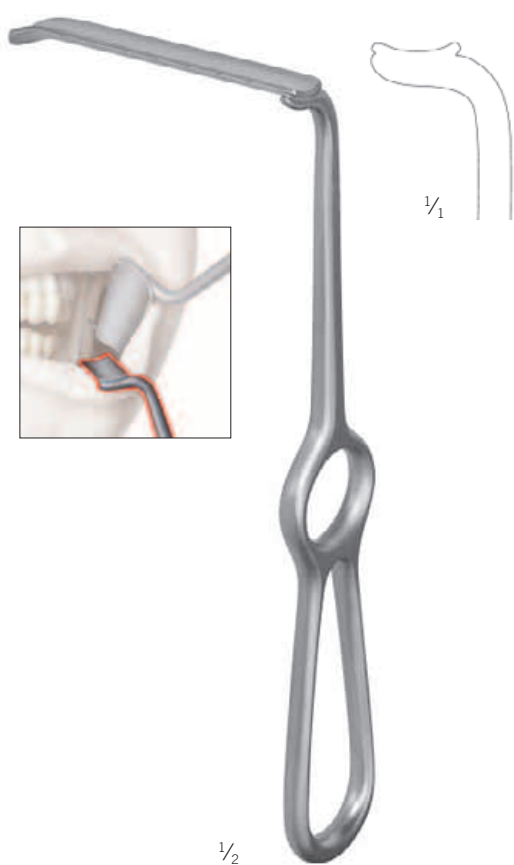
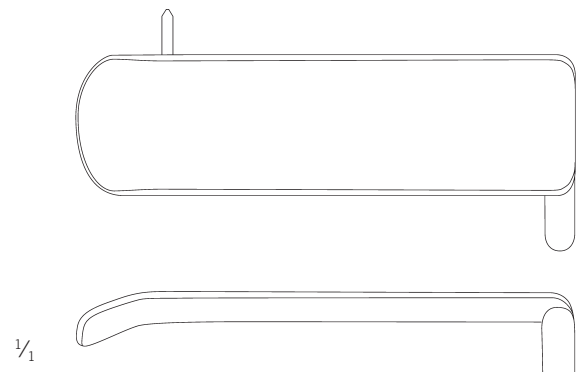
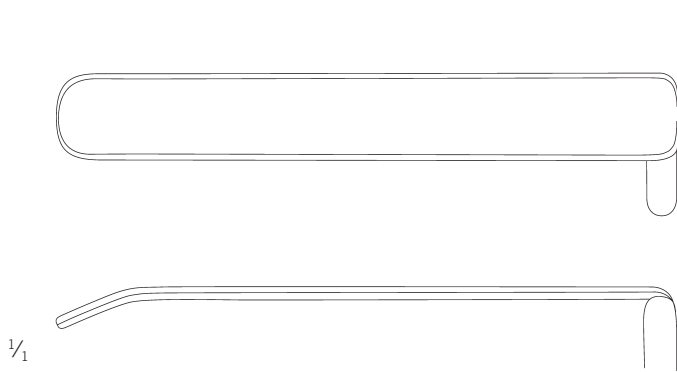

Lindorf
38-525-01

19,5 cm / 7 5/8"

Side-Step-Haken, links unten

Side-step retractor, left-side, lower region

Side-step retractor, left-side, lower region

Separador tipo "side-step", lado izquierdo, región inferior

Rétracteur «side-step», côté gauche, région inférieure

Retrattore "side-step", lato sinistro, regione inferiore

Lindorf
38-526-01

19,5 cm / 7 5/8"

Ramus-Krallenhaken, links oben

Hook-type ramus retractor, left-side, upper region

Separador de rama mandibular tipo garra,

lado izquierdo, región superior

Rétracteur à crochet pour ramus, côté gauche,

région supérieure

Retrattore ad uncino per ramo, lato sinistro,

regione superiore

Sagittale Ramusosteotomie nach Lindorf

Sagittal ramus osteotomies acc. to Lindorf
 Osteotomía sagital de rama mandibular según Lindorf
 Ostéotomie sagittale du ramus selon Lindorf
 Osteotomia sagittale del ramo secondo Lindorf

Knocheninstrumente

Bone instruments
 Instrumentos para hueso
 Instruments à l'os
 Strumenti per osso

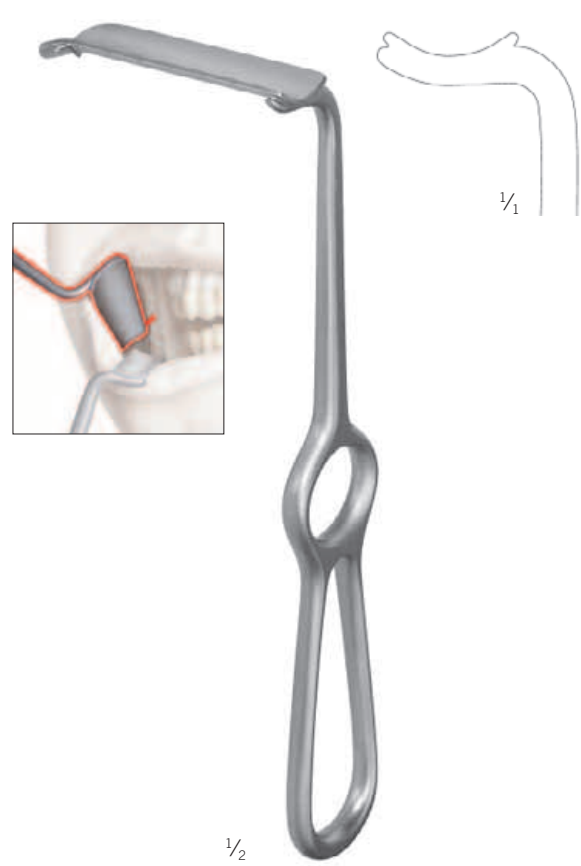
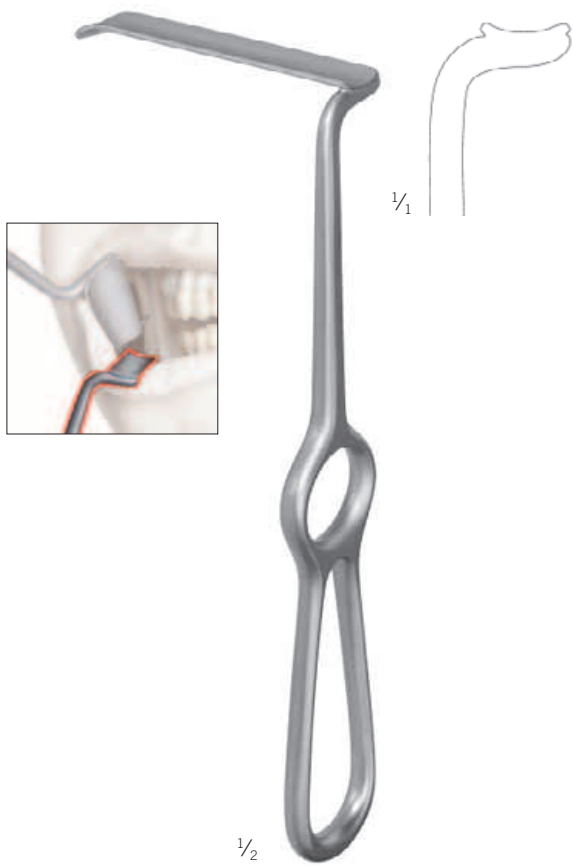
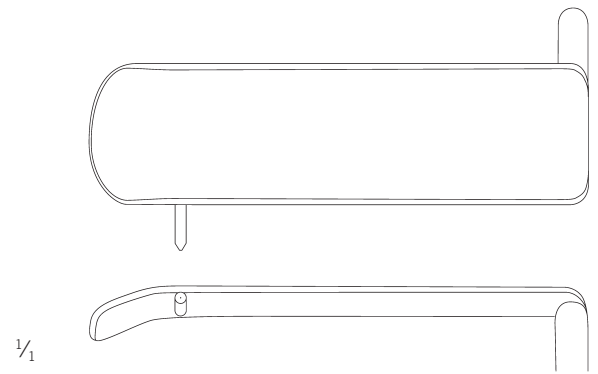
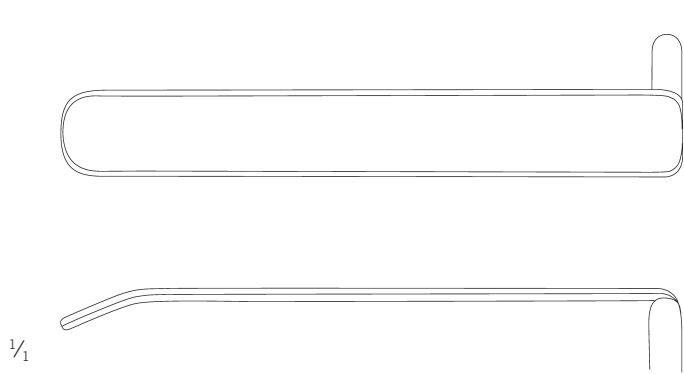
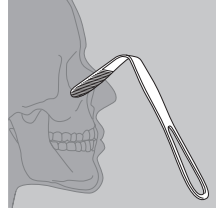

Lindorf
38-525-02
 19,5 cm / 7 5/8"
 Side-Step-Haken, rechts unten
 Side-step retractor, right-side, lower region
 Separador tipo "side-step", lado derecho, región inferior
 Rétracteur «side-step», côté droit, région inférieure
 Retratore "side-step", lato destro, regione inferiore

Lindorf
38-526-02
 19,5 cm / 7 5/8"
 Ramus-Krallenhaken, rechts oben
 Hook-type ramus retractor, right-side, upper region
 Separador de rama mandibular tipo garra, lado derecho, región superior
 Rétracteur à crochet pour ramus, côté droit, région supérieure
 Retratore ad uncino per ramo, lato destro, regione superiore

Minimal invasive Sinus-Lift-Küretten

Elevators, Graft Packers, Burrs

Elevadores, Atacadores de trasplantes, Fresas

Elévateurs, Poussoirs pour transplantation, Mèches

Elevatori, Turatori per innesti, Alesatori

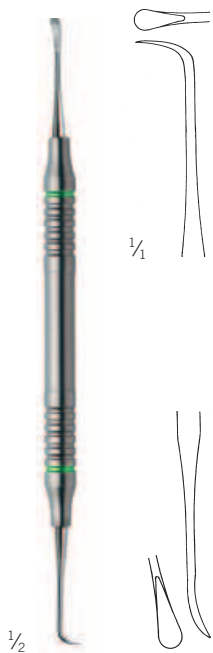

Meiß
38-020-01
16,5 cm / 6 4/8"

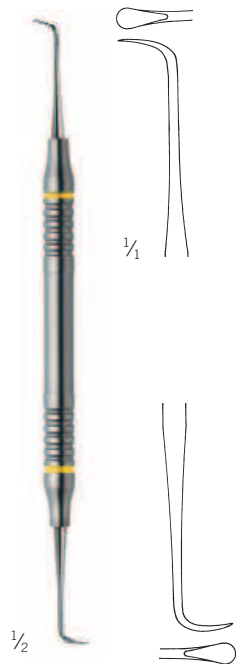

Meiß
38-020-02
16,5 cm / 6 4/8"

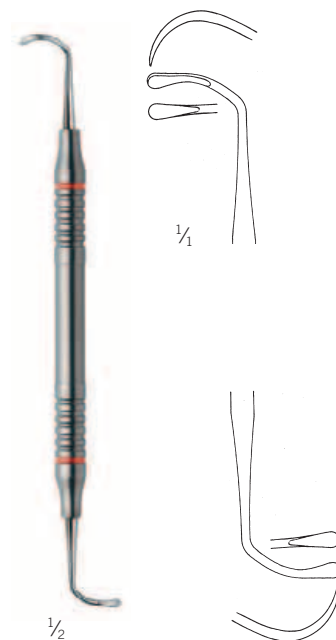

Meiß
38-020-03
16,5 cm / 6 1/8"

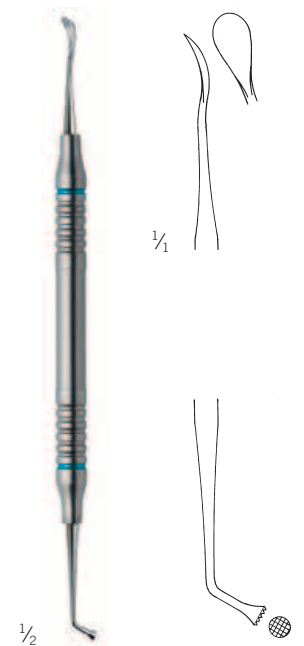

Meiß
38-020-04
16,5 cm / 6 4/8"

Knochenfalle

Bonetrap
 Colector óseo
 Collecteur d'os
 Raccoglio osso

Knocheninstrumente

Bone instruments
 Instrumentos para hueso
 Instruments à l'os
 Strumenti per osso

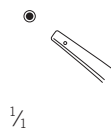
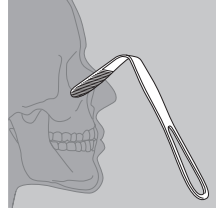

18-501-14
 14,5 cm / 5 6/8"
 1,5 mm Ø

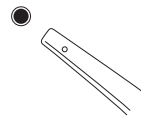

18-502-14
 14,5 cm / 5 6/8"
 2,5 mm Ø

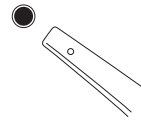

18-503-14
 14,5 cm / 5 6/8"
 3 mm Ø

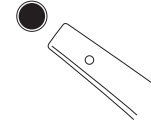

18-504-14
 14,5 cm / 5 6/8"
 4 mm Ø

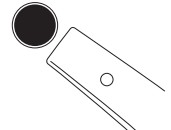

18-506-14
 14,5 cm / 5 6/8"
 6 mm Ø

18-501-18
 18 cm / 7 1/8"
 1,5 mm Ø

18-502-18
 18 cm / 7 1/8"
 2,5 mm Ø

18-503-18
 18 cm / 7 1/8"
 3 mm Ø

18-504-18
 18 cm / 7 1/8"
 4 mm Ø

18-506-18
 18 cm / 7 1/8"
 6 mm Ø

1/2



1/2

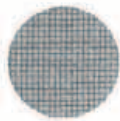

1/1

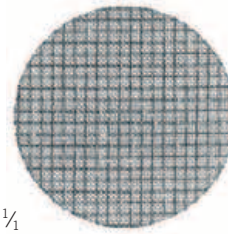

38-025-00

Knochenfalle, bestehend aus Becher, Deckel, Auswurfstößel, 1x Filtereinlage
 Bonetrap, consisting of cup, lid, lifter, 1 x filter
 Colector óseo cont. vaso, tapa, empujador, 1 x filtro
 Collecteur d'os, avec gabelet, couvercle, pousoir, 1 x filtre
 Raccoglio osso consistente in contenitore base, coperchio, beccuccio, 1 x griglia

38-025-01

Knochenfilter zum einmaligen Gebrauch
 Bonefilter for single use only
 Filtro de hueso para uso solo
 Filtre d'os, usage unique
 Filtro osso per applicazione singola

Knochenquetsche, Knochenmühle

Bone crusher, bone mill

Aplastador óseo, molino de huesos

Presse d'os, broyeur d'os

Strumento per schiacciamento ossa

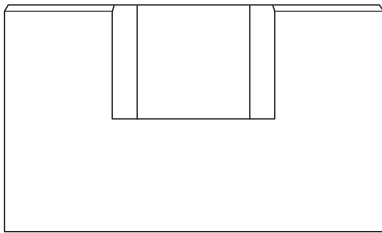
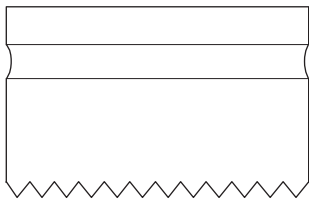
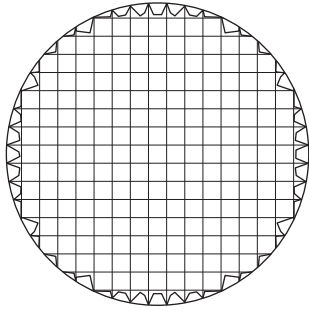

1/4



1/2

38-018-01



1/2

38-019-01

16,5 cm / 6 4/8"

Knochenmühle für kleine bis mittlere Knochenmenge

Bone mill for small and medium quantities

Molino de huesos para cantidades pequeñas y medias

Broyeur d'os pour des quantités petites et moyennes

Mollino d'osso per quantità piccola e mediale



Trepanbohrer

Trephine burs

Trephine

Fraises à carotter tréphine

Fresa carotatrici trephine

Knocheninstrumente

Bone instruments

Instrumentos para hueso

Instrumenti à l'os

Strumenti per osso

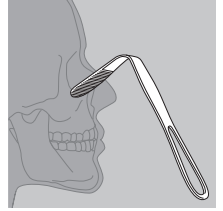

	38-030-03	38-030-05	38-030-08	38-030-10
Ø a	3,0 mm	5,0 mm	7,5 mm	10,0 mm
Ø b	3,5 mm	6,0 mm	8,5 mm	11,0 mm

	38-032-03	38-032-05	38-032-08	38-032-10
Ø a	3,0 mm	5,0 mm	7,5 mm	10,0 mm
Ø b	3,5 mm	6,0 mm	8,5 mm	11,0 mm

38

Trepanbohrer

Trephine burs

Trephine

Fraises à carotter tréphine

Frese carotatrici trephine

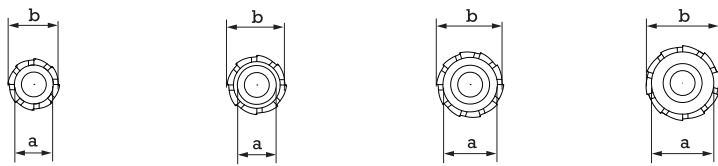
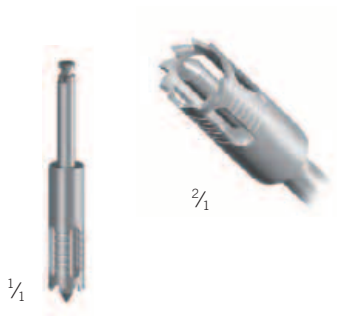

Trepanbohrer mit Führungstift
Trephinebur guided
Trephine guiado
Trephine avec guidage
Trapano c. candela

	38-033-01	38-033-02	38-033-03	38-033-04
Ø a	2,5 mm	3,0 mm	3,5 mm	4,0 mm
Ø b	3,3 mm	3,8 mm	4,3 mm	4,8 mm

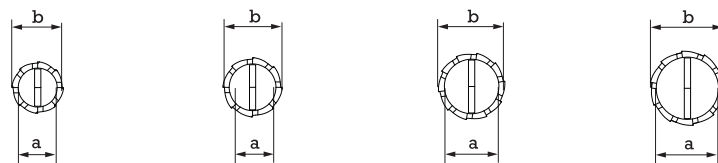

Trepanbohrer mit Schwert
Trephinebur w. sword
Trephine c. espada
Trephine avec dérive
Trapano c. spada

	38-034-01	38-034-02	38-034-03	38-034-04
Ø a	2,5 mm	3,0 mm	3,5 mm	4,0 mm
Ø b	3,3 mm	3,8 mm	4,3 mm	4,8 mm

Zur Entnahme von autologem Knochen. Das gewonnene Knochenmaterial wird beim Trepanieren selbstständig partikuliert.

For autogenous bone harvesting. The harvested material is automatically particulated during trepanation.

Para la extracción de hueso autólogo. El material así obtenido automáticamente es particulado durante la trepanación.

Pour le prélèvement d'os autologe. Le matériel osseux obtenu est particulé automatiquement pendant la trépanation.

Per la raccolta di osso autogeno. Il materiale raccolto viene automaticamente particolato durante la trapanatura.

Knochenspritzen

Bone carriers
Jeringas de hueso
Seringues à os
Siringhe per osso

Knocheninstrumente

Bone instruments
Instrumentos para hueso
Instruments à l'os
Strumenti per osso

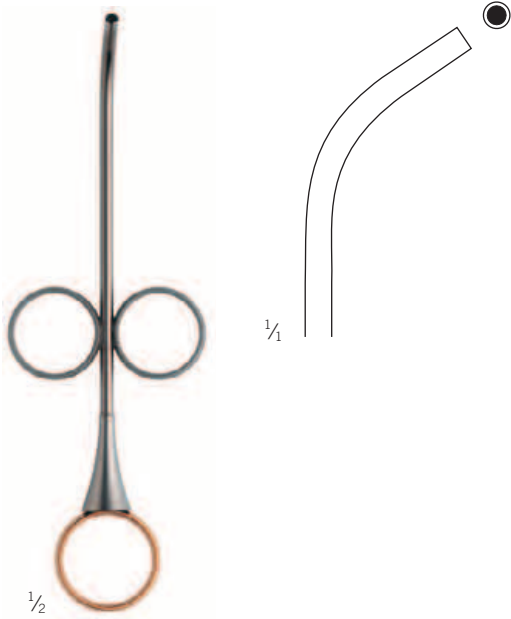
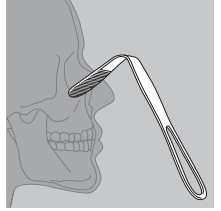

Fig. 01
38-040-02
2,5/3,5 mm

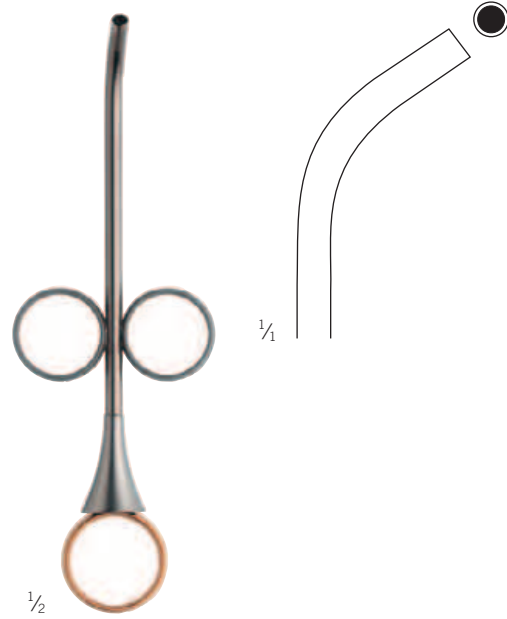

Fig. 02
38-040-04
3,5/4,5 mm

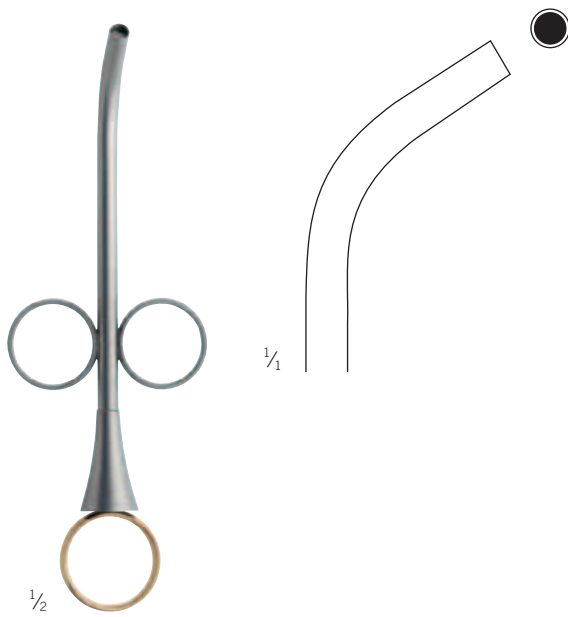

Fig. 03
38-040-06
4,5/5,5 mm



Fig. 04
38-040-08
6/7 mm

Fräser, Fingerschutz, Mundkeile

Burrs, Finger Protector, Mouth Gags

Fresas, Dedal, Abre bocas

Mèches, Doigtiers, Baïllons

Alesatori, Protettore per dita, Apribocca



1/1



1/1

38-050-45
4,5 cm / 1 6/8"



Arbeitslänge
working length
largo útil
longueur utile
lunghezza utile
10 mm



1/1

38-050-65
6,5 cm / 2 1/8"



Arbeitslänge
working length
largo útil
longueur utile
lunghezza utile
22 mm



1/1

38-050-80
8 cm / 3 1/8"



Arbeitslänge
working length
largo útil
longueur utile
lunghezza utile
35 mm



1/1

38-051-45
4,5 cm / 1 6/8"



Arbeitslänge
working length
largo útil
longueur utile
lunghezza utile
10 mm

Lindemann

38-050-45 - 38-051-45

zur vertikalen Spaltung im bukkalen Bereich des Unterkiefers

for vertical cuts in the buccal aspect of the mandible

para cortes verticales en el aspecto bucal de la mandíbula

pour séparation verticale dans la zone buccale mandibulaire dans la mâchoire inférieure

per osteotomie verticali nella zona buccale della mandibula



1/2

Adams
38-103-01

Serviettenhalter
Napkin Holder
Porta-servilleta
Porte-serviettes
Porta-salvietta



1/2

Langenbeck
38-111-02

Ø 26 / 20 mm



1/2

Maunder
38-120-10

9,5 cm / 3 6/8"
Holz
wood
madera
bois
legno



1/2

Pitha
38-127-02

Silikon
silicone
silicona
silicone
silicona
28 x 30 mm

Mundkeile, Mundsperrer

Mouth Gags, Mouth Gags
 Abrebocas, Abrebocas
 Baïllons, Ouvre-bouche
 Apribocca, Apribocca

Knocheninstrumente

Bone instruments
 Instrumentos para hueso
 Instruments à l'os
 Strumenti per osso

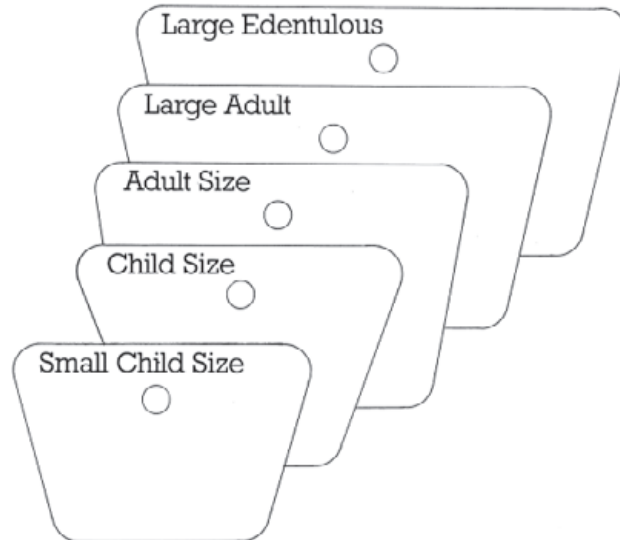
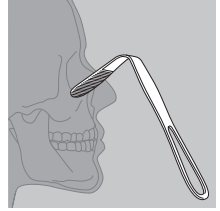

38-130-50

extra groß, für Zahnlose
 extra large, for edentulous
 muy grande, para desdentados
 très grand, pour édentés
 molto grande, per sdentati

38-130-54

normal, für Erwachsene
 regular, for adults
 regular, para adultos
 regulier, pour adultes
 regolare, per adulti

38-130-52

groß, für Erwachsene
 large, for adults
 grande, para adultos
 grand, pour adultes
 grande, per adulti

38-130-58

klein, für Kleinkinder
 small, for babies
 pequeño, para bebés
 petit, pour bébés
 piccolo, per neonati

38-130-56

klein, für Kinder
 small, for children
 pequeño, para niños
 petit, pour enfants
 piccolo, per bambini

38-130-90

Kette, allein
 Chain, only
 Cadena, suelto
 Chaîne, seul
 Catena, solo



1/1

McKesson

kunststoffbeschichteter Metallrahmen
 ohne Kette
 plastic coated metal frame
 without chain
 cuadro metálico, cubierto de plástico
 sin cadena
 cadre métal avec revêtement synthétique
 sans chaîne
 telaio metallico, ricoperto in plastica
 senza catena



1/2

Heister
 38-140-13
 13 cm / 5 1/8"



1/2

Obwegeser
 38-150-11
 11 cm / 4 3/8"

Spreizweite
 spreading
 extensión
 écartement
 apertura
 47 mm

Mundsperrer

Mouth Gags
Abrebocas
Ouvre-bouche
Apribocca

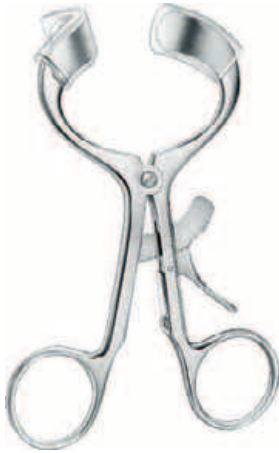

1/2

Molt
38-161-11
11 cm / 4 3/8"

38-161-92
Ersatzgummi
Spare Rubber
Goma de repuesto
Caoutchouc de remplacement
Gomma di ricambio



38-161-11



1/2

Molt
38-161-14
13 cm / 5 1/8"

38-161-93
Ersatzgummi
Spare Rubber
Goma de repuesto
Caoutchouc de remplacement
Gomma di ricambio



38-161-14



1/2

Denhart
38-171-12
13 cm / 5 1/8"

Backen
jaws
bocas
mors
branche
16 mm



1/2

Roser-König
38-179-16 - 38-179-20

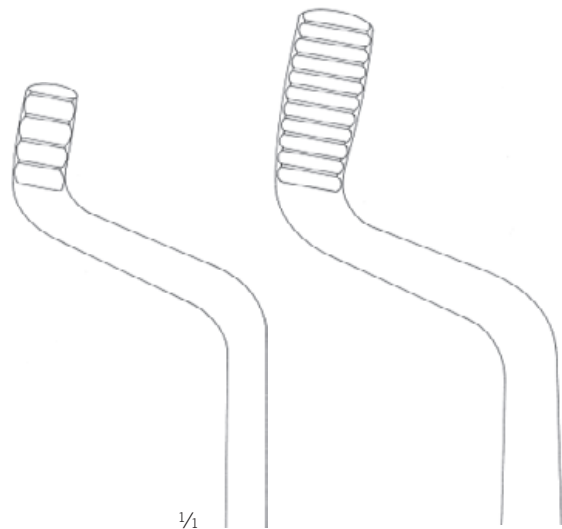

1/1

38-179-16
16 cm / 6 2/8"

38-179-20
19 cm / 7 4/8"

Lippen- und Wangenhalter

Lip and Cheek Retractors
 Separadores para labios y mejillas
 Ecarteurs des lèvres et joues
 Separatori per labbra e guancia

Knocheninstrumente

Bone instruments
 Instrumentos para hueso
 Instruments à l'os
 Strumenti per osso

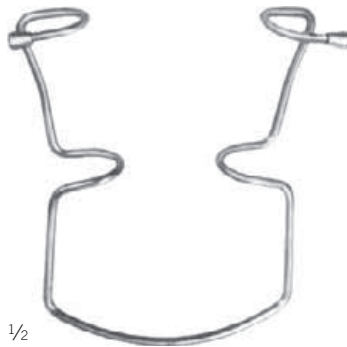
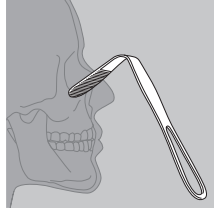

1/2

Oringer 38-240-00

9,5 cm / 3 6/8"

selbsthaltend, für Kinder
 self retaining, for children
 autoestático, para niños
 autostatique, pour enfants
 autostatico, per bambini

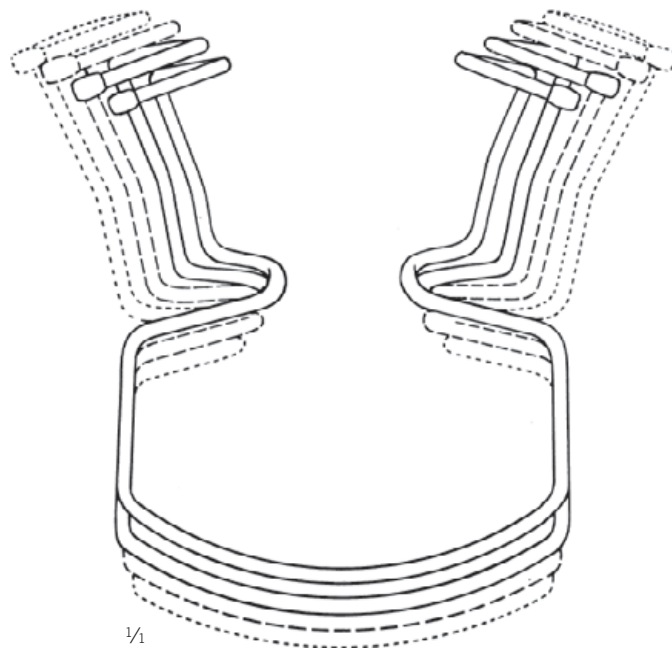

1/1

Fig. 1 38-240-01 10 cm / 3 7/8"

Fig. 2 38-240-02 10,5 cm / 4 1/8"

Fig. 3 38-240-03 11 cm / 4 3/8"

38-240-13

selbsthaltend
 self retaining
 autoestático
 autostatique
 autostatico

Satz mit Fig. 1-3
 set with no. 1-3
 juego de no. 1-3
 jeu de no. 1-3
 set con no. 1-3

Lippen- und Wangenhalter

Lip and Cheek Retractors

Separadores para labios y mejillas

Ecarteurs des lèvres et joues

Separatori per labbra e guancia



1/2

Martin-Simplex
38-243-11
10,5 cm / 4 1/8"



1/2

38-246-14
14 cm / 5 4/8"
Vestibulumhaken
Vestibulum Retractor
Separador para vestibulo
Ecarteur pour vestibulum
Separatore per vestibulo



1/2

Sternberg
38-249-14
14 cm / 5 4/8"

26 mm

37 mm

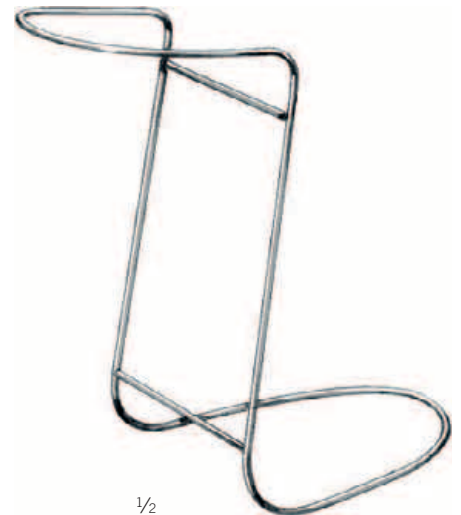

1/2

Obwegeser
38-251-12
12 cm / 4 6/8"



1/2

Bishop
38-261-13
13,5 cm / 5 3/8"



1/2

Cawood-Minnesota
38-263-15
15,5 cm / 6 1/8"



1/2

Cawood-Minnesota
38-265-00
14,5 cm / 5 6/8"



1/2

Zungendrucker

Tongue Depressors
Abajalenguas
Abaisse-langue
Abassalingua

Knocheninstrumente

Bone instruments
Instrumentos para hueso
Instruments à l'os
Strumenti per osso

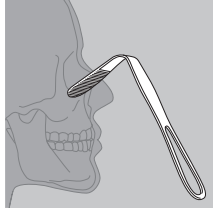

1/2

Hartmann
38-271-15
15 cm / 5 7/8"



1/1

72 x 24 mm



1/2

Tobold
38-277-14
15 cm / 5 7/8"



1/1

83 x 25 mm



Tobold
38-281-14
16 cm / 6 3/8"



1/1

80 x 25 mm



1/2

Wieder
38-297-01 - 38-297-02

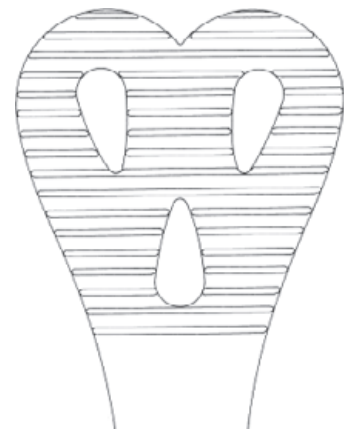

38-297-02
15 cm / 5 7/8"
43 mm

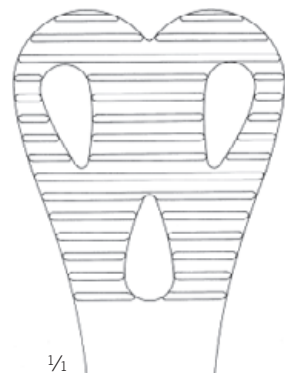

1/1

38-297-01
14 cm / 5 4/8"
36 mm

38

Zungenspatel

Tongue Spatulas
Espátulas linguales
Abaisse-langue
Spatole per lingua



1/2

38-350-16

15 cm / 5 7/8"

Holz
wood
madera
bois
legno

19 mm

Packung mit 100 Stück
package of 100 pieces
paquete con 100 piezas
paquet avec 100 pièces
confezione di 100 pezzi



1/2

38-352-15

15 cm / 5 7/8"

Kunststoff
plastic
plástico
matière plastique
plastica

Packung mit 100 Stück
package of 100 pieces
paquete con 100 piezas
paquet avec 100 pièces
confezione di 100 pezzi



1/2

Ny

Martin

38-363-18

18,5 cm / 7 2/8"



1/2

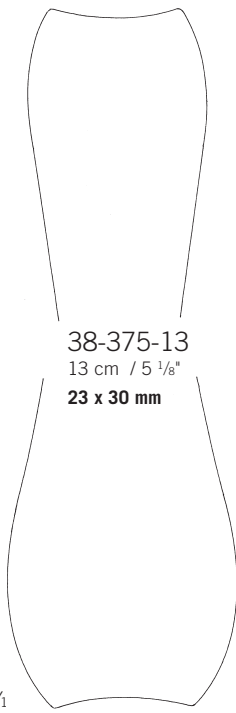

1/1

38-375-13

13 cm / 5 1/8"

23 x 30 mm

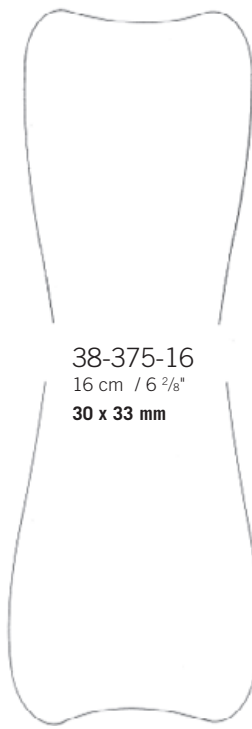

38-375-16

16 cm / 6 2/8"

30 x 33 mm



1/2

15 mm

19 mm

Doyen
38-375-13 - 38-375-16

Brünings
38-385-19
19 cm / 7 4/8"

Weisheitszahnhaken

Third molar hook

Ganchito retractor de la muela del juicio

Crochet à dent de sagesse

Uncino per dente del giudizio

Knocheninstrumente

Bone instruments

Instrumentos para hueso

Strumenti à l'os

Strumenti per osso

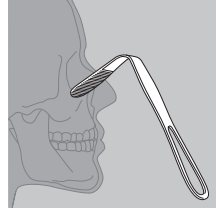

Henahan
38-403-01 - 38-403-03



Fig. 1
38-403-01
18 cm / 7 1/8"



Fig. 2
38-403-02
18 cm / 7 1/8"



Fig. 3
38-403-03
18 cm / 7 1/8"

Weisheitszahnhook

Third molar hook

Ganchito retractor de la muela del juicio

Crochet à dent de sagesse

Uncino per dente del giudizio



1/4

Henahan
38-403-11 - 38-403-13



1/4

Fig. 1-1
38-403-11
20 cm / 7 7/8"



Fig. 1-2
38-403-12
20 cm / 7 7/8"



Fig. 1-3
38-403-13
20 cm / 7 7/8"



Zungenzangen, Ramushaken

Tongue Holding Forceps, Ramus Retractors
 Pinzas tira-lengua, Separadores para el ramo
 Pincas tire-langue, Ecarteurs pour ramus
 Pinze per lingua, Separatore per ramo

Knocheninstrumente

Bone instruments
 Instrumentos para hueso
 Instruments à l'os
 Strumenti per osso

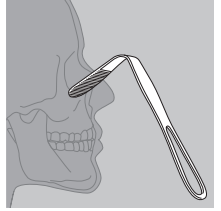

1/2

Collin
 38-452-17
 17 cm / 6 5/8"



1/2

Young
 38-467-17
 15 cm / 5 7/8"



1/1

Young
 38-468-02
 Gummipolster
 Rubber Inserts
 Bocas de goma
 Mors en caoutchouc
 Cuscino di gomma

Paar
 pair
 par
 paire
 paio



38-467-17



1/2

Obwegeser
 38-607-22
 22 cm / 8 5/8"

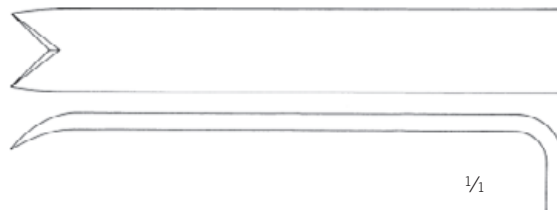

1/1

72 x 10 mm

Osteotome, Ramusosteotome

Osteotomes, Ramus Osteotomes
 Osteótomos, Osteótomos de rama
 Ostéotomes, Ostéotome pour ramus
 Osteotomi, Osteotomi per ramo

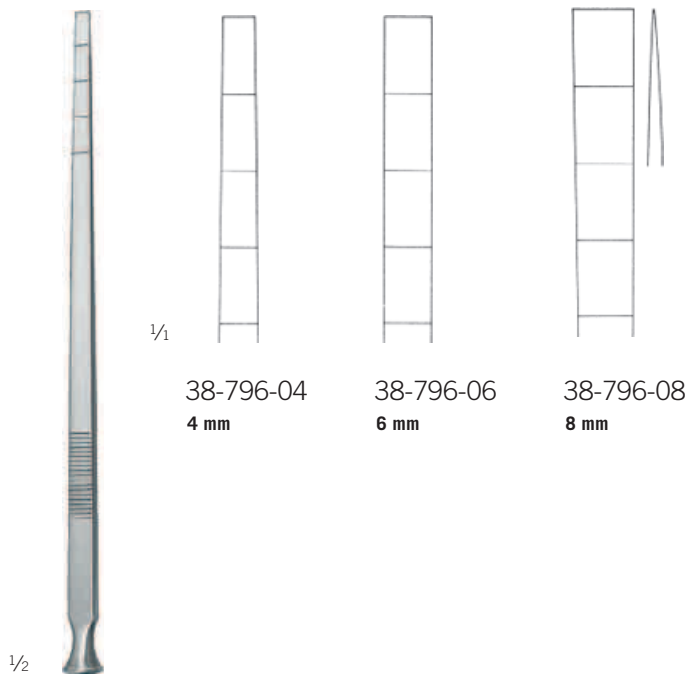

Epker
 38-796-04 - 38-796-08
 18 cm / 7 1/8"

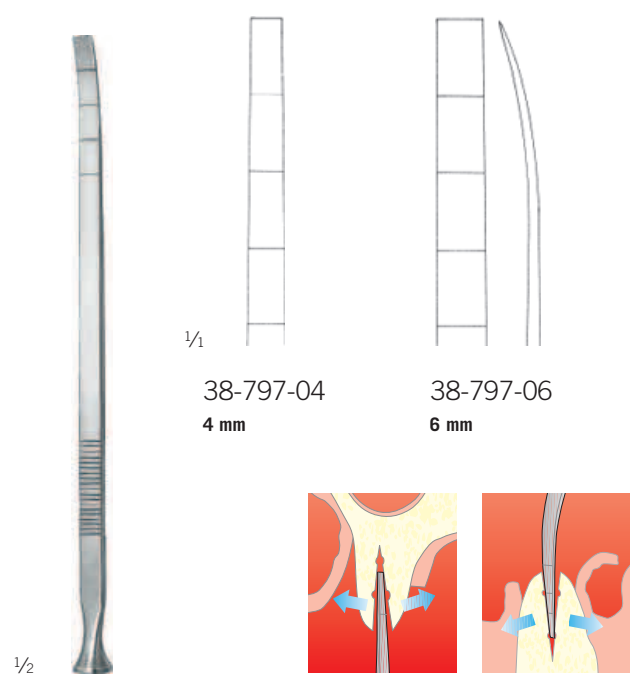

Epker
 38-797-04 - 38-797-06
 18 cm / 7 1/8"

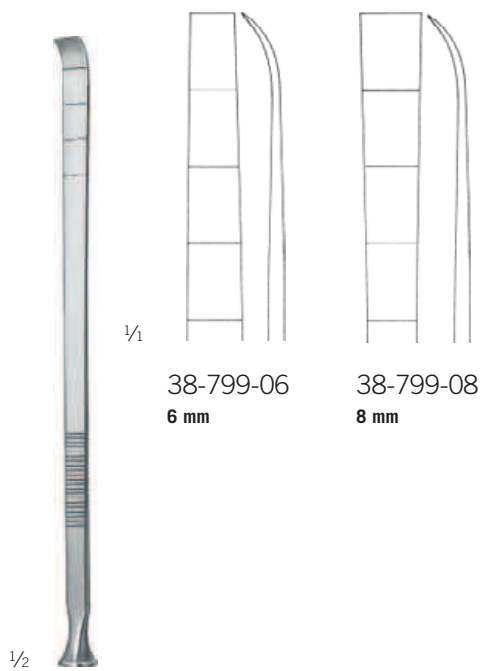

Epker
 38-799-06 - 38-799-08
 18 cm / 7 1/8"

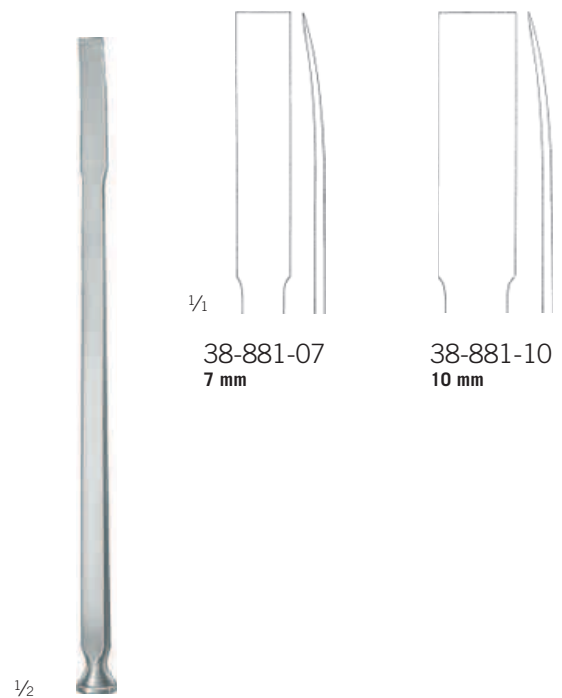

Steinhäuser
 38-881-07 - 38-881-10
 17 cm / 6 6/8"
 flexibel
 flexible
 flexible
 flexible
 flessibile

Meißel, Parodontalmeißel

Chisels, Periodontal chisels
 Cinceles, Cinceles de periodoncia
 Ciseaux-burins, Burins de parodontie
 Scalpelli, Sgorbie per parodontologia

Knocheninstrumente

Bone instruments
 Instrumentos para hueso
 Instruments à l'os
 Strumenti per osso

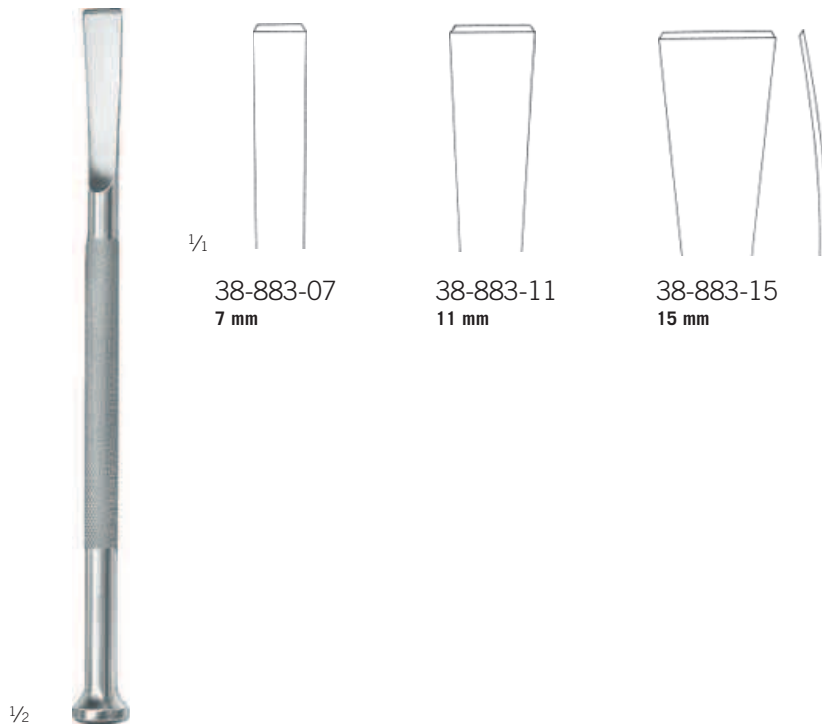
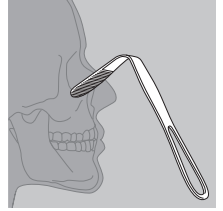

1/1
 38-883-07
 7 mm

38-883-11
 11 mm

38-883-15
 15 mm

Steinhäuser

38-883-07 - 38-883-15

19 cm / 7 5/8"

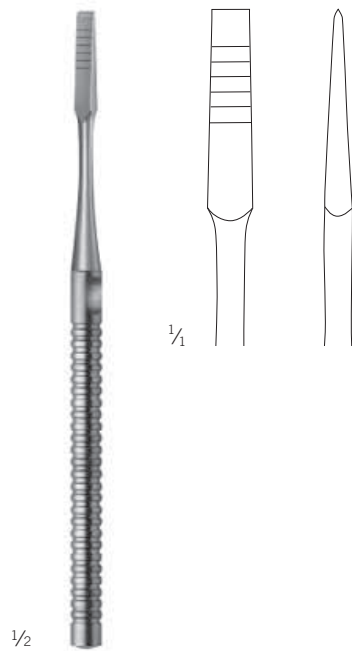

Iglhaut
 38-800-04
 17 cm / 6 5/8"

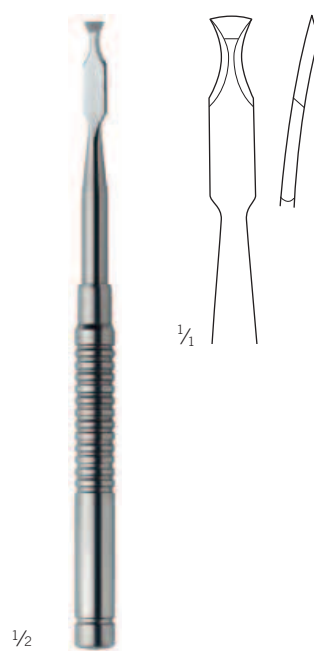

Ochsenbein
 43-365-01
 17 cm / 6 5/8"

Fig. 1
 aufwärts gebogen
 curved upwards
 curvos hacia arriba
 courbé vers le haut
 curvo verso l'alto

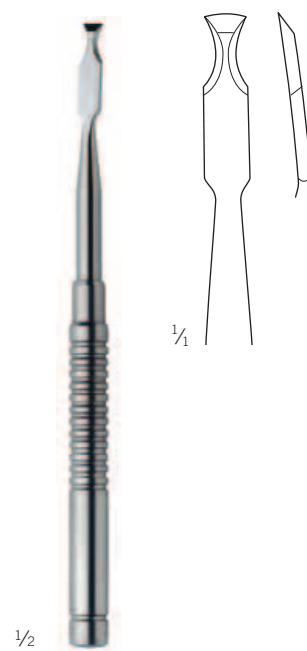

Ochsenbein
 43-365-02
 17 cm / 6 5/8"

Fig. 2
 abwärts gebogen
 curved downwards
 curvos hacia abajo
 courbé vers le bas
 curvo verso il basso

Osteotome

Osteotomes
 Osteótomos
 Ostéotomes
 Osteotomi

3 mm-Längen-Graduierung
 3 mm length graduation
 graduación longitudinal de 3 mm
 graduation en longueur de 3 mm
 graduazione longitudinale da 3 mm

Schlagen von Pin-Bohrungen durch resorbierbare Membranen hindurch. Vorbohrung in der Maxilla nicht notwendig. Auch geeignet für den ersten Schritt bei der Summers-Technik.

Make pin holes through resorbable membranes.
 No predrilling required in maxilla. Also suitable for first step in Summers technique.

Para hacer agujeros muy pequeños a través de membranas resorbibles. El pretaladrado maxilar no es necesario. También apropiado para el primer paso en la técnica Summers.

Création de trous par enfoncement au travers des membranes résorbables. Préforage dans le maxillaire n'est pas nécessaire. Aussi approprié à la première phase de la technique selon Summers.

Realizzazione di fori attraverso membrane riassorbibili. Non è richiesta alcuna foratura preliminare nella regione mascellare. Appropriato anche per i primi passi nella tecnica di Summers.



Körner-Westermann
 43-894-01

17,5 cm / 6 7/8"

1 mm Ø

Pin-Osteotom
 Pin osteotome

Osteótomo para agujeros muy pequeños
 Ostéotome pour trous à broche par enfoncement
 Osteotomo per barra di ritenzione dentaria

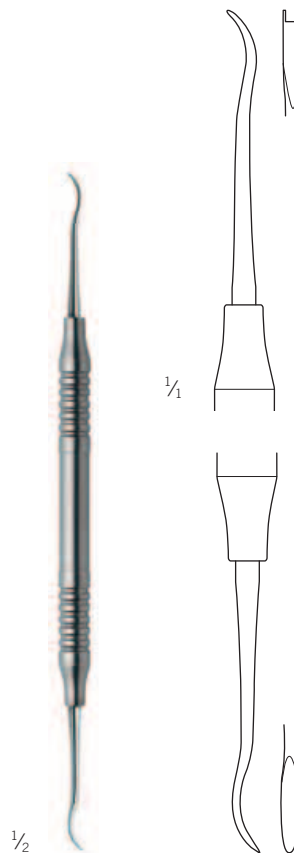

Körner-Westermann
 23-500-02

18 cm / 7 1/8"

Membran-Platzierinstrument, zum Platzieren und Fixieren von Membranen
 Membrane placing instrument, for placing and fixing membranes
 Instrumento para colocar membranas, para colocar y fijar membranas
 Instrument d'application de membrane, pour placer et fixer des membranes
 Strumento per l'applicazione della membrana, per il posizionamento e il fissaggio delle membrane



Osteotome

Osteotomes
Osteótomos
Ostéotomes
Osteotomi

Knocheninstrumente

Bone instruments
Instrumentos para hueso
Instruments à l'os
Strumenti per osso

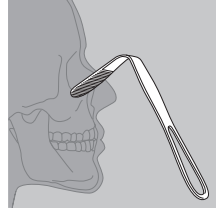

1/2

Iglhaut
43-600-00 - 43-600-05
17,5 cm / 6 7/8"



1/4

43-600-00

Fig. 0

Ø 2,2 mm < Ø 2,7 mm



43-600-01

Fig. 1

Ø 2,7 mm < Ø 3,2 mm



43-600-02

Fig. 2

Ø 3,2 mm < Ø 3,7 mm



1/4

43-600-03

Fig. 3

Ø 3,7 mm < Ø 4,2 mm



43-600-04

Fig. 4

Ø 4,2 mm < Ø 4,7 mm



43-600-05

Fig. 5

Ø 4,7 mm < Ø 5,4 mm

Osteotome

Osteotomes
Osteótomos
Ostéotomes
Osteotomi



Iglhaut
43-601-00 - 43-601-05
17,5 cm / 6 7/8"



43-601-00

Fig. 0
Ø 2,2 mm < Ø 2,7 mm



43-601-01

Fig. 1
Ø 2,7 mm < Ø 3,2 mm



43-601-02

Fig. 2
Ø 3,2 mm < Ø 3,7 mm



43-601-03

Fig. 3
Ø 3,7 mm < Ø 4,2 mm



43-601-04

Fig. 4
Ø 4,2 mm < Ø 4,7 mm



43-601-05

Fig. 5
Ø 4,7 mm < Ø 5,4 mm

Osteotome

Osteotomes
Osteótomos
Ostéotomes
Osteotomi

Knocheninstrumente

Bone instruments
Instrumentos para hueso
Instruments à l'os
Strumenti per osso

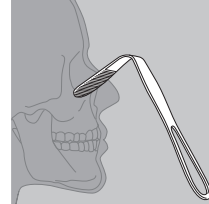

1/2

Iglhaut
43-805-01 - 43-805-03
17,5 cm / 6 7/8"



1/4

43-805-01
Fig. 1
1,6 mm
gerade
straight
recto
droit
diritto



43-809-02
Fig. 2
1,6 mm < 2,2 mm
gerade
straight
recto
droit
diritto



43-809-03
Fig. 3
2,2 mm
gerade
straight
recto
droit
diritto



1/2

Iglhaut
43-806-01 - 43-806-03
17,5 cm / 6 7/8"



1/4

43-806-01
Fig. 1
1,6 mm
bajonett
bayonet
bayoneta
baïonnette
bajonetta



43-896-02
Fig. 2
1,6 mm < 2,2 mm
bajonett
bayonet
bayoneta
baïonnette
bajonetta



43-896-03
Fig. 3
2,2 mm
bajonett
bayonet
bayoneta
baïonnette
bajonetta

Halbstanze Weichgewebe

Halfpunch for Softtissue
 Estampa media per tejido
 Semistance ppour tissu
 Semipunzonatri tessuto

Iglhaut 43-900-01 - 43-900-04

Distanzhalter T-Form
 Distancemount, T-shape
 Distanciador, T-forma
 Distancecadre, T-forme
 Sosteng. dista. T-Forma

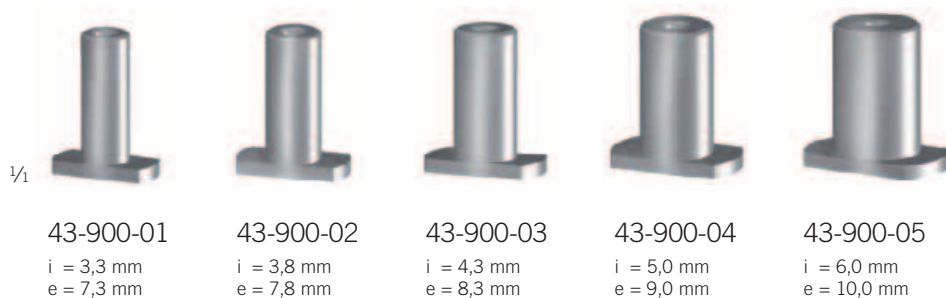

1/1

43-900-01 i = 3,3 mm e = 7,3 mm	43-900-02 i = 3,8 mm e = 7,8 mm	43-900-03 i = 4,3 mm e = 8,3 mm	43-900-04 i = 5,0 mm e = 9,0 mm	43-900-05 i = 6,0 mm e = 10,0 mm
---------------------------------------	---------------------------------------	---------------------------------------	---------------------------------------	--

Iglhaut 43-910-01 - 43-910-04

Distanzhalter L-Form
 Distancemount, L-shape
 Distanciador, L-forma
 Distancecadre, L-forme
 Sosteng. dista. L-Forma

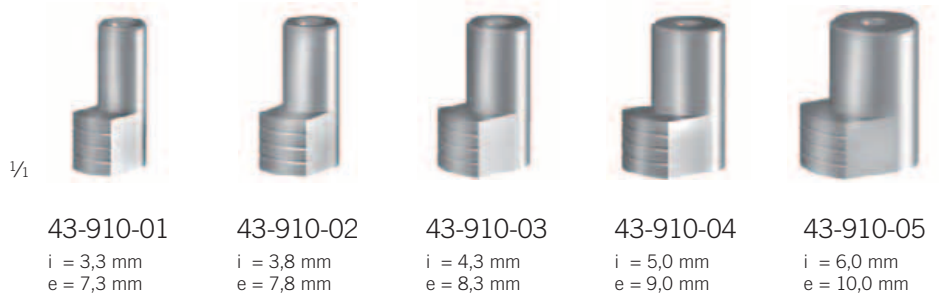

1/1

43-910-01 i = 3,3 mm e = 7,3 mm	43-910-02 i = 3,8 mm e = 7,8 mm	43-910-03 i = 4,3 mm e = 8,3 mm	43-910-04 i = 5,0 mm e = 9,0 mm	43-910-05 i = 6,0 mm e = 10,0 mm
---------------------------------------	---------------------------------------	---------------------------------------	---------------------------------------	--

Iglhaut 38-010-01 - 38-010-05

Halbstanze Weichgewebe
 Halfpunch for Softtissue
 Estampa media per tejido
 Semistance ppour tissu
 Semipunzonatri tessuto

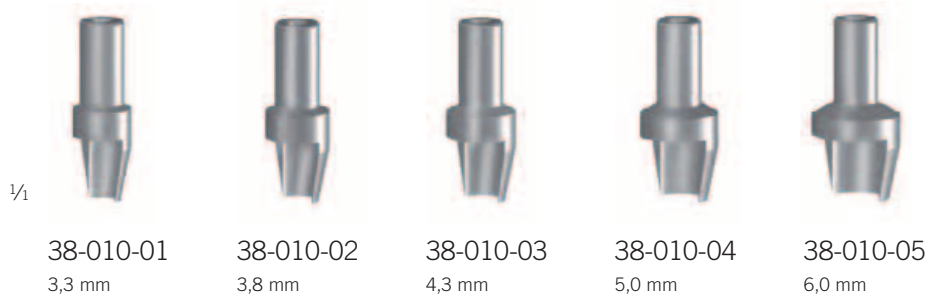

1/1

38-010-01 3,3 mm	38-010-02 3,8 mm	38-010-03 4,3 mm	38-010-04 5,0 mm	38-010-05 6,0 mm
---------------------	---------------------	---------------------	---------------------	---------------------



1/1

Iglhaut
 43-950-01
 Fixierstift
 Fixing pin
 Pin para fijado
 Pin pour fixer
 Chiodo per fissaggio



Osteotome

Osteotomes
Osteótomos
Ostéotomes
Osteotomi

Knocheninstrumente

Bone instruments
Instrumentos para hueso
Instruments à l'os
Strumenti per osso

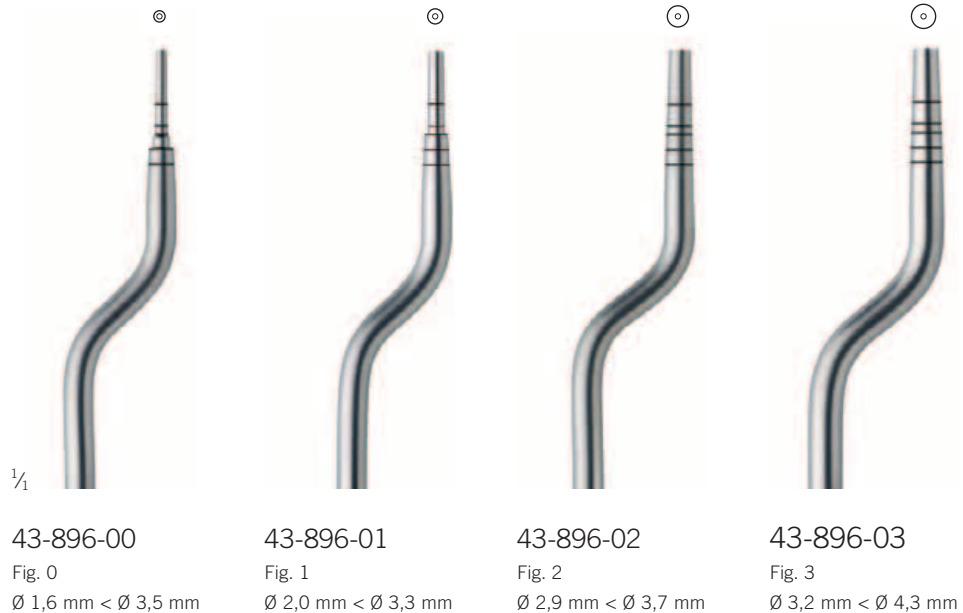
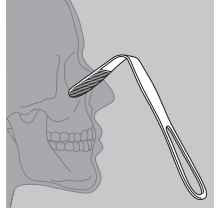

Körner-Westermann
43-896-00 - 43-896-03

17,5 cm / 6 7/8"

konkaves Arbeitsende
für die Sinusboden-Elevation,
graduier 7 - 10 - 11 - 13 - 15 mm

concave working end
for sinus floor elevation,
graduated 7 - 10 - 11 - 13 - 15 mm

punta de trabajo cóncava
para elevar el piso del seno,
graduado 7 - 10 - 11 - 13 - 15 mm

extrémité opératoire concave
pour élévation du fond de sinus,
gradué 7 - 10 - 11 - 13 - 15 mm

estremità di lavoro concava
per l'elevazione della base sinusale,
graduato 7 - 10 - 11 - 13 - 15 mm

Osteotome

Osteotomes

Osteótomos

Ostéotomes

Osteotomi



1/4

43-897-00

Fig. 0X

Ø 1,3 mm < Ø 2,8 mm



43-897-01

Fig. 1X

Ø 2,0 mm < Ø 5,0 mm



43-897-02

Fig. 2X

Ø 2,5 mm < Ø 5,0 mm



43-897-03

Fig. 3X

Ø 4,0 mm < Ø 5,0 mm



1/2

Körner-Westermann
43-897-00 - 43-897-03

17,5 cm / 6 7/8"

konvexes Arbeitsende
für die Sinusboden-Elevation,
graduieret 7 - 10 - 11 - 13 - 15 mm

convex working end
for sinus floor elevation,
graduated 7 - 10 - 11 - 13 - 15 mm

punta de trabajo convexa
para elevar el piso del seno,
graduado 7 - 10 - 11 - 13 - 15 mm

extrémité opératoire convexe
pour élévation du fond de sinus,
gradué 7 - 10 - 11 - 13 - 15 mm

estremità di lavoro convessa
per l'elevazione della base sinusale,
graduato 7 - 10 - 11 - 13 - 15 mm

Knochenspreizer

Bone spreaders
 Separadores de huesos
 Séparateurs d'os
 Separatori per ossa

Knocheninstrumente

Bone instruments
 Instrumentos para hueso
 Instruments à l'os
 Strumenti per osso

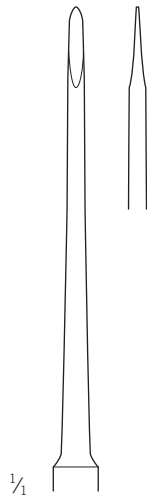
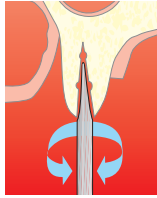
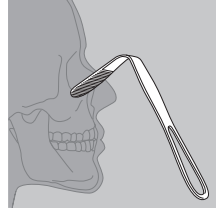

43-899-01
 Fig. 1
 1,6/2,2 mm
 gerade
 straight
 recto
 droit
 diritto

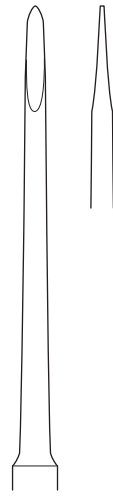

43-899-02
 Fig. 2
 2,2/2,8 mm
 gerade
 straight
 recto
 droit
 diritto

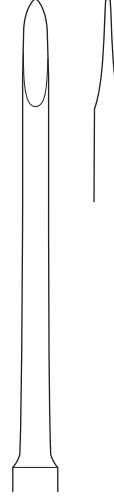

43-899-03
 Fig. 3
 2,8/3,4 mm
 gerade
 straight
 recto
 droit
 diritto



43-899-04
 Fig. 4
 3,4/4,0 mm
 gerade
 straight
 recto
 droit
 diritto

43-899-01 - 43-899-04
 17,5 cm / 6 7/8"

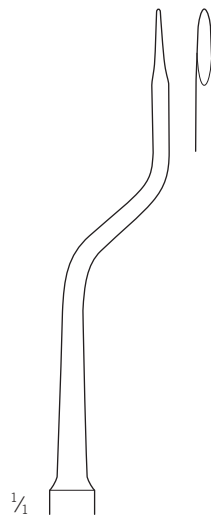
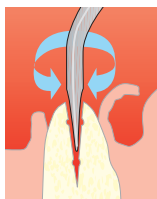

43-899-11
 Fig. 1B
 1,6/2,2 mm
 bajonett
 bayonet
 bayoneta
 baïonnette
 bajonetta

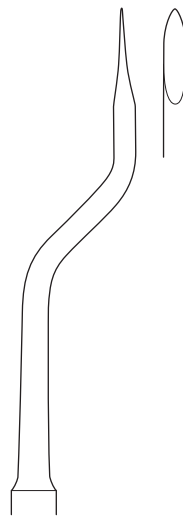

43-899-22
 Fig. 2B
 2,2/2,8 mm
 bajonett
 bayonet
 bayoneta
 baïonnette
 bajonetta

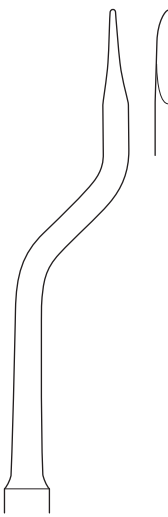

43-899-33
 Fig. 3B
 2,8/3,4 mm
 bajonett
 bayonet
 bayoneta
 baïonnette
 bajonetta

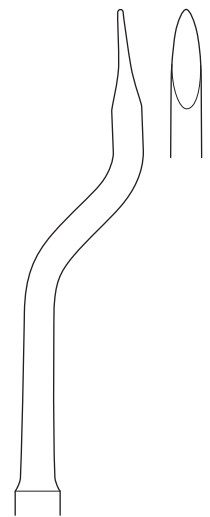

43-899-44
 Fig. 4B
 3,4/4,0 mm
 bajonett
 bayonet
 bayoneta
 baïonnette
 bajonetta

43-899-11 - 43-899-44
 17,5 cm / 6 7/8"

Dilatatoren

Dilatators
Dilatadores
Dilatateurs
Dilatatori

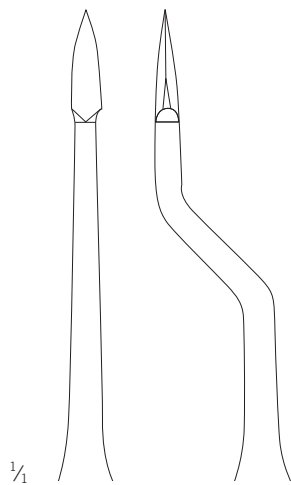

43-610-01

Fig. 1

3,8 x 13 mm

ohne Graduierung
w/o graduation
sin graduación
sans graduation
senza graduazione



1/2

Iglhaut
43-610-01
17,5 cm / 6 7/8"

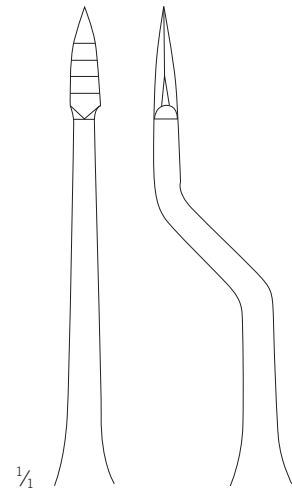

43-610-02

Fig. 2

4,0 x 11 mm

mit Graduierung
with graduation
con graduación
avec graduation
con graduazione



1/2

Iglhaut
43-610-02
17,5 cm / 6 7/8"



Mund-, Kiefer- und Gesichtschirurgie

Oral and Craniomaxillofacial surgery

Cirugía oral y maxilofacial

Chirurgie orale et maxillofaciale

Chirurgia orale e maxillofacciale

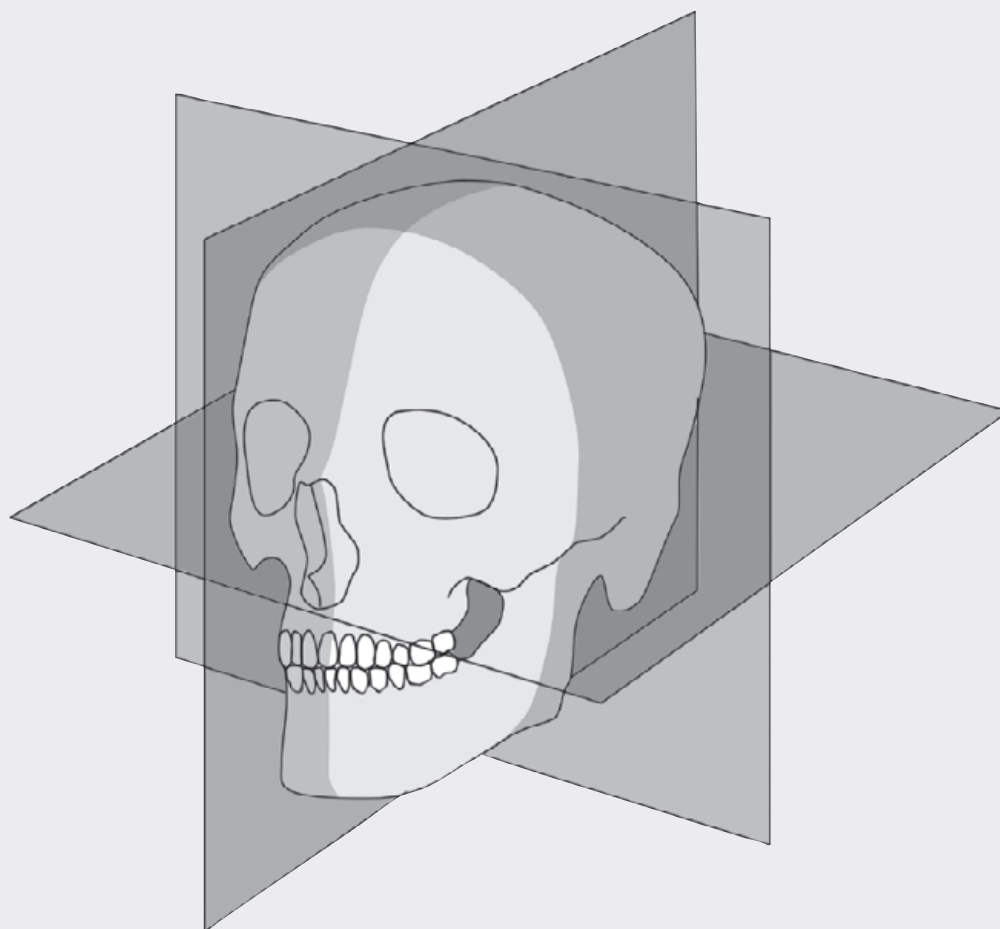

Mund-, Kiefer- und Gesichtschirurgie



Mit der Entwicklung der Miniplatten-Osteosynthese hat alles begonnen. Heute gilt der revolutionäre Ansatz von KLS Martin als Golden Standard. Viele weitere neue Behandlungsmethoden, zusammen mit führenden Anwendern aus aller Welt entwickelt, haben KLS Martin zum Innovationsführer und in vielen Bereichen zu einem führenden Anbieter von Lösungen in der Mund-, Kiefer- und Gesichtschirurgie gemacht. Wissenschaftlich begleitet wurden viele Projekte von der renommierten S.O.R.G.-Gruppe aus Straßburg.



GB

Oral and maxillofacial surgery

It all began with the development of miniplate osteosynthesis. Meanwhile, KLS Martin's revolutionary approach has become 'the' standard method. Together with many other new treatment methods, developed in co-operation with leading users in all parts of the globe, have made KLS Martin the leading innovator and, in many areas, a leading provider of solutions for oral, maxillary and facial surgery. Many of these projects were made possible by the scientific assistance provided by the highly respected S.O.R.G. Group of Strasbourg.

ES

Cirugía oral y maxilofacial

Todo empezó con el desarrollo de la osteosíntesis con mini placas. Actualmente, la revolucionaria idea de KLS Martin se considera como el "patrón oro" o "golden standard". Otros muchos nuevos métodos terapéuticos, desarrollados en colaboración con usuarios líderes de todos los rincones del mundo, han convertido a KLS Martin en un líder en lo que innovaciones respecta y, en muchos sectores, también en un proveedor líder de soluciones para la cirugía facial oromaxilar. En numerosos proyectos han participado científicos pertenecientes al prestigioso grupo S.O.R.G. de Estrasburgo.

F

Chirurgie maxillo-faciale

Tout a commencé par le développement des mini-plaques pour ostéosynthèse. La conception révolutionnaire de KLS Martin est, de nos jours, considérée comme un « Golden Standard ». De nombreuses autres nouvelles méthodes de soins, développées en commun avec des utilisateurs leaders dans le monde entier, ont fait de KLS Martin un pionnier en matière d'innovations et dans de nombreux domaines, et également un fournisseur de premier plan concernant les solutions destinées au secteur de la chirurgie maxillo-faciale. De nombreux projets ont été accompagnés scientifiquement par le groupe renommé S.O.R.G., implanté à Strasbourg.

I

Chirurgia orale e maxillo-facciale

Tutto è cominciato dallo sviluppo dell'osteosintesi con mini-placche; oggi giorno questa rivoluzionaria applicazione di KLS Martin rappresenta il „Golden Standard“. Tanti nuovi metodi di trattamento, sviluppati in collaborazione con leader del settore su scala mondiale, hanno reso la KLS Martin il leader d'innovazione ed, in molti settori, il leader assoluto nell'offerta di soluzioni per la chirurgia orale e maxillo-facciale. Dal punto di vista tecnico e scientifico molti progetti sono stati seguiti dal rinomato gruppo S.O.R.G. di Strasbourg.

TRACK 1,0-mm-Distraktoren

TRACK 1.0 mm Distractors
Distractores TRACK 1,0 mm
Distracteurs TRACK 1,0 mm
Distrattori TRACK 1,0 mm

Micro TRACK

Indikationen

- Einzelzahnsegmente des Alveolarkamms
- Zahnankylose

Einsatz mit Mikro-Schrauben 1,0 mm

1 Drehung = 0,3 mm

Indications

- single tooth segments of the alveolar ridge
- ankylosed teeth

To be used with micro screws 1.0 mm

1 turn = 0.3 mm

Indicaciones

- segmentos de un sólo diente de la cresta alveolar
- dientes anquilosados

Se utilizará con tornillos micro de 1,0 mm

1 vuelta = 0,3 mm

Indications

- segment à une dent de la crête alvéolaire
- dents ankylosées

A utiliser avec des vis micro de 1,0 mm

1 rotation = 0,3 mm

Indicazioni

- singoli segmenti dentellati della cresta alveolare
- dente anchilosato

Da usare con viti micro da 1,0 mm

1 giro = 0,3 mm

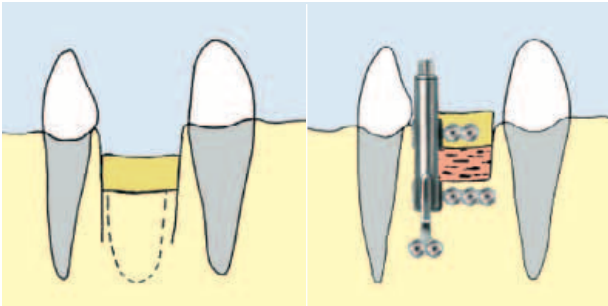

51-523-06 Ti

Micro TRACK

Distraktionslänge
Distraction length
Longitud de distracción
Longueur de distraction
Lunghezza di distrazione
6 mm



51-523-09 Ti

Micro TRACK

Distraktionslänge
Distraction length
Longitud de distracción
Longueur de distraction
Lunghezza di distrazione
9 mm



51-523-12 Ti

Micro TRACK

Distraktionslänge
Distraction length
Longitud de distracción
Longueur de distraction
Lunghezza di distrazione
12 mm

Bitte beachten:
Zum Schutz der Schweißzone empfehlen wir die Verwendung der Biegezangen 25-486-13 und 51-525-76. Siehe Seite 181.

Please note:
In order to protect the welding zone we recommend to use the bending pliers 25-486-13 and 51-525-76. See page 181.

Rogamos que observe:
para proteger la zona de soldadura, recomendamos que utilice los alicates de moldeado 25-486-13 y los alicates de sujeción del distractor 51-525-76. Véase página 181.

Note:
afin d'assurer la protection de la zone de soudage, nous recommandons l'utilisation des pinces de pliage 25-486-13 et 51-525-76. Voir page 181.

Avvertenza:
al fine di proteggere l'area di saldatura consigliamo l'uso delle pinze piegaplacche 25-486-13 e 51-525-76. Vedi pagina 181.

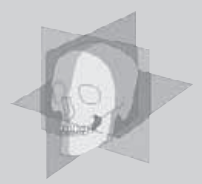

TRACK 1.0 mm

Indikationen

- Kleinere Partialdefekte im Alveolarkamm des Ober- oder Unterkiefers

Einsatz mit Mikro-Schrauben 1,0 mm

1 Drehung = 0,3 mm

Indications

- smaller partial defects of the maxillary and mandibular alveolar ridge

To be used with micro screws 1.0 mm

1 turn = 0.3 mm

Indicaciones

- defectos parciales menores de la cresta alveolar maxilar y mandibular

Se utilizará con tornillos micro de 1,0 mm

1 vuelta = 0,3 mm

Indications

- petits défauts partiels de la crête alvéolaire maxillaire et mandibulaire

A utiliser avec des vis micro de 1,0 mm

1 rotation = 0,3 mm

Indicazioni

- minori difetti parziali della cresta alveolare mascellare e mandibolare

Da usare con viti micro da 1,0 mm

1 giro = 0,3 mm



Defekt, präoperativ
Defect, pre-operative
Defecto, antes de la operación
Défaut, avant l'opération
Difetto preoperatorio

Distraktor während der Aktivierungsphase
Distractor during the activation phase
Distractor durante la fase de activación
Distracteur pendant la phase de activation
Distrattore durante la fase di attivazione

Konsolidierungsphase
Consolidation phase
Fase de consolidación
Phase de consolidation
Fase di consolidamento

Nach Einbringung des Implantats
After implant placement
Después de la colocación del implante
Après la mise en place de l'implant
Dopo la collocazione dell'implianto

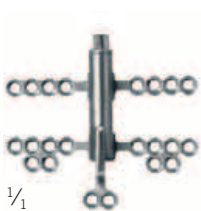

1/1

51-525-06 Ti

TRACK 1.0

Distraktionslänge
Distraction length
Longitud de distracción
Longueur de distraction
Lunghezza di distrazione
6 mm



51-525-09 Ti

TRACK 1.0

Distraktionslänge
Distraction length
Longitud de distracción
Longueur de distraction
Lunghezza di distrazione
9 mm

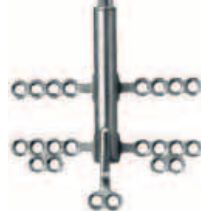

51-525-12 Ti

TRACK 1.0

Distraktionslänge
Distraction length
Longitud de distracción
Longueur de distraction
Lunghezza di distrazione
12 mm



51-525-15 Ti

TRACK 1.0

Distraktionslänge
Distraction length
Longitud de distracción
Longueur de distraction
Lunghezza di distrazione
15 mm

Bitte beachten:
Zum Schutz der Schweißzone empfehlen wir die Verwendung der Biegezangen 25-486-13 und 51-525-76. Siehe Seite 181.

Please note:
In order to protect the welding zone we recommend using the bending pliers 25-486-13 and 51-525-76. See page 181.























Rogamos que observe:
para proteger la zona de soldadura, recomendamos que utilice los alicates de moldeado 25-486-13 y los alicates de sujeción del distractor 51-525-76. Véase página 181.

Note:
afin d'assurer la protection de la zone de soudage, nous recommandons l'utilisation des pinces de pliage 25-486-13 et 51-525-76. Voir page 181.

Avvertenza:
al fine di proteggere l'area di saldatura consigliamo l'uso delle pinze piegaplacche 25-486-13 e 51-525-76. Vedi pagina 181.

TRACK 1,0-mm-Distraktoren

TRACK 1.0 mm Distractors
 Distractores TRACK 1,0 mm
 Distracteurs TRACK 1,0 mm
 Distrattori TRACK 1,0 mm

Centre Drive®		Cross Drive	
selbsthaltend/self-retaining/autobloqueantes/ autobloquante/autoritensiva			
Mikro-Schrauben/Micro Screws/Tornillos Micro/ Vis Micro/Viti Micro			
			
1.0 x 4 mm	25-660-04  	25-670-04  	
1.0 x 5 mm	25-660-05  	25-670-05  	
1.0 x 6 mm	25-660-06  	25-670-06  	
Notfallschrauben/Emergency Screws/Tornillos de emergencia/Vis d'urgence/Viti di emergenza			
			
1.2 x 5 mm	25-661-05  	25-671-05  	



25-650-01

Messclip für Schraubenlänge, blau
 Measuring clip for screw length, blue
 Clip de medición para longitud de tornillos, azul
 Jauge de longueur de vis, bleue
 Clip di misurazione per la lunghezza della vite, blu



25-651-01

Messclip für Schraubendurchmesser
 Measuring clip for screw diameter
 Clip de medición para diámetro de tornillo
 Jauge de diamètre de vis
 Clip di misurazione per il diametro della vite





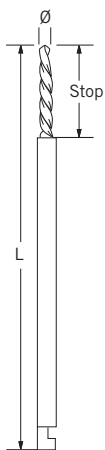

Vorbohrer
 Twist drills
Brocas
 Mèches de préforage
Frese



**Stryker-Ansatz, Stryker attachment, Sujeción tipo
 Stryker, Embout Stryker, Connessione Stryker**



Ø x L (mm) Stop (mm)

0.7 x 50	3	25-454-03	 
0.7 x 50	3	25-454-03-91	 
0.7 x 50	5	25-454-05	 
0.7 x 50	5	25-454-05-91	 
0.7 x 50	7	25-454-07	 
0.7 x 50	7	25-454-07-91	 













für dichten Knochen/for dense bone/para hueso
 densos/pour os dense/per ossa spesse

0.8 x 50	5	25-457-05	 
0.8 x 50	5	25-457-05-91	 
0.8 x 50	7	25-457-07-91	 



**Zylindrischer Ansatz, cylindrical attachment, Sujeción
 tipo cilíndrico, Embout cylindrique, Connessione cilindrica**

Ø x L (mm) Stop (mm)

0.7 x 50	3	25-453-03	 
0.7 x 50	3	25-453-03-91	 
0.7 x 50	5	25-453-05	 
0.7 x 50	5	25-453-05-91	 
0.7 x 50	7	25-453-07	 
0.7 x 50	7	25-453-07-91	 

für dichten Knochen/for dense bone/para huesos
 densos/pour os dense/per ossa spesse

0.8 x 50	5	25-455-05	 
0.8 x 50	5	25-455-05-91	 
0.8 x 50	7	25-455-07-91	 

Schraubendreher und Funktionsteile
Screwdrivers and Blades
Destornilladores y terminales
Tournevis et lames
Cacciaviti e lame





Funktionsteile passend für
 Blades suitable for
 Mechas apropiadas para
 Lames pour
 Lame adatte per

25-480-99 25-402-99

25-492-98		1.0 mm	x
25-428-98		1.0 mm	x
25-493-98		1.0 mm	x
25-429-98		1.0 mm	x

Festdreh-Schraubendreher
Fixation Screwdrivers
Destornilladores de fijación
Tournevis de fixation
Cacciaviti per fissaggio

25-494-13		1.0 mm
25-432-16		1.5 mm

Bone-Graft-Schraubendreher
Bone Graft Screwdrivers
Destornilladores Bone Graft
Tournevis pour extraire la spongieuse Bone Graft
Cacciaviti Bone Graft

25-422-10		1.0 mm
25-423-10		1.0 mm
25-422-15		1.5 mm
25-423-15		1.5 mm





51-525-85

Patientenschraubendreher, gerade
Patient screwdriver, straight
Destornillador del paciente, recto
Tournevis patient, droit
Cacciavite per paziente, diritto

51-525-90

Patientenschraubendreher, Kombination gerade + abgewinkelt
Patient screwdriver, combination straight + angled
Destornillador del paciente, combinación recto y articulado
Tournevis patient, combinaison de tournevis patient droit + courbe
Cacciavite per paziente, combinazione diritto + ricurvo

51-525-95

Patientenschraubendreher, mikro
Patient screwdriver, micro
Destornillador del paciente, micro
Tournevis patient, micro
Cacciavite per paziente, micro

Lindorf
25-435-10

16 cm / 6 2/8"
Platten-Halteinstrument
Plate-holding instrument
Instrumento para sujetar placas
Pince à saisir les plaques
Strumento di presa per placche

51-525-80

16 cm / 6 2/8"
Platten-Fassspinzette, gebogen
Plate-holding forceps, curved
Pinza para sujetar placas, curvada
Pince à saisir les plaques, courbe
Pinza di presa per placche, curva

TC GOLD

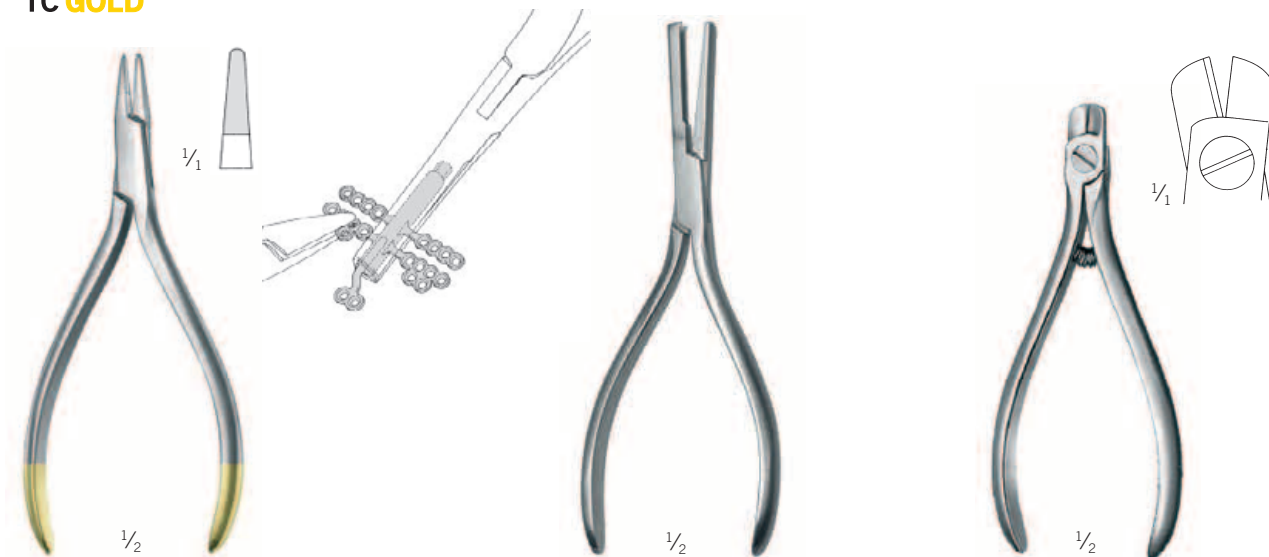

25-486-13

13 cm / 5 1/8"

Modellierzange
Modeling pliers
Alicates de moldeado
Pince à modeler
Pinza modellante

51-525-76

13 cm / 5 1/8"

Distraktor-Haltezange für Micro TRACK und TRACK 1,0 mm
Distractor holding plier for Micro TRACK and TRACK 1.0 mm
Alicates de sujeción del distractor para Micro TRACK y TRACK 1,0 mm
Pince à saisir les distracteurs pour Micro TRACK et TRACK 1,0 mm
Pinza per tenuta distrattore per Micro TRACK e TRACK da 1,0 mm

25-490-11

12 cm / 4 6/8"

Plattenschneidezange
Plate cutter
Alicates de corte para planchas
Pince coupante pour plaques
Pinza per taglio di placche

TRACK 1Plus-Distraktoren / TRACK 1,5-mm-Distraktoren

TRACK 1Plus Distractors / TRACK 1.5 mm Distractors
 Distractores TRACK 1Plus / Distractores TRACK 1,5 mm
 Distracteurs TRACK 1Plus / Distracteurs TRACK 1,5 mm
 Distrattori TRACK 1Plus / Distrattori TRACK 1,5 mm

TRACK 1Plus

Indikationen

- Alveolarkammsegmente, max. Breite 3-4 Zähne (35 mm)

Einsatz mit Mikro-Schrauben 1,5 mm

1 Drehung = 0,3 mm

Indications

- up to 3-4 teeth (35 mm) segments of the alveolar ridge

To be used with micro screws 1.5 mm

1 turn = 0.3 mm

Indicaciones

- hasta segmentos de 3-4 dientes (35 mm) de la cresta alveolar

Se utilizará con tornillos micro de 1,5 mm

1 vuelta = 0,3 mm

Indications

- segments jusqu'à 3 à 4 dents (35 mm) de la crête alvéolaire

A utiliser avec des vis Micro de 1,5 mm

1 rotation = 0,3 mm

Indicazioni

- fino a 3-4 singoli segmenti dentellati (35 mm) della cresta alveolare

Da usare con viti micro da 1,5 mm

1 giro = 0,3 mm

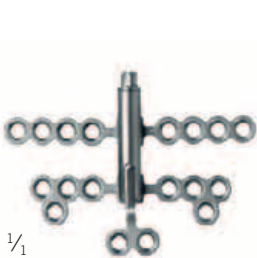
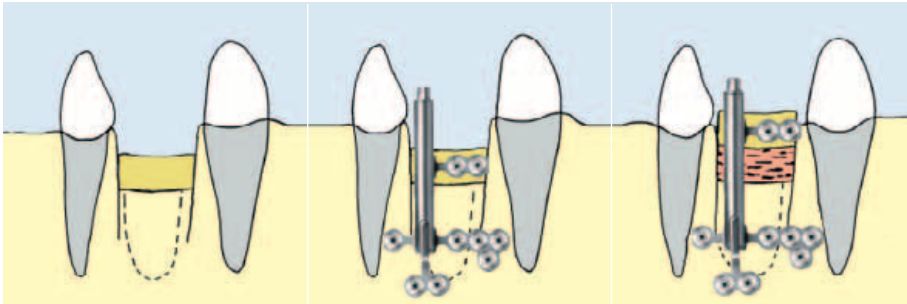

1/1

51-524-06 

TRACK 1Plus

Distraktionslänge
 Distraction length
 Longitud de distracción
 Longueur de distraction
 Lunghezza di distrazione

6 mm



51-524-09 

TRACK 1Plus

Distraktionslänge
 Distraction length
 Longitud de distracción
 Longueur de distraction
 Lunghezza di distrazione

9 mm



51-524-12 

TRACK 1Plus

Distraktionslänge
 Distraction length
 Longitud de distracción
 Longueur de distraction
 Lunghezza di distrazione

12 mm



51-524-15 

TRACK 1Plus

Distraktionslänge
 Distraction length
 Longitud de distracción
 Longueur de distraction
 Lunghezza di distrazione

15 mm

Bitte beachten:
 Zum Schutz der Schweißzone empfehlen wir die Verwendung der Biegezangen 25-486-13 und 51-525-76. Siehe Seite 187.

Please note:
 In order to protect the welding zone we recommend using the bending pliers 25-486-13 and 51-525-76. See page 187.

Rogamos que observe:
 Para proteger la zona de soldadura, recomendamos la utilización de los alicates de moldeado 25-486-13 y los alicates de sujeción del distractor 51-525-76. Véase página 187.

Note :
 afin d'assurer la protection de la zone de soudage, nous recommandons l'utilisation des pinces de pliage 25-486-13 et 51-525-76. Voir page 187.

Avvertenza:
 al fine di proteggere l'area di saldatura consigliamo l'uso delle pinze piegaplacche 25-486-13 e 51-525-76. Vedi pagina 187.

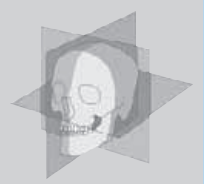

TRACK 1.5 mm

Indikationen

- Größere Atrophien (bis 60 mm Breite)

Einsatz mit Mikro-Schrauben 1,0 mm

1 Drehung = 0,3 mm

Indications

- wide atrophies up to 60 mm width

To be used with micro screws 1.0 mm

1 turn = 0.3 mm

Indicaciones

- atroñas de gran tamaño de hasta 60 mm de anchura

Se utilizará con tornillos micro de 1,0 mm

1 vuelta = 0,3 mm

Indications

- atrophies larges jusqu'à 60 mm de largeur

A utiliser avec des vis micro de 1,0 mm

1 rotation = 0,3 mm

Indicazioni

- ampie atrofie fino a 60 mm di ampiezza

Da usare con viti micro da 1,0 mm

1 giro = 0,3 mm

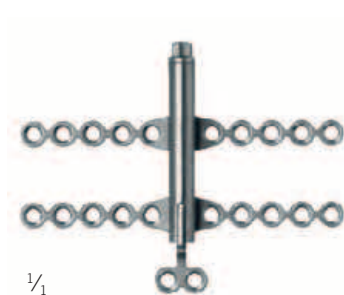
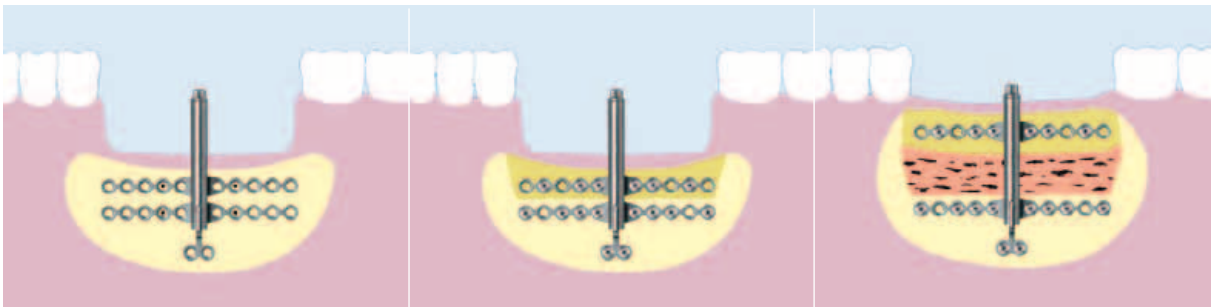

1/1

51-520-10 Ti

TRACK 1.5

Distraktionslänge
Distraction length
Longitud de distracción
Longueur de distraction
Lunghezza di distrazione
10 mm

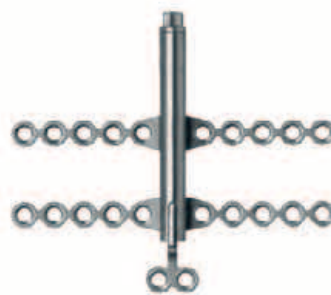

51-520-15 Ti

TRACK 1.5

Distraktionslänge
Distraction length
Longitud de distracción
Longueur de distraction
Lunghezza di distrazione
15 mm

Bitte beachten:
Zum Schutz der Schweißzone empfehlen wir die Verwendung der Biegezangen 25-486-13 und 51-520-70. Siehe Seite 187.

Please note:
In order to protect the welding zone we recommend using the bending pliers 25-486-13 and 51-520-70. See page 187.













































Rogamos que observe:
Para proteger la zona de soldadura, recomendamos la utilización de los alicates de moldeado 25-486-13 y los alicates de sujeción del distractor 51-520-70. Véase página 187.

Note :
afin d'assurer la protection de la zone de soudage, nous recommandons l'utilisation des pinces de pliage 25-486-13 et 51-520-70. Voir page 187.

Avvertenza:
al fine di proteggere l'area di saldatura consigliamo l'uso delle pinze piegaplacche 25-486-13 e 51-520-70. Vedi pagina 187.

TRACK 1Plus-Distraktoren / TRACK 1,5-mm-Distraktoren

TRACK 1Plus Distractors / TRACK 1.5 mm Distractors
 Distractores TRACK 1Plus / Distractores TRACK 1,5 mm
 Distracteurs TRACK 1Plus / Distracteurs TRACK 1,5 mm
 Distrattori TRACK 1Plus / Distrattori TRACK 1,5 mm

Centre Drive®		Cross Drive	
selbsthaltend/self-retaining/autobloqueantes/ autobloquante/autoritensiva			
Mikro-Schrauben/Micro Screws/Tornillos Micro/ Vis Micro/Viti Micro			
			
1.5 x 4 mm	25-665-04  	25-675-04  	
1.5 x 5 mm	25-665-05  	25-675-05  	
1.5 x 6 mm	25-665-06  	25-675-06  	
1.5 x 7 mm	25-665-07  	25-675-07  	
Notfallschrauben/Emergency Screws/ Tornillos de emergencia/Vis d'urgence/Viti di emergenza			
			
1.8 x 5 mm	25-666-05  	25-676-05  	
1.8 x 7 mm	25-666-07  	25-676-07  	
Drill-Free-Schrauben/Drill-Free Screws/Tornillos Drill-Free/ Vis Drill-Free autotaraudeuses/Viti Drill-Free autoporanti			
			
1.5 x 4 mm	25-668-04  	25-678-04  	
1.5 x 5 mm	25-668-05  	25-678-05  	
1.5 x 6 mm	25-668-06  	25-678-06  	



25-650-02

Messclip für Schraubenlänge, grün
 Measuring clip for screw length, green
 Clip de medición para longitud de tornillos, verde
 Jauge de longueur de vis, verte
 Clip di misurazione per la lunghezza della vite, verde



25-651-01

Messclip für Schraubendurchmesser
 Measuring clip for screw diameter
 Clip de medición para diámetro de tornillo
 Jauge de diamètre de vis
 Clip di misurazione per il diametro della vite







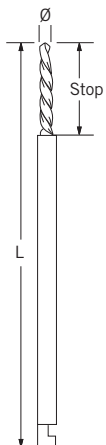





Vorbohrer Twist drills Brocas Mèches de préforage Frese



Stryker-Ansatz, Stryker attachment, Sujeción tipo Stryker, Embout Stryker, Connessione Stryker















Ø x L (mm) Stop (mm)

1.1 x 50	–	25-452-00	 
1.1 x 50	–	25-452-00-91	 
1.1 x 50	5	25-452-05	 
1.1 x 50	5	25-452-05-91	 
1.1 x 50	7	25-452-07	 
1.1 x 50	7	25-452-07-91	 



Zylindrischer Ansatz, cylindrical attachment, Sujeción tipo cilíndrico, Embout cylindrique, Connessione cilindrica

Ø x L (mm) Stop (mm)

1.1 x 50	–	25-451-00	 
1.1 x 50	–	25-451-00-91	 
1.1 x 50	5	25-451-05	 
1.1 x 50	5	25-451-05-91	 
1.1 x 50	7	25-451-07	 
1.1 x 50	7	25-451-07-91	 

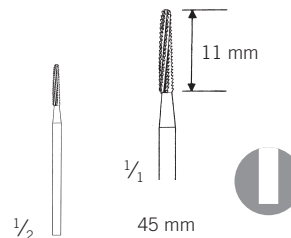

38-051-45

Fräse
 Milling cutter
 Broca para taladros previos
 Fraise
 Fresa

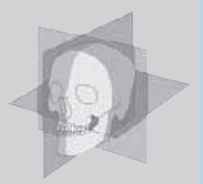

Schraubendreher und Funktionsteile
Screwdrivers and Blades
Destornilladores y terminales
Tournevis et lames
Cacciaviti e lame



Funktionsteile passend für
 Blades suitable for
 Mechas apropiadas para
 Lames pour
 Lame adatte per

25-480-99 25-402-99

25-431-98	⊖	1.5 mm	x	
25-430-98	⊖	1.5 mm		x
25-432-98	⊕	1.5 mm	x	
25-483-97	⊕	1.5 mm		x

Festreh-Schraubendreher
Fixation Screwdrivers
Destornilladores de fijación
Tournevis de fixation
Cacciaviti per fissaggio



25-432-16	⊖	1.5 mm		
25-483-13	⊕	1.5 mm		

Bone-Graft-Schraubendreher
Bone Graft Screwdrivers
Destornilladores Bone Graft
Tournevis pour extraire la spongieuse Bone Graft
Cacciaviti Bone Graft



25-422-15	⊖	1.5 mm		
25-423-15	⊕	1.5 mm		

TRACK 1Plus-Distraktoren / TRACK 1,5-mm-Distraktoren

TRACK 1Plus Distractors / TRACK 1.5 mm Distractors

Distractores TRACK 1Plus / Distractores TRACK 1,5 mm

Distracteurs TRACK 1Plus / Distracteurs TRACK 1,5 mm

Distrattori TRACK 1Plus / Distrattori TRACK 1,5 mm



1/2

51-525-85

Patientenschraubendreher, gerade, für TRACK 1Plus
 Patient screwdriver, straight, for TRACK 1Plus
 Destornillador del paciente, recto, para TRACK 1Plus
 Tournevis patient, droit, pour TRACK 1Plus
 Cacciavite per paziente, diritto, per TRACK 1Plus



1/2

51-525-90

Patientenschraubendreher,
 Kombination gerade + abgewinkelt für TRACK 1Plus
 Patient screwdriver, combination straight + angled
 for TRACK 1Plus
 Destornillador del paciente,
 combinación recto y articulado para TRACK 1Plus
 Tournevis patient,
 combinaison droit + courbe pour TRACK 1Plus
 Cacciavite per paziente,
 combinazione diritto + ricurvo per TRACK 1Plus



1/2

51-525-95

Patientenschraubendreher, mikro, für TRACK 1Plus
 Patient screwdriver, micro, for TRACK 1Plus
 Destornillador del paciente, micro, para TRACK 1Plus
 Tournevis patient, micro, pour TRACK 1Plus
 Cacciavite per paziente, micro, per TRACK 1Plus



1/2

51-500-90

Patientenschraubendreher, gerade, für TRACK 1,5 mm
 Patient screwdriver, straight, for TRACK 1.5 mm
 Destornillador del paciente, recto, para TRACK 1,5 mm
 Tournevis patient, droit, pour TRACK 1,5 mm
 Cacciavite per paziente, diritto, per TRACK da 1,5 mm



1/2

51-505-90

Patientenschraubendreher, abgewinkelt, für TRACK 1,5 mm
 Patient screwdriver, angled, for TRACK 1.5 mm
 Destornillador del paciente, articulado, para TRACK 1,5 mm
 Tournevis patient, courbe, pour TRACK 1,5 mm
 Cacciavite per paziente, ricurvo, per TRACK da 1,5 mm



1/2

51-520-95

Patientenschraubendreher, mikro, für TRACK 1,5 mm
 Patient screwdriver, micro, for TRACK 1.5 mm
 Destornillador del paciente, micro, para TRACK 1,5 mm
 Tournevis patient, micro, pour TRACK 1,5 mm
 Cacciavite per paziente, micro, per TRACK da 1,5 mm

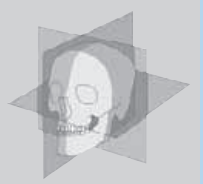

Lindorf
25-435-15
18 cm / 7 1/8"

Platten-Halteinstrument
Plate-holding instrument
Instrumento para sujetar placas
Instrument à saisir les plaques
Strumento di presa per placche



51-525-80
15,5 cm / 6 1/8"

Platten-Fasspinzette, gebogen
Plate-holding forceps, curved
Pinza para sujetar placas, curvada
Pince à saisir les plaques, courbe
Pinza di presa per placche, curva

TC GOLD



25-486-13
13 cm / 5 1/8"

Modellierzange
Modeling pliers
Alicates de moldeado
Pince à modeler
Pinza modellante



51-525-76
13 cm / 5 1/8"

Distraktor-Haltezange für TRACK 1Plus
Distractor holding plier for TRACK 1Plus
Alicates de sujeción del distractor para TRACK 1Plus
Pince à saisir les distracteurs pour TRACK 1Plus
Pinza per tenuta distrattore per TRACK 1Plus



51-520-70
13 cm / 5 1/8"

Distraktor-Haltezange für TRACK 1,5 mm
Distractor holding plier for TRACK 1.5 mm
Alicates de sujeción del distractor para TRACK 1,5 mm
Pince à saisir les distracteurs pour TRACK 1,5 mm
Pinza per tenuta distrattore per TRACK da 1,5 mm

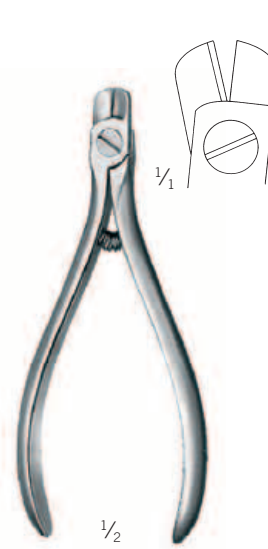

25-490-11
12 cm / 4 5/8"

Plattenschneidezange
Plate cutter
Alicates de corte para planchas
Pince coupante pour plaques
Pinza per taglio di placche

TRACK 2,0-mm-Distraktoren

TRACK 2.0 mm Distractors

Distractores TRACK 2,0 mm

Distracteurs TRACK 2,0 mm

Distrattori TRACK 2,0 mm

TRACK 2.0 mm

Indikationen

- Hoch atropher und zahnloser Unterkiefer, vorderer Bereich

Einsatz mit Mikro-Schrauben 1,5 mm bei Transportplatte und Mini-Schrauben 2,0 mm bei Grundplatte

1 Drehung = 0,5 mm

Indications

- highly atrophic and edentulous mandibles in the front section

To be used with micro screws 1.5 mm for the transport plate and mini screws 2.0 mm for the base plate

1 turn = 0.5 mm

Indicaciones

- mandíbulas altamente atroficas y sin dientes en la sección frontal

Debe utilizarse con tornillos micro de 1,5 mm para la placa de transporte y tornillos mini de 2,0 mm para la placa base

1 vuelta = 0,5 mm

Indications

- Mandibules très atrophiées et édentées dans la partie frontale

A utiliser avec des vis micro de 1,5 mm pour la plaque de transport et des vis Mini de 2,0 mm pour la plaque de base

1 rotation = 0,5 mm

Indicazioni

- mandibole altamente atrofiche ed edentule nella sezione frontale

Da usare con viti micro da 1,5 mm per placca da trasporto e viti mini da 2,0 mm per la placca base

1 giro = 0,5 mm

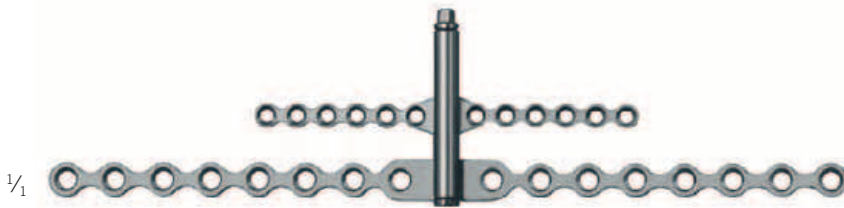

51-530-10 

TRACK 2.0

Distraktionslänge

Distraction length

Longitud de distracción

Longueur de distraction

Lunghezza di distrazione

10 mm

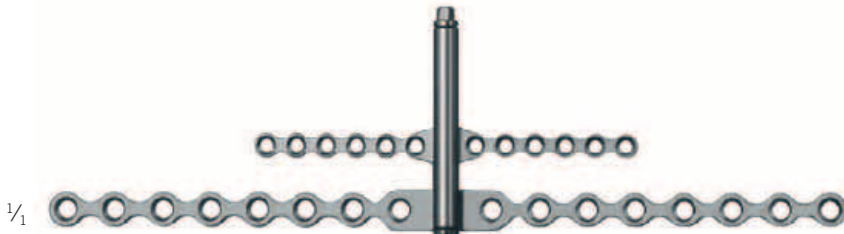

51-530-15 

TRACK 2.0

Distraktionslänge

Distraction length

Longitud de distracción

Longueur de distraction

Lunghezza di distrazione

15 mm

Bitte beachten:

Zum Schutz der Schweißzone empfehlen wir die Verwendung der Biegezangen 25-486-13 und 51-530-70. Siehe Seite 193.

Please note:

In order to protect the welding zone we recommend using the bending pliers 25-486-13 and 51-530-70. See page 193.

Rogamos que observe:

Para proteger la zona de soldadura, recomendamos la utilización de los alicates de moldeado 25-486-13 y los alicates de sujeción del distractor 51-530-70. Véase página 193.









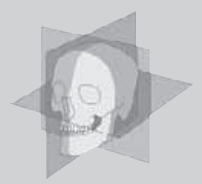



































Note :

afin d'assurer la protection de la zone de soudage, nous recommandons l'utilisation des pinces de pliage 25-486-13 et 51-530-70. Voir page 193.

Avvertenza:







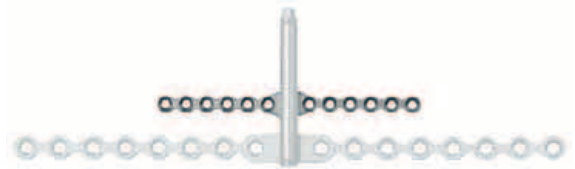

























al fine di proteggere l'area di saldatura consigliamo l'uso delle pinze piegaplacche 25-486-13 e 51-530-70. Vedi pagina 193.



Centre Drive®		Cross Drive	
selbsthaltend/self-retaining/autobloqueantes/ autobloquante/autoritensiva			
Mikro-Schrauben/Micro Screws/Tornillos Micro/ Vis Micro/Viti Micro			
			
1.5 x 4 mm	25-665-04  	25-675-04  	
1.5 x 5 mm	25-665-05  	25-675-05  	
1.5 x 6 mm	25-665-06  	25-675-06  	
1.5 x 7 mm	25-665-07  	25-675-07  	
Notfallschrauben/Emergency Screws/ Tornillos de emergencia/Vis d'urgence/Viti di emergenza			
			
1.8 x 5 mm	25-666-05  	25-676-05  	
1.8 x 7 mm	25-666-07  	25-676-07  	
Drill-Free-Schrauben/Drill-Free Screws/Tornillos Drill-Free/ Vis Drill-Free autotaraudeuses/Viti Drill-Free autoporanti			
			
1.5 x 4 mm	25-668-04  	25-678-04  	
1.5 x 5 mm	25-668-05  	25-678-05  	
1.5 x 6 mm	25-668-06  	25-678-06  	



1,5-mm-Schrauben für die Transportplatte
1.5 mm screws for transport plate
Tornillos de 1,5 mm para placas de transporte
Vis de 1,5 mm pour plaque de transport
Viti da 1,5 mm per placca da trasporto

Centre Drive®		Cross Drive	
selbsthaltend/self-retaining/autobloqueantes/ autobloquante/autoritensiva			
Mikro-Schrauben/Micro Screws/Tornillos Micro/ Vis Micro/Viti Micro			
			
2.0 x 5 mm	25-662-05  	25-672-05  	
2.0 x 6 mm	25-662-06  	25-672-06  	
2.0 x 7 mm	25-662-07  	25-672-07  	
Notfallschrauben/Emergency Screws/ Tornillos de emergencia/Vis d'urgence/Viti di emergenza			
			
2.3 x 7 mm	25-663-47  	25-673-47  	
Drill-Free-Schrauben/Drill-Free Screws/Tornillos Drill-Free/ Vis Drill-Free autotaraudeuses/Viti Drill-Free autoporanti			
			
2.0 x 5 mm	25-669-05  	25-679-05  	
2.0 x 6 mm	25-669-07  	25-679-07  	



2,0-mm-Schrauben für die Grundplatte
2.0 mm screws for base plate
Tornillos de 2,0 mm para la placa base
Vis de 2,0 mm pour plaque de base
Viti da 2,0 mm per placca base

TRACK 2,0-mm-Distraktoren

TRACK 2.0 mm Distractors
 Distractores TRACK 2,0 mm
 Distracteurs TRACK 2,0 mm
 Distrattori TRACK 2,0 mm

Vorbohrer für 1,5-mm-Mikro-Schrauben
 Twist drills for 1.5 mm micro screws
 Brocas para tornillos micro de 1,5 mm
 Mèches de préforage pour vis micro de 1,5 mm
 Frese per viti micro da 1,5 mm



Stryker-Ansatz, Stryker attachment, Sujeción tipo Stryker, Embout Stryker, Connessione Stryker

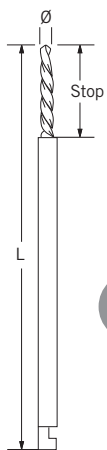

Ø x L (mm) Stop (mm)

1.1 x 50	–	25-452-00	St	5
1.1 x 50	–	25-452-00-91	St	1
1.1 x 50	5	25-452-05	St	5
1.1 x 50	5	25-452-05-91	St	1
1.1 x 50	7	25-452-07	St	5
1.1 x 50	7	25-452-07-91	St	1



Zylindrischer Ansatz, cylindrical attachment, Sujeción tipo cilíndrico, Embout cylindrique, Connessione cilindrica

Ø x L (mm) Stop (mm)

1.1 x 50	–	25-451-00	St	5
1.1 x 50	–	25-451-00-91	St	1
1.1 x 50	5	25-451-05	St	5
1.1 x 50	5	25-451-05-91	St	1
1.1 x 50	7	25-451-07	St	5
1.1 x 50	7	25-451-07-91	St	1

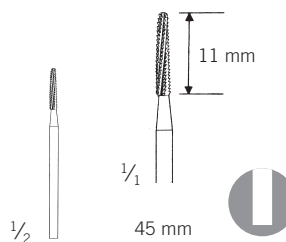

38-051-45

Fräse
 Milling cutter
 Broca para taladros previos
 Fraise
 Fresa

Vorbohrer für 2,0-mm-Mini-Schrauben
 Twist drills for 2.0 mm mini screws
 Brocas para tornillos mini de 2,0 mm
 Mèches de préforage pour vis mini de 2,0 mm
 Frese per viti mini da 2,0 mm



Stryker-Ansatz, Stryker attachment, Sujeción tipo Stryker, Embout Stryker, Connessione Stryker

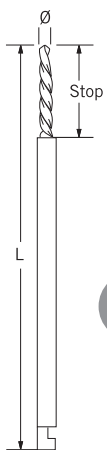

Ø x L (mm) Stop (mm)

1.5 x 50	5	25-449-05	St	5
1.5 x 50	5	25-449-05-91	St	1
1.5 x 50	7	25-449-07	St	5
1.5 x 50	7	25-449-07-91	St	1
1.5 x 50	20	25-449-16	St	5
1.5 x 50	20	25-449-16-91	St	1



Zylindrischer Ansatz, cylindrical attachment, Sujeción tipo cilíndrico, Embout cylindrique, Connessione cilindrica

Ø x L (mm) Stop (mm)

1.5 x 50	5	25-450-05	St	5
1.5 x 50	5	25-450-05-91	St	1
1.5 x 50	7	25-450-07	St	5
1.5 x 50	7	25-450-07-91	St	1
1.5 x 50	20	25-450-16	St	5
1.5 x 50	20	25-450-16-91	St	1

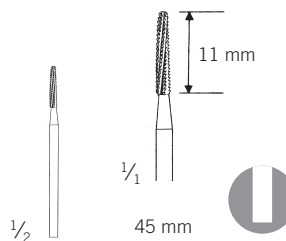

38-051-45

Fräse
 Milling cutter
 Broca para taladros previos
 Fraise
 Fresa

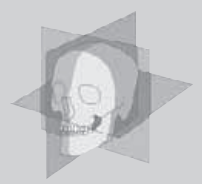

Schraubendreher und Funktionsteile
Screwdrivers and Blades
Destornilladores y terminales
Tournevis et lames
Cacciaviti e lame



Funktionsteile passend für
Blades suitable for
Mechas apropiadas para
Lames pour
Lame adatte per

25-431-98	⊖ 1.5 mm	x				
25-430-98	⊖ 1.5 mm		x			
25-432-98	⊕ 1.5 mm	x				
25-483-97	⊕ 1.5 mm		x			
25-434-98	⊕ 2.0 mm / 2.3 mm			x		
25-540-98	⊕ 2.0 mm / 2.3 mm			x	x	x
25-484-97	⊕ 2.0 mm / 2.3 mm		x			x
25-540-97	⊖ 2.0 mm / 2.3 mm			x	x	x

Starr, abgeflacht
Rigid, flattened
Rigido, aplinado
Rigide, aplati
Rigido, ribassato

Ratsche
Ratchet
Carraca
Cliquet
A cricco

Ratsche, abgeflacht
Ratchet, flattened
Carraca, aplanada
Cliquet, aplati
A cricco, ribassato

Festreh-Schraubendreher
Fixation Screwdrivers
Destornilladores de fijación
Tournevis de fixation
Cacciaviti per fissaggio

25-432-16	⊖ 1.5 mm
25-483-13	⊕ 1.5 mm
25-542-17	⊖ 2.0 mm / 2.3 mm
25-540-13	⊕ 2.0 mm / 2.3 mm



Bone-Graft-Schraubendreher
Bone Graft Screwdrivers
Destornilladores Bone Graft
Tournevis pour extraire la spongieuse Bone Graft
Cacciaviti Bone Graft

25-422-15	⊖ 1.5 mm
25-423-15	⊕ 1.5 mm
25-422-20	⊖ 2.0 mm
25-423-20	⊕ 2.0 mm



TRACK 2,0-mm-Distraktoren

TRACK 2.0 mm Distractors
 Distractores TRACK 2,0 mm
 Distracteurs TRACK 2,0 mm
 Distrattori TRACK 2,0 mm



51-500-90

Patientenschraubendreher, gerade,
 für TRACK 1,5 mm
 Patient screwdriver, straight,
 for TRACK 1.5 mm
 Destornillador del paciente, recto,
 para TRACK 1,5 mm
 Tournevis patient, droit,
 pour TRACK 1,5 mm
 Cacciavite per paziente, diritto,
 per TRACK da 1,5 mm



51-505-90

Patientenschraubendreher,
 abgewinkelt, für TRACK 1,5 mm
 Patient screwdriver, angled,
 for TRACK 1.5 mm
 Destornillador del paciente,
 articulado, para TRACK 1,5 mm
 Tournevis patient, courbe,
 pour TRACK 1,5 mm
 Cacciavite per paziente, ricurvo,
 per TRACK da 1,5 mm



51-520-95

Patientenschraubendreher, mikro,
 für TRACK 1,5 mm
 Patient screwdriver, micro,
 for TRACK 1.5 mm
 Destornillador del paciente, micro,
 para TRACK 1,5 mm
 Tournevis patient, micro,
 pour TRACK 1,5 mm
 Cacciavite per paziente, micro,
 per TRACK da 1,5 mm



Lindorf
 25-435-15

18 cm / 7 1/8"
 Platten-Halteinstrument
 Plate-holding instrument
 Instrumento para sujetar placas
 Instrument à saisir les plaques
 Strumento di presa per placche



51-525-80

15,5 cm / 6 1/8"
 Platten-Fasspinzette,
 gebogen
 Plate-holding forceps,
 curved
 Pinza para sujetar
 placas, curvada
 Pince à saisir les
 plaques, courbe
 Pinza di presa per
 placche, curva

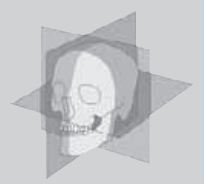

TC GOLD

TC GOLD

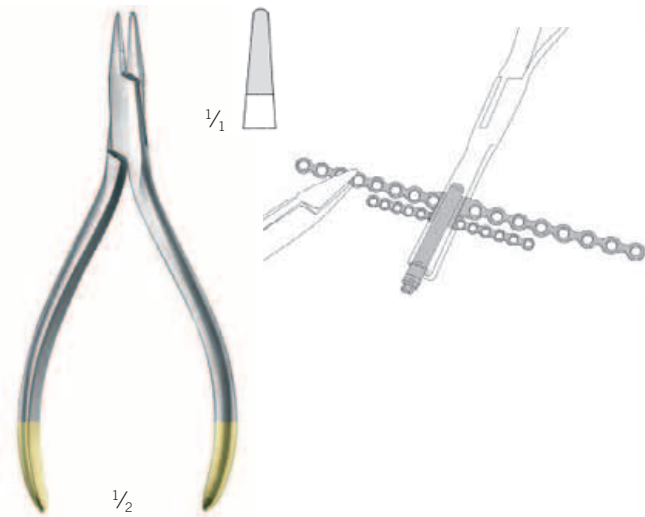

25-486-13
13 cm / 5 1/8"
Modellierzange
Modeling pliers
Alicates de moldeado
Pince à modeler
Pinza modellante



51-530-70
13 cm / 5 1/8"
Distraktor-Haltezange für TRACK 2.0 mm
Distractor holding plier for TRACK 2.0 mm
Alicates de sujeción del distractor para TRACK 2,0 mm
Pince à saisir les distracteurs pour TRACK 2,0 mm
Pinza per tenuta distrattore per TRACK da 2,0 mm



25-420-16
16 cm / 6 2/8"
Plattenschneider
Plate cutter
Alicates de corte para placas
Pince à couper les plaques
Taglia placche

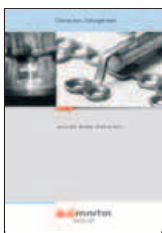

Weitere Informationen finden Sie in unserem Katalog "Alveolar Ridge Distraction"

For further information, please refer to our "Alveolar Ridge Distraction"

Podrá encontrar informaciones adicionales en nuestro catálogo "Alveolar Ridge Distraction"

Vous trouverez de plus amples informations dans notre catalogue «Alveolar Ridge Distraction»

Ulteriori informazioni sono fornite nel nostro catalogo "Alveolar Ridge Distraction"

LEVEL ONE FIXATION



Die Lagerungsmodule

Eine Vielzahl vorkonfigurierter Lagerungsmodule für spezifische Anwendungen oder ganz individuell zusammengestellte Sets sind möglich. Die klare Farbkodierung der Module erleichtert den Umgang und die Zuordnung.

The storage modules

A great number of preconfigured storage modules are available for specific applications, but the user may also obtain fully customized sets. The clear color-coding of the modules ensures easy handling and assignment.

Los módulos de almacenaje

Se puede preconfigurar numerosos módulos de almacenaje para aplicaciones específicas o componer sets de forma totalmente individual. La codificación de color inequívoca de los módulos facilita la manipulación y la asignación.

Les modules de rangement

Une multitude de modules de rangement préconfigurés pour des applications spécifiques ou des sets composés individuellement sont possibles. Le codage clair par couleurs des modules facilite la manipulation et l'affectation.

I moduli di supporto

È disponibile una gran varietà di moduli di supporto preconfigurati per applicazioni specifiche, ma l'utente può anche avere dei set composti in modo completamente personalizzato. La chiara codifica a colori dei moduli assicura una facile gestione e assegnazione degli stessi.

Flexible Grundmodule

Ein Baustein des LEVEL-ONE-Systems sind die flexiblen Grundmodule mit den vielfältigen Möglichkeiten der Implantat- und Instrumentenlagerung.

Versatile basic modules

The versatile basic modules that offer the user a multitude of implant and instrument storage options represent just one component of the LEVEL ONE system.

Módulos básicos flexibles

Los versátiles módulos básicos, que le ofrecen al usuario numerosas posibilidades de almacenaje de implantes e instrumentos sólo son un componente del sistema LEVEL ONE.

Modules de base flexibles

Les modules de base flexibles avec les possibilités multiples de rangement des implants et des instruments sont un élément du système LEVEL ONE.

Moduli di base versatili

Una componente del sistema LEVEL ONE è rappresentata dai moduli di base versatili con molteplici possibilità per il supporto di impianti e strumenti.



Die Schraubenverpackungen

Farbkodiert entsprechend dem Schraubendurchmesser, mit je 5 Schrauben. Die Clipmagazine lassen sich direkt in das Lagerungssystem einsetzen. Das zeit- und nervenraubende Umstecken einzelner Schrauben entfällt. Im patentierten, modularen LEVEL-ONE-System enthält jedes Clipmagazin Informationen zu Schraubenlänge und Durchmesser sowie Artikel- und Chargennummer zur Gewährleistung lückenloser Rückverfolgbarkeit.

The screw packages

Color-coded by screw diameter, with 5 screws per pack. The clip magazines can be directly inserted into the storage system. No more time-consuming and stressful sorting out of individual screws. In the patented, modular LEVEL ONE system, each clip magazine provides information on screw length and diameter as well as item and lot numbers. This guarantees “no-gap” traceability.

Los embalajes para tornillos

Codificados por colores según el diámetro del tornillo y con cinco tornillos por unidad. Los depósitos sujetatornillos pueden colocarse directamente en el sistema de almacenaje. Ya no se requiere la laboriosa y fastidiosa clasificación de tornillos individuales. En el sistema modular patentado LEVEL ONE, cada depósito sujetatornillos contiene

informaciones sobre la longitud del tornillo y su diámetro, así como el número de referencia y de lote para poder garantizar una trazabilidad total.

Les emballages de vis

Codés par couleurs en fonction du diamètre des vis, contenant 5 vis chacun. Les chargeurs à clip peuvent être insérés directement dans le système de rangement. Plus de perte de temps et d'énerverment pour trier les vis une par une. Dans le système LEVEL ONE modulaire breveté, chaque rangement à clip contient des informations sur la longueur et le diamètre des vis ainsi que les numéros d'articles et de charges, afin de garantir une traçabilité sans lacunes.

Confezioni delle viti

Sono codificate a colore in funzione del diametro della vite, con 5 viti ciascuna. I contenitori-clip per viti si possono impiegare direttamente dal sistema di supporto. Non è più necessaria la selezione delle singole viti che richiedeva tempo e generava stress. Nel sistema brevettato modulare LEVEL ONE ogni contenitori-clip per viti contiene informazioni sulla lunghezza delle viti e sul diametro così come il numero di articolo e di lotto per garantire una rintracciabilità capillare.

Bone Graft Kit

Bone Graft Kit

Kit Bone Graft

Kit pour greffe osseuse

Kit per innesti ossei

Für die optimale Fixation bei allen rekonstruktiven, präprothetischen Eingriffen

- Schraubengrößen: 1,0 – 1,5 – 2,0 mm, low profile
- Alle Größen sind als selbstschneidende Schrauben verfügbar
- Ausgewählte Schraubengrößen sind als Drill-Free-Ausführung erhältlich
- Micro-Mesh in drei praktischen Abmessungen
- Höchste Bio-Kompatibilität aller Komponenten gewährleistet

The right fixation for all of your reconstructive, preprosthetic procedures

- Screw sizes: 1.0 – 1.5 – 2.0 mm, low profile
- All sizes available as self-tapping screws
- Selected sizes available as Drill-Free screws
- Micro mesh in three convenient sizes
- High bio-compatibility

Para la fijación óptima en todas las intervenciones reconstructivas preprotésicas

- Tamaños de tornillo: 1,0 – 1,5 – 2,0 mm, perfil bajo
- Todos los tamaños están disponibles como tornillos autoroscantes
- Determinados tamaños de tornillo están disponibles en diseño Drill-Free
- Micro malla en tres prácticas dimensiones
- Garantía de máxima biocompatibilidad de todos los componentes



50-700-00

Bone Graft Kit, komplett, ohne Instrumentarium
Bone Graft Kit, complete, without instruments
Kit Bone Graft, completo, sin instrumental
Kit pour greffe osseuse, complet, sans instruments
Kit per innesti ossei completo, senza strumenti

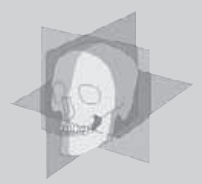

Pour la fixation optimale dans toutes vos interventions reconstructrices et préprothétiques

- Tailles de vis: 1,0 – 1,5 – 2,0 mm, profil bas
- Toutes les tailles sont disponibles sous forme de vis autotaraudeuses
- Des tailles de vis sélectionnées sont disponibles dans le modèle Drill-Free
- Mesh Micro dans trois dimensions pratiques
- Garantie de très grande biocompatibilité de tous les composants

Per il fissaggio ottimale in tutti gli interventi ricostruttivi e preprotesi

- Misure delle viti: 1,0 – 1,5 – 2,0 mm, basso profilo
- Tutte le misure sono disponibili come viti ad autoritentiva
- Le misure delle viti selezionate sono disponibili come versione Drill-Free autopercorante
- Mesh Micro in tre pratiche misure
- Altissima biocompatibilità di tutti i componenti garantita

50-700-00	Bone Graft Kit, komplett	Bone Graft Kit, complete	Kit Bone Graft, completo	Kit pour greffe osseuse, complet	Kit innesti ossei, completo
	bestehend aus:	consisting of:	formato por:	composé de:	consistente in:
55-962-07	Insertmodul, grau	Insert module, grey	Módulo insertable, gris	Module d'inserts, gris	Modulo di inserto, grigio
55-964-28	Insert Bone Graft Kit	Insert Bone Graft Kit	Bandeja para Kit Bone Graft	Insert pour kit pour greffe osseuse	Inserto per Kit innesti ossei
55-963-28	Deckel Bone Graft Kit	Lid for Bone Graft Kit	Tapa para el Kit Bone Graft	Couvercle pour kit pour greffe osseuse	Coperchio per Kit innesti ossei

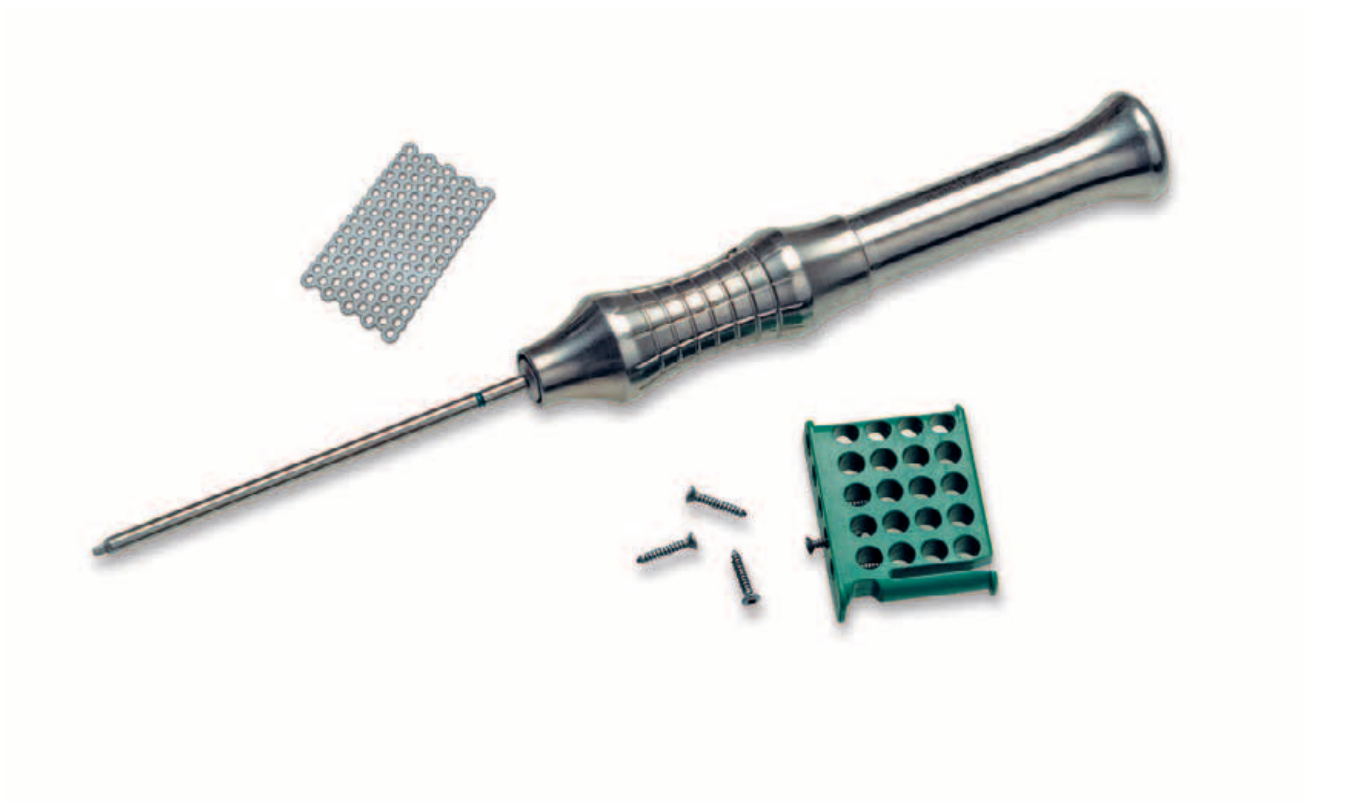

Bone Graft Kit

Bone Graft Kit

Kit Bone Graft

Kit pour greffe osseuse

Kit per innesti ossei

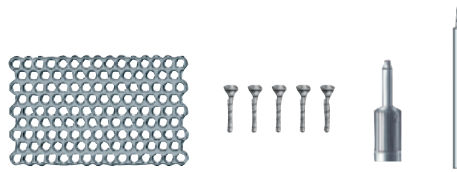

Mesh- bzw. Membranfixierung
Mesh/Membrane Fixation
Fijación de Mesh/membranas
Fixation Mesh/membrane
Fissaggio di Mesh/membrana

	Kategorie	Category	Categoría	Catégorie	Categoria	
25-040-40	1	Mikro-Mesh 0,2 mm, 25 x 15 mm	Micro Mesh 0.2 mm, 25 x 15 mm	Micro mesh de 0,2 mm, 25 x 15 mm	Mesh micro 0,2 mm 25 x 15 mm	Mesh micro da 0,2 mm, 25 x 15 mm
25-660-03	1	Titan-Mikro-Centre-Drive®-Schraube 1,0 x 3,0 mm	Titanium Micro Centre Drive® screw 1.0 x 3.0 mm	Tornillo Centre Drive® micro de titanio, 1,0 x 3,0 mm	Vis micro Center Drive® en titane, 1,0 x 3,0 mm	Vite Centre Drive® micro al titanio da 1,0 x 3,0 mm
25-455-05-91	1*	Vorbohrer 0,8 x 50 mm, 5-mm-Anschlag, zylindrisch	Twist drill 0.8 x 50 mm, 5 mm stop, cylindrical	Broca para taladros previos, 0,8 x 50 mm, 5 mm tope, cilíndrica	Mèche de préforage 0,8 x 50 mm, butée 5 mm, cylindrique	Foratore da 0,8 x 50 mm, arresto 5 mm, cilindrico
25-422-10	1	Centre-Drive®-Bone-Graft-Schraubendreher	Bone Graft screwdriver Centre Drive®	Mechas para destornillador Centre Drive® Bone Graft	Tournevis Centre Drive® pour greffe osseuse	Cacciavite Centre Drive® per Bone Graft (innesti ossei)
		* 1 Pck. à 5 Stück	* 1 Pck = 5 pieces	* 1 caja = 5 unidades	* 1 paquet = 5 unités	* 1 confezione da 5 pezzi

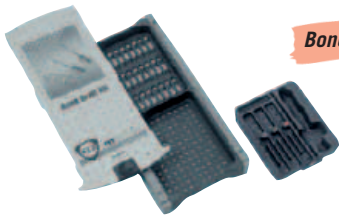

Bone Graft Kit

50-700-00	1	Bone Graft Kit (ohne Instrumente)	Bone Graft Kit (w/o instruments)	Bone Graft Kit (sin instrumentos)	Kit pour greffe osseuse (sans instruments)	Kit per Bone Graft (innesti ossei) (senza strumenti)
-----------	---	-----------------------------------	----------------------------------	-----------------------------------	--	--



Starter Kit

55-969-70	1	Bone Graft Starter Kit (ohne Instrumente)	Bone Graft Starter Kit (w/o instruments)	Bone Graft Starter Kit (sin instrumentos)	Kit de base pour greffe osseuse (sans instruments)	Starter Kit per Bone Graft (innesti ossei) (senza strumenti)
-----------	---	---	--	---	--	--

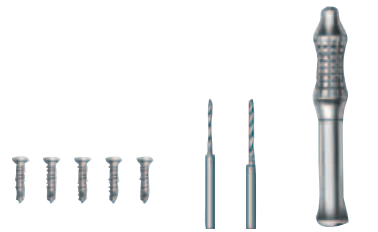
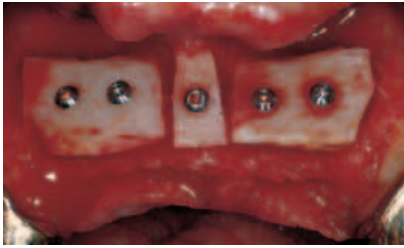
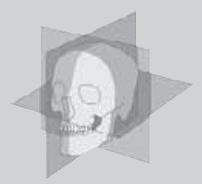

Bestellvorschlag für Knochenblockfixierung
Order recommendation for Bone Block Fixation
Recomendación de pedido para la fijación de bloques óseos
Recommandation de commande pour fixation du bloc osseux
Proposta di ordinazione per fissaggio di blocco osseo

	Kategorie	Category	Categoría	Catégorie	Categoria	
25-675-09	1*	Titan-Cross-Drive-Schraube, 1,5 x 9 mm	Titanium Cross Drive screw, 1,5 x 9 mm	Tornillo Cross Drive de titanio, 1,5 x 9 mm	Vis Cross Drive en titane, 1,5 x 9 mm	Vite Cross Drive al titanio da 1,5 x 9 mm
25-675-11	1*	Titan-Cross-Drive-Schraube, 1,5 x 11 mm	Titanium Cross Drive screw, 1,5 x 11 mm	Tornillo Cross Drive de titanio, 1,5 x 11 mm	Vis Cross Drive en titane, 1,5 x 11 mm	Vite Cross Drive al titanio da 1,5 x 11 mm
25-451-15-91	1	Vorbohrer 1,1 x 50 mm, 15 mm Anschlag, zylindrisch	Twist drill 1.1 x 50 mm, 15 mm stop, cylindrical	Broca para taladros previos, 1,1 x 50 mm, 15 mm tope, cilíndrica	Mèche de préforage 1,1 x 50 mm, butée 15 mm, cylindrique	Foratore da 1,1 x 50 mm, arresto 15 mm, cilindrico
25-450-16-91	1	Vorbohrer 1,5 x 50 mm, 20 mm Anschlag, zylindrisch	Twist drill 1.5 x 50 mm, 20 mm stop, cylindrical	Broca para taladros previos, 1,5 x 50 mm, 20 mm tope, cilíndrica	Mèche de préforage 1,5 x 50 mm, butée 20 mm, cylindrique	Foratore da 1,5 x 50 mm, arresto 20 mm, cilindrico
25-402-99	1	Handgriff allein	Screwdriver handle, only	Mango individual	Poignée pour tournevis seulement	Impugnatura singola
25-483-97	1	Funktionsteil Cross Drive 1,5 mm	Blade Cross Drive 1.5 mm	Mecha Cross Drive, 1,5 mm	Lame Cross Drive 1,5 mm	Pezzo funzionale Cross Drive da 1,5 mm
		* 1 Pck. à 5 Stück	* 1 Pck = 5 pieces	* 1 caja = 5 unidades	* 1 paquet = 5 unités	* 1 confezione da 5 pezzi

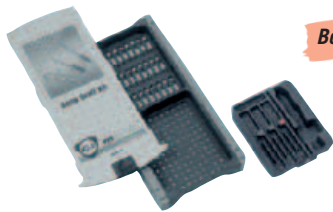

Bone Graft Kit

55-700-00	1	Bone Graft Kit (ohne Instrumente)	Bone Graft Kit (w/o instruments)	Bone Graft Kit (sin instrumentos)	Kit pour greffe osseuse (sans instruments)	Kit per Bone Graft (innesti ossei) (senza strumenti)
-----------	---	-----------------------------------	----------------------------------	-----------------------------------	--	--

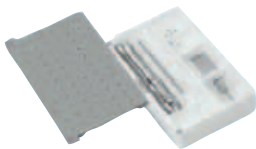

Starter Kit

55-969-70	1	Bone Graft Starter Kit (ohne Instrumente)	Bone Graft Starter Kit (w/o instruments)	Bone Graft Starter Kit (sin instrumentos)	Kit de base pour greffe osseuse (sans instruments)	Starter Kit per Bone Graft (innesti ossei) (senza strumenti)
-----------	---	---	--	---	--	--

















Bone Graft Kit

Bone Graft Kit

Kit Bone Graft

Kit pour greffe osseuse

Kit per innesti ossei

Centre Drive®			Cross Drive		
selbsthaltend / self-retaining / autobloqueantes / autobloquante / autoritensiva					
Mikro-Schrauben/Micro Screws/Tornillos Micro/Vis Micro/Viti Micro					
					
1.0 x 2 mm	25-660-02	Ti S		25-670-02	Ti S
1.0 x 3 mm	25-660-03	Ti S		25-670-03	Ti S
1.0 x 4 mm	25-660-04	Ti S		25-670-04	Ti S
1.0 x 5 mm	25-660-05	Ti S		25-670-05	Ti S
1.0 x 6 mm	25-660-06	Ti S		25-670-06	Ti S
1.0 x 7 mm	25-660-07	Ti S		25-670-07	Ti S
1.0 x 9 mm	25-660-09	Ti S		25-670-09	Ti S
1.0 x 11 mm	25-660-11	Ti S		25-670-11	Ti S
1.0 x 13 mm	25-660-13	Ti S		25-670-13	Ti S
Notfallschrauben/Emergency Screws/Tornillos de emergencia/Vis d'urgence/Viti di emergenza					
					
1.2 x 3 mm	25-661-03	Ti S		25-671-03	Ti S
1.2 x 5 mm	25-661-05	Ti S		25-671-05	Ti S
Mikro-Schrauben/Micro Screws/Tornillos Micro/Vis Micro/Viti Micro					
					
1.2 x 5 mm	25-601-05	Ti S			
1.2 x 7 mm	25-601-07	Ti S			
1.2 x 9 mm	25-601-09	Ti S			
1.2 x 11 mm	25-601-11	Ti S			
1.2 x 13 mm	25-601-13	Ti S			
Mikro-Schrauben/Micro Screws/Tornillos Micro/Vis Micro/Viti Micro					
		STERILE R			STERILE R
1.5 x 3.5 mm	25-665-03	Ti S	25-665-03 -72 Ti 2 -75 Ti S	25-675-03	Ti S
1.5 x 4 mm	25-665-04	Ti S	25-665-04 -72 Ti 2 -75 Ti S	25-675-04	Ti S
1.5 x 5 mm	25-665-05	Ti S	25-665-05 -72 Ti 2 -75 Ti S	25-675-05	Ti S
1.5 x 6 mm	25-665-06	Ti S	25-665-06 -72 Ti 2 -75 Ti S	25-675-06	Ti S
1.5 x 7 mm	25-665-07	Ti S	25-665-07 -72 Ti 2 -75 Ti S	25-675-07	Ti S
1.5 x 8 mm	25-665-08	Ti S	25-665-08 -72 Ti 2 -75 Ti S	25-675-08	Ti S
1.5 x 9 mm	25-665-09	Ti S	25-665-09 -72 Ti 2 -75 Ti S	25-675-09	Ti S
1.5 x 11 mm	25-665-11	Ti S	25-665-11 -72 Ti 2 -75 Ti S	25-675-11	Ti S
1.5 x 13 mm	25-665-13	Ti S	25-665-13 -72 Ti 2 -75 Ti S	25-675-13	Ti S
1.5 x 15 mm	25-665-15	Ti S	25-665-15 -72 Ti 2 -75 Ti S	25-675-15	Ti S
Notfallschrauben/Emergency Screws/Tornillos de emergencia/Vis d'urgence/Viti di emergenza					
					
1.8 x 3.5 mm	25-666-03	Ti S	25-666-03 -72 Ti 2 -75 Ti S	25-676-03	Ti S
1.8 x 5 mm	25-666-05	Ti S	25-666-05 -72 Ti 2 -75 Ti S	25-676-05	Ti S
1.8 x 7 mm	25-666-07	Ti S	25-666-07 -72 Ti 2 -75 Ti S	25-676-07	Ti S
Drill-Free-Schrauben/Drill-Free Screws/Tornillos Drill-Free/Vis Drill-Free autotaraudeuses/Viti Drill-Free autopercoranti					
					
1.5 x 4 mm	25-668-04	Ti S	25-668-04 -72 Ti 2 -75 Ti S	25-678-04	Ti S
1.5 x 5 mm	25-668-05	Ti S	25-668-05 -72 Ti 2 -75 Ti S	25-678-05	Ti S
1.5 x 6 mm	25-668-06	Ti S	25-668-06 -72 Ti 2 -75 Ti S	25-678-06	Ti S
1.5 x 7 mm	25-668-07	Ti S	25-668-07 -72 Ti 2 -75 Ti S	25-678-07	Ti S

- Lieferung in autoklavierbaren Clipmagazinen
- Auf Wunsch auch steril verpackt
- Durchgängige Farbcodierung – einfache Orientierung
- Komplette Patientendokumentation und Wiederverfögarkeit

- Supplied in autoclavable clip magazines
- Sterile packaging alternatively available on request
- Systematic color coding for easy orientation
- Full patient documentation with 100% traceability

- Suministro en depósitos sujetatornillos esterilizables en autoclave
- A petición también se suministran en embalaje estéril
- Codificación cromática completa – orientación sencilla
- Documentación completa del paciente y trazabilidad al 100 %

- Livraison dans des chargeurs à clip autoclavables
- Emballage stérile également disponible sur demande
- Codage par couleurs conséquent – orientation simple
- Documentation complète du patient et traçabilité

- Consegna in clip magazine autoclavabili
- Su richiesta anche in imballaggio sterile
- Codice cromatico su tutti gli strumenti – per semplificare l'orientamento
- Completa documentazione paziente e rintracciabilità

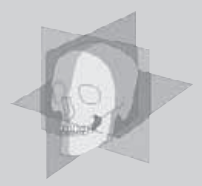

























































































































































Centre Drive®

































Cross Drive

selbsthaltend/self-retaining/autobloqueantes/autobloquante/autoritativa

Mini-Schrauben/Mini Screws/Tornillos Mini/Vis Mini/Viti Mini





















		STERILE	R		STERILE	R
						
2.0 x 4 mm	25-662-04  	25-662-04 -72   -75  		25-672-04  	25-672-04 -72   -75  	
2.0 x 5 mm	25-662-05  	25-662-05 -72   -75  		25-672-05  	25-672-05 -72   -75  	
2.0 x 6 mm				25-672-06  		
2.0 x 7 mm	25-662-07  	25-662-07 -72   -75  		25-672-07  	25-672-07 -72   -75  	
2.0 x 9 mm	25-662-09  	25-662-09 -72   -75  		25-672-09  	25-672-09 -72   -75  	
2.0 x 11 mm	25-662-11  	25-662-11 -72   -75  		25-672-11  	25-672-11 -72   -75  	
2.0 x 13 mm	25-662-13  	25-662-13 -72   -75  		25-672-13  	25-672-13 -72   -75  	
2.0 x 15 mm	25-662-15  	25-662-15 -72   -75  		25-672-15  	25-672-15 -72   -75  	
2.0 x 17 mm	25-662-17  	25-662-17 -72   -75  		25-672-17  	25-672-17 -72   -75  	
2.0 x 19 mm	25-662-19  	25-662-19 -72   -75  		25-672-19  	25-672-19 -72   -75  	
						
2.0 x 4 mm	25-662-34  			25-672-34  		
2.0 x 5 mm	25-662-35  			25-672-35  		
2.0 x 6 mm				25-672-36  		
2.0 x 7 mm	25-662-37  			25-672-37  		
2.0 x 9 mm	25-662-39  			25-672-39  		
2.0 x 11 mm	25-662-41  			25-672-41  		
2.0 x 13 mm	25-662-43  			25-672-43  		
2.0 x 15 mm	25-662-45  			25-672-45  		
2.0 x 17 mm	25-662-47  			25-672-47  		
2.0 x 19 mm	25-662-49  			25-672-49  		

Notfallschrauben/Emergency Screws/Tornillos de emergencia/Vis d'urgence/Viti di emergenza

						
2.3 x 5 mm	25-663-45  			25-673-45  		
2.3 x 7 mm	25-663-47  	25-663-47 -75  		25-673-47  	25-673-47 -75  	
2.3 x 9 mm	25-663-49  	25-663-49 -75  		25-673-49  	25-673-49 -75  	
						
2.3 x 7 mm	25-663-37  			25-673-37  		
2.3 x 9 mm	25-663-39  			25-673-39  		

Drill-Free-Schrauben/Drill-Free Screws/Tornillos Drill-Free/Vis Drill-Free autotaraudeuses/Viti Drill-Free autopercoranti

selbsthaltend/self-retaining/autobloqueantes/autobloquante/autoritativa

						
2.0 x 5 mm	25-669-05  	25-669-05 -72   -75  		25-679-05  	25-679-05 -72   -75  	
2.0 x 7 mm	25-669-07  	25-669-07 -72   -75  		25-679-07  	25-679-07 -72   -75  	

-  Stahlschrauben nur in Verbindung mit Champy-Stahl-Implantaten
To be used only in connection with Champy stainless steel implants
Tornillos de acero sólo en combinación con implantes Champy de acero
A utiliser uniquement en liaison avec des implants Champy en acier inoxydable
Utilizzare le viti in acciaio solo con placche in acciaio Champy

Drill-Free-Schrauben

sind selbstbohrende Schrauben, die bei normaler Knochendichte eine optimale Schneidfunktion aufweisen. Einfach aufstecken und eindrehen.

- Kein Vorboren und keine nekrotische Knochenreaktion
- Keine Gewebe- und Nervenschädigung möglich
- Eindeutige Zuordnung durch goldene Eloxierung

Drill-Free screws

are self-tapping screws offering optimal cutting capability in bone of normal density. Just pick up and screw in!

- No pre-drilling, no necrotic bone responses
- Tissue and nerve damage prevented
- Mix-up prevented due to golden anodic coating

Los tornillos Drill-Free

son tornillos autotaladrantes, que presentan una función de corte óptima en relación con densidades óseas normales. Sólo deberá colocarlos en la mecha del destornillador y atornillarlos.

- No requieren taladro previo y no ocasionan reacciones óseas necróticas
- No son posibles lesiones en tejidos y nervios
- Asignación inequívoca gracias al anodizado dorado

Les vis Drill-Free

Les vis Drill Free sont des vis autotaraudeuses qui permettent une coupe optimale en cas de densité osseuse normale. Il suffit de les placer sur la lame du tournevis et de les enfoncer en tournant.

- Pas de préforage et pas de réaction nécrotique de l'os
- Lésions des tissus et des nerfs exclues
- Affectation claire grâce à une anodisation dorée

Le viti Drill-Free

sono viti autopercoranti caratterizzate da una funzione di taglio ottimale in relazione ad una densità ossea regolare. È sufficiente raccogliere queste viti ad autotenuta con la punta del cacciavite e avvitare.

- Non è necessario preperforare e non viene causata una reazione di necrosi ossea
- Nessun rischio di danneggiamento del tessuto e dei nervi
- Chiara classificazione grazie all'anodizzazione dorata

Bone Graft Kit

Bone Graft Kit

Kit Bone Graft

Kit pour greffe osseuse

Kit per innesti ossei



Farbkodierte Clipmagazine vereinfachen das Schraubehandling in genialer Weise. Die handlichen Magazine rasten leicht in jeder gewünschten Position im Schraubenmodul ein. Der passende Längenmess-einsatz ist beliebig positionierbar. Die einzelnen Magazine sind mit Schraubenlänge und Artikelnummer beschriftet. Die Farbkodierung ist gerade beim Einsatz verschiedener Schraubendurchmesser besonders übersichtlich.

Color-coded clip magazines are a brilliant screw-handling solution. The handy magazines easily snap in place in the screw module at the desired position. The corresponding length-measuring clip can be positioned as desired. The various magazines are labeled with the screw length and the reference number. The color-coding technique is particularly helpful when using different screw diameters.

Los depósitos sujetatornillos con codificación cromática simplifican de forma genial la manipulación de los tornillos. Los cómodos depósitos encajan con facilidad en cualquier posición deseada dentro del módulo para tornillos. El inserto adecuado para mediciones longitudinales puede colocarse en cualquier posición. Los depósitos sujetatornillos individuales están rotulados con la longitud de tornillo y el número de referencia. Sobre todo al utilizar diferentes diámetros de tornillo resulta especialmente inequívoca la codificación cromática.

Des chargeurs à clip codés par couleurs simplifient la manipulation des vis de manière géniale. Les chargeurs maniables s'enclenchent facilement dans le module pour vis dans chaque position souhaitée. La jauge de longueur correspondante peut être positionnée à volonté. La longueur de la vis et la référence sont inscrites sur les différents chargeurs. Le codage par couleurs est particulièrement utile lorsque différents diamètres de vis sont utilisés.

I clip magazine con codici cromatici semplificano il trattamento delle viti in modo geniale. I contenitori maneggevoli scattano facilmente nella posizione desiderata nel modulo di viti. L'inserto adatto per la misurazione della lunghezza è posizionabile a piacimento. I singoli contenitori sono muniti di dicitura indicante la lunghezza delle viti ed il codice articolo. La codificazione cromatica è particolarmente chiara e trasparente nel caso di impiego di viti di diametro diverso.



- 25-040-30 = 100 x 100 mm
- 25-040-35 = 30 x 30 mm
- 25-040-40 = 25 x 15 mm
- Micro Mesh (0.2 mm)
- Micro Malla (0,2 mm)



1/2

- 25-453-05
- 25-453-05-91
- Ø 0.7 x 50 mm



- 25-451-15
- 25-451-15-91
- Ø 1.1 x 50 mm



- 25-450-16
- 25-450-16-91
- Ø 1.5 x 50 mm



1/2

- Bone-Graft-Schraubendreher
- Bone Graft screwdrivers
- Destornilladores Bone Graft
- Tournevis pour greffe osseuse
- Cacciavite per innesti ossei

- | | | | |
|--------|-----|-----------|--|
| 1.0 mm | ● ⊕ | 25-422-10 | |
| 1.5 mm | ● ⊕ | 25-422-15 | |
| 2.0 mm | ● ⊕ | 25-422-20 | |

Centre Drive®

- | | | | |
|--------|-----|-----------|--|
| 1.0 mm | ● ⊕ | 25-423-10 | |
| 1.5 mm | ● ⊕ | 25-423-15 | |
| 2.0 mm | ● ⊕ | 25-423-20 | |

Cross Drive



1/2

- 25-402-99
- Schraubendreher-Handgriff
- Screwdriver handle
- Mango para destornillador
- Poignée pour tournevis
- Manico cacciavite



1/2

- | | | | |
|--------|---|-----------|--|
| 1.0 mm | ● | 25-428-98 | |
| 1.5 mm | ● | 25-430-98 | |
| 2.0 mm | ● | 25-434-98 | |

- Centre-Drive®-Ansätze
- Centre Drive® blades
- Terminales Centre Drive®
- Embouts Centre Drive®
- Lame Centre Drive®



1/2

- | | | | |
|--------|---|-----------|--|
| 1.0 mm | ● | 25-429-98 | |
| 1.5 mm | ● | 25-483-97 | |
| 2.0 mm | ● | 25-484-97 | |

- Cross-Drive-Ansätze
- Cross Drive blades
- Terminales Cross Drive
- Embouts Cross Drive
- Lame Cross Drive

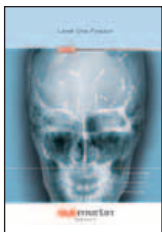

Weitere Informationen finden Sie in unserem Katalog "LEVEL ONE"

For further information, please refer to our "LEVEL ONE" catalog

Podrá encontrar informaciones adicionales en nuestro catálogo "LEVEL ONE"

Vous trouverez de plus amples informations dans notre catalogue «LEVEL ONE»

Ulteriori informazioni sono fornite nel nostro catalogo "LEVEL ONE"

Sonic Weld Rx[®] –

Die Revolution der Osteosynthese

KLS Martin hat mit SonicWeld Rx[®] ein revolutionäres System für rekonstruktive kraneofaziale Eingriffe und für Mittelgesichts-traumata entwickelt. Modernste Ultraschalltechnik, kombiniert mit resorbierbaren Implantaten, machen das Leben für Patient und Chirurg deutlich einfacher. Dank des völlig neuen Verschweißungsprozesses verankert sich das resorbierbare Material tief in der Knochenstruktur und erzeugt eine bislang ungekannte Primärstabilität. In der präprothetischen Augmentation eignet sich das System für resorbierbare Membranfixierungen (Guided Bone Regeneration), Auflagerungen (Onlay Grafts) und Schalungen (Split Grafts).



Osteosynthesis



GB

Sonic Weld Rx® – The revolution in osteosynthesis

With SonicWeld Rx®, KLS Martin offers a revolutionary system for reconstructive craniofacial interventions and midface trauma. Highly advanced ultrasound technology combined with resorbable implants makes life a great deal easier for patients and surgeons alike. Thanks to the completely novel welding technique, the bioabsorbable material penetrates deeply into the bone structure to provide a level of primary stability never seen before. In preprosthetic augmentation, this system can be used for resorbable membrane fixation (Guided Bone Regeneration), appositions (onlay grafts) procedures based on the innovative shell technique (split grafts).

ES

Sonic Weld Rx® – La revolución de la osteosíntesis

Con SonicWeld Rx®, KLS Martin ha desarrollado un sistema revolucionario para intervenciones de reconstrucción craneofacial y para traumatismos de la parte media de la cara. La más avanzada tecnología de ultrasonidos, combinada con implantes reabsorbibles, simplifica en gran medida la vida para el paciente y para el cirujano. Gracias al proceso totalmente novedoso de soldadura, el material bioabsorbible penetra en profundidad dentro de la estructura ósea, proporcionando un nivel de estabilidad primaria desconocida hasta el momento. En el aumento preprotésico, este sistema es apropiado para ser utilizado en fijaciones de membranas reabsorbibles (Guided Bone Regeneration - regeneración ósea guiada), aposiciones (onlay grafts) y la técnica de valva (split grafts).

F

Sonic Weld Rx® – La révolution de l'ostéosynthèse

Avec SonicWeld Rx® KLS Martin a mis au point un système révolutionnaire pour les interventions crânio-faciales reconstructrices et pour les traumatismes de l'étage moyen de la face. Une technique d'échographie très moderne associée à des implants résorbables simplifie notablement la vie du patient et du chirurgien. Grâce au processus de soudage entièrement nouveau, le matériau résorbable s'ancre profondément dans la structure osseuse, générant une stabilité primaire inconnue jusqu'ici. Lors des augmentations pré-prothétiques, le système est adapté à des fixations de membranes résorbables (Guided Bone Regeneration), à des greffes d'apposition (Onlay Grafts) et à des coquilles (Split Grafts).

I

Sonic Weld Rx® – La rivoluzione dell'osteosintesi

KLS Martin ha sviluppato con SonicWeld Rx® un sistema rivoluzionario per interventi di chirurgia craniofaciale ricostruttiva e per traumi della parte centrale del viso. La più moderna tecnica ad ultrasuoni, combinata con impianti riassorbibili, semplificano notevolmente la vita del paziente e del chirurgo. Grazie al processo di saldatura del tutto nuovo, il materiale riassorbibile si ancora profondamente alla struttura ossea creando una stabilità mai conosciuta prima. Per quanto concerne l'aumento preprotesi, il sistema è adatto ai fissaggi riassorbibili di membrana (Guided Bone Regeneration), agli accumuli (graffe onlay) e ai gusci (graffe split).

SonicWeld Rx®



Die neue Form der Resorption

SonicWeld Rx® ist das weltweit einzige resorbierbare Osteosynthesystem der MKG-Chirurgie, welches vollständig auf eine Aktivierung mit Ultraschall aufbaut. Durch die Stimulierung eines resorbierbaren Pins mit einer Sonotrode verflüssigt sich ein SonicPin Rx an dessen Oberfläche und dringt so tief in die Hohlräume des Lagerknochens vor. So wird eine bislang ungekannte Primärstabilität erzielt. Durch die Axialbewegung beim Einbringen der Pins gehören Verlagerungen und Schraubenbrüche der Vergangenheit an. Darüber hinaus lassen sich jetzt auch spongiöse Knochenstrukturen für die Verankerung von resorbierbaren Implantaten nutzen. Mehr noch: Der Kopf des SonicPins Rx verbindet sich wie ein Verriegelungssystem mit der Platte und bildet mit dieser nach dem Verschmelzen eine Einheit.

The new Form of Resorption

SonicWeld Rx® is the only resorbable OMF osteosynthesis system in the world that entirely relies on ultrasound for activation. By stimulating an absorbable "SonicPin Rx" with a sonotrode, the pin's surface liquefies to an extent that it is capable of penetrating deeply into the cavities of the supporting bone. The result is a basic stability previously unknown. Thanks to a completely axial movement of the pin during insertion, displacements and screw fractures are definitely a thing of the past. Besides, it is now possible to use even cancellous bone structures for secure anchorage of these absorbable implants. And what is more, the head of the SonicPin Rx neatly unites with the surface of the implant to form a perfect interlock.

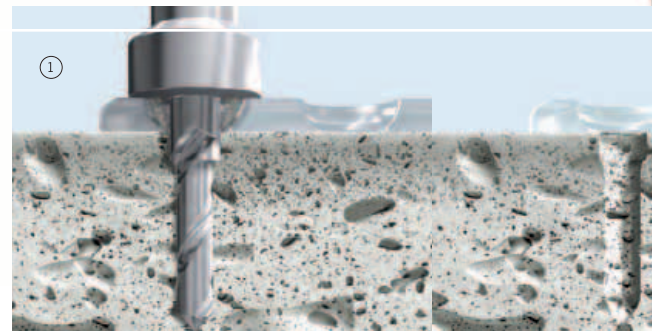

So einfach funktioniert die Osteosynthese mit SonicWeld Rx®: Platte/Mesh erwärmen und anpassen (1), Loch vorbohren (2) und SonicPin Rx aufsetzen (3). Die Sonotrode bringt den SonicPin Rx mittels Ultraschall zur Verflüssigung an der Oberfläche und somit zum Eingleiten (4), der SonicPin Rx verbindet sich mit der Platte/Mesh und dringt tief in die knöchernen Hohlräume ein (5).

La nueva forma de la reabsorción

SonicWeld Rx® es el único sistema de osteosíntesis reabsorbible de la cirugía oral y maxilofacial del mundo que se basa por completo en una activación por ultrasonidos. Mediante la estimulación de un pin reabsorbible con un sonotrodo, el SonicPin Rx se licúa en la superficie del hueso, penetrando a continuación en profundidad dentro de las cavidades del tejido óseo. Con esto se consigue una estabilidad original hasta ahora desconocida. Gracias al movimiento lineal durante la introducción del pin, las desviaciones y roturas de los tornillos son cosa del pasado. Otra ventaja adicional es que ahora también pueden utilizarse estructuras óseas esponjosas para el anclaje de implantes reabsorbibles. Y, además, la cabeza del SonicPin Rx se une como un sistema de bloqueo con la superficie del implante.

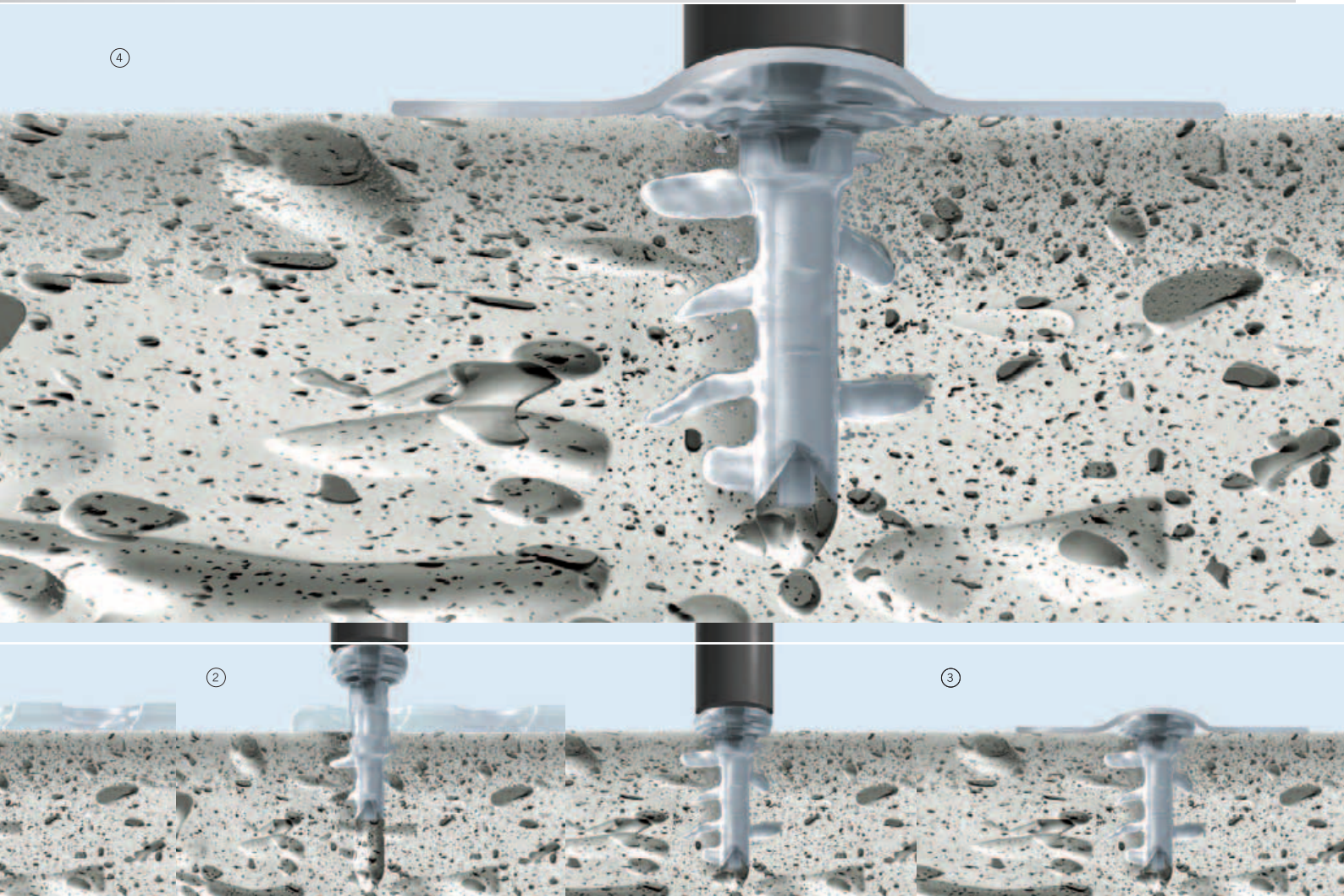
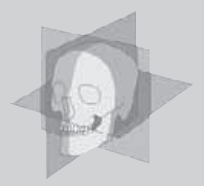

Osteosynthesis with SonicWeld Rx® – a very simple procedure: warm up and adapt the plate/mesh (1), predrill the hole (2) and insert the SonicPin Rx (3). The sonotrode's ultrasonic vibrations cause the SonicPin Rx to melt on the surface and glide into the predrilled hole (4). In this process, the SonicPin Rx combines with the plate/mesh and penetrates into all bone cavities (5).

Osteosintesis con SonicWeld Rx® – un procedimiento muy simple: debe calentarse y adaptar la placa/malla (1) a la superficie ósea, perforar el taladro (2) y colocar el SonicPin Rx (3). Los ultrasonidos del sonotrodo hacen que el SonicPin Rx se licúe en la superficie, fluyendo hacia el interior del taladro (4). En este proceso, el SonicPin Rx se fusiona con la placa/rejilla y penetra en las cavidades óseas (5).

L'ostéosynthèse avec SonicWeld Rx® fonctionne très simplement: chauffer la plaque/le mesh et ajuster (1), percer un avant-trou (2) et poser le SonicPin Rx dessus (3). Le sonotrode fait fondre la surface du SonicPin Rx avec des ultrasons, il glisse alors dans l'avant-trou (4). Le SonicPin Rx se lie à la plaque/au mesh et pénètre dans les cavités osseuses (5).

L'osteosintesi con il SonicWeld Rx® funziona semplicemente così: riscaldare la placca/mesh e adattarla (1), realizzare il foro preliminare (2) ed inserire il SonicPin Rx (3). L'elettrodo ad ultrasuoni porta il SonicPin Rx, per mezzo degli ultrasuoni, allo scioglimento della superficie e ne permette l'introduzione nel foro preliminare (4), il SonicPin Rx si salda alla placca/mesh e penetra nelle cavità ossee (5).

La nouvelle forme de la résorption

SonicWeld Rx® est le seul système d'ostéosynthèse résorbable au monde de chirurgie orale et maxillofaciale qui repose complètement sur une activation aux ultrasons. Sous l'effet de la stimulation d'un pin résorbable avec une sonotrode, un SonicPin Rx se liquéfie à sa surface et pénètre ainsi profondément dans les cavités de l'os de support. Ceci permet d'obtenir une stabilité de base inconnue jusqu'ici. Grâce au mouvement rectiligne lors de l'insertion des pins, les déplacements et les ruptures de vis font partie du passé. Par ailleurs, des structures osseuses spongieuses peuvent maintenant également être utilisées pour l'ancrage d'implants résorbables. Plus encore: la tête du SonicPin Rx se relie comme un système de verrouillage avec la surface de l'implant.

La nuova forma del riassorbimento

SonicWeld Rx® è l'unico sistema di osteosintesi riassorbibile a livello mondiale della chirurgia orale e maxillo-facciale, che si basa completamente su una attivazione ad ultrasuoni. Mediante la stimolazione di un pin riassorbibile "SonicPin Rx" con un sonotrodo la superficie di questo si scioglie così tanto da penetrare in profondità nelle cavità ossee. In questo modo si crea una osteosintesi estremamente stabile. Grazie all'introduzione del pin con scivolamento assiale, sono scongiurate rotture dei pin. Il fissaggio dei pin può essere inoltrato anche negli strati ossei spugnosi, con ulteriore incremento di stabilità. La testa del SonicPin Rx si ancora, come un dispositivo di bloccaggio, all'intera placca, formando insieme ad essa, a saldatura avvenuta, un'unica unità.

Das Programm mit System

The program with a system

La gama con sistema

La gamme systématisée

Il programma con un sistema



SonicPins Rx

- Verfügbar in den Durchmessern 1,6 mm und 2,1 mm
- Die optimale Form der SonicPins Rx garantiert einerseits ein leichtes Einbringen und andererseits eine stabile Verankerung am Knochen
- Diameters of 1.6 mm and 2.1 mm.
- The optimized shape of the SonicPins Rx guarantees easy insertion and strong fixation in the bone
- Disponible en diámetros de 1,6 mm y 2,1 mm
- La forma optimizada de los SonicPins Rx garantiza una inserción sencilla y una fuerte fijación en el hueso
- Diamètres de 1,6 mm et 2,1 mm
- La forme optimale des SonicPins Rx garantit une insertion aisée et une fixation stable dans l'os
- Disponibile nei diametri 1,6 mm e 2,1 mm
- La forma ottimale dei SonicPin Rx garantisce da un lato un facile inserimento e dall'altro un ancoraggio stabile alle ossa



Membran und Meshes

- Intrinsisch amorphe PDLLA-Membran und Meshes
- Komplet transparent – optimale Übersicht
- Ideale Biegeeigenschaften unter Wärmeinfluss
- Einmal fixiert ist die Membran oder das Mesh dreidimensional stabil und resistent gegen Druckkräfte

Membrane and meshes

- Intrinsically amorphous PDLLA membrane and meshes
- Completely transparent – optimal overview
- Ideal bending properties under heat
- Once fixed in place, the membrane or mesh provides three-dimensional stability and is resistant to compressive forces as well

Membrana y mallas

- Membrana y mallas de PDLLA intrínsecamente amorfas
- Completamente transparentes – visión óptima
- Propiedades de doblado ideales bajo calor
- Una vez fijada, la membrana o malla presenta estabilidad tridimensional y es resistente a las fuerzas de compresión

Membrane et meshes

- Membrane et meshes amorphes intrinsèques en PDLLA
- Complètement transparents – vue d'ensemble optimale
- Propriétés de flexion idéale sous l'effet de la chaleur
- Une fois fixé, la membrane ou le mesh présente une stabilité tridimensionnelle et résiste aux forces de pression

Membrana e mesh

- Membrana e mesh PDLLA intrinsecamente amorf
- Completamente trasparente – visione ottimale
- Proprietà ideali di piegatura sotto l'influsso del calore
- Una volta fissata la membrana o la mesh forniscono stabilità tridimensionale e resistono alle forze di compressione



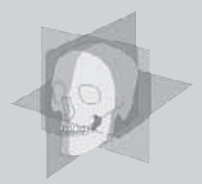

Winkelsonotrode

- Ermöglicht ein sicheres Arbeiten an schwer zugänglichen Regionen wie z.B. dem Seitenzahnbereich

Angled sonotrode

- Enables safe working in regions that are hard to access (such as the lateral tooth region)

Sonotrodo acodado

- Posibilita trabajar con seguridad en regiones de difícil acceso como, por ejemplo, en la región dental lateral

Sonotrode coudée

- Permet de travailler en toute sécurité dans des régions difficilement accessibles (par ex. la région des dents postérieures)

Elettrodo ultrasonico angolato

- Consente di lavorare in sicurezza in regioni di difficile accesso come per esempio la regione laterale dei denti



SonicWelder Rx

- Verschiedene vorprogrammierte Anwendungsstufen sowie manuelle Einstellmöglichkeiten lassen den Chirurgen jede klinische Anforderung beherrschen.
- Leicht zu bedienen durch übersichtliche Menüführung.

- A number of pre-programmed application levels plus manual setting options enable the surgeon to master any clinical task.
- Easy to operate thanks to straightforward menu control.

- Diferentes niveles de aplicación programados previamente y las posibilidades de ajuste manuales permiten que el cirujano domine cualquier exigencia clínica.
- Operación sencilla gracias al inequívoco modo menú.

- Différents niveaux d'application pré-programmés ainsi que des options de réglage manuel permettent au chirurgien de maîtriser tous les gestes cliniques.
- Facile à utiliser grâce à un guidage par menu clair.

- Diversi livelli di applicazione preprogrammati e la possibilità di regolazione manuale consentono al chirurgo di avere padronanza dei compiti clinici.
- Facile da comandare grazie al controllo diretto da menu.



Glättsonotroden

- Garantieren eine perfekte Ankonturierung der Membran an die Knochenoberfläche
- Zusammenschweißen mehrerer Membrane zu einer Einheit

Smoothing sonotrodes

- Guarantee perfect adaptation of the membrane to the bone surface
- Several membranes can be welded together to form a unit

Sonotrodos de alisado

- Garantizan un contorneado perfecto de la membrana a la superficie ósea
- Soldado de varias membranas para formar una unidad

Sonotrodes de lissage

- Garantissent l'adaptation parfaite de la membrane aux contours de la surface osseuse
- Plusieurs membranes peuvent être soudées pour former une unité

Elettrodi ultrasonici di lisciatura

- Garantiscono un perfetto adattamento della membrana alla superficie delle ossa
- Varie membrane possono essere saldate insieme a formare un'unità

Membranfixierung und Guided Bone Regeneration

Membrane fixation and Guided Bone Regeneration

Fijación de membranas y Guided Bone Regeneration (regeneración ósea guiada)

Fixation de membrane et Guided Bone Regeneration

Fissaggio di membrana e Guided Bone Regeneration

Membranfixierung und Guided Bone Regeneration

Resorbierbare Membranen sind heute in Membranfixierung und Guided Bone Regeneration Stand der Technik. Der Raum, in dem neuer Knochen generiert werden soll, muss zuverlässig mit einer Membran geschützt werden. Die reine PDLLA-Membran hat eine verlässlich hohe dreidimensionale Ursprungsfestigkeit bei gleichzeitig sicherem Abbauverhalten. Schnell wachsende Bindegewebszellen werden sicher von langsamer wachsenden Knochenzellen abgeschirmt.

Membrane fixation and Guided Bone Regeneration (GBR)

Resorbable membranes currently represent the state of the art in membrane fixation and Guided Bone Regeneration. In these procedures, the space intended for generating new bone must be securely protected by a membrane. Pure PDLLA membranes offer reliably high, three-dimensional original strength while their biodegradability is guaranteed at the same time. Thus, rapidly growing connective tissue cells are safely shielded off from the slower-growing bone cells.

Fijación de membranas y Guided Bone Regeneration (regeneración ósea guiada)

Las membranas reabsorbibles en la actualidad representan el estado de la técnica en la fijación de membranas y la regeneración ósea guiada (Guided Bone Regeneration). En estos procedimientos, el espacio previsto para la generación de hueso nuevo debe ser protegido de manera fiable con una membrana. La membrana pura de PDLLA presenta una resistencia tridimensional original alta y fiable, estando además asegurada su biodegradabilidad. De este modo, se asegura el apantallamiento de las células óseas de crecimiento más lento frente a las células de crecimiento rápido del tejido conjuntivo.

Fallbeispiele* • Case examples* • Ejemplos prácticos* • Exemples de cas* • Casi esemplari*



Fall 1: 71-jährige Patientin mit 1-Zahn-Defekt frontal

Case 1: 71-year-old female patient with single-tooth defect in frontal region

Caso 1: Paciente de 71 años con defecto de diente único en la región frontal

Cas 1: patiente de 71 ans avec défaut sur une dent frontale

Primo caso: Paziente donna di 71 anni con 1 difetto dentale frontale



Vorboren des Implantatlagers und Setzen der lateralen SonicPins Rx.

Pre-drilling for implant bed preparation and placement of the lateral SonicPins Rx.

Taladrado previo del lecho de implantación y colocación de los SonicPins Rx laterales.

Préforage du site d'implantation et mise en place des SonicPins Rx latéraux

Preperforazione del supporto dell'implianto ed applicazione di SonicPins Rx laterali.



- Die 0,1-mm-Membran bietet völlige Transparenz zu jedem Zeitpunkt.
- Ursprünglich sehr gute Konturierbarkeit
- Einmal angeschweißt wird sie das Augmentat formstabil decken.
- The 0.1-mm-thick membrane provides 100% transparency at any time.
- Very easy to shape and adapt in its original condition.
- Once welded in place, it will retain its dimensional stability and cover the augmentate reliably.
- La membrana de 0,1 mm de grosor ofrece transparencia absoluta en todo momento.
- Muy fácil de contornear y adaptar en su estado original
- Una vez soldada en su posición, mantendrá su estabilidad dimensional y cubrirá el aumento de forma fiable.
- La membrane de 0,1 mm offre une parfaite transparence à tout moment.
- Mise en forme très aisée à l'état d'origine
- Une fois mise en place et soudée, elle conservera sa forme et recouvrira le matériel de comblement de manière fiable.
- La membrana da 0,1 mm offre la massima trasparenza in qualsiasi momento.
- Contorni originariamente molto ben delineabili.
- Dopo la saldatura, la membrana ricopre stabilmente l'aumento osseo.



Fall 2: Sinusliftverfahren mit SonicWeld Rx®
Zunächst wird der Sinus in Window-Technik ausreichend präpariert.

Case 2: Sinus lift procedure with SonicWeld Rx®
In a first step, the sinus is sufficiently dissected using the window technique.

Caso 2: Procedimiento de elevación del seno con SonicWeld Rx®
En un primer paso, el seno es suficientemente preparado mediante la técnica "window" (ventana).

Cas 2: procédé de sinus lift avec SonicWeld Rx®
Le sinus est tout d'abord bien préparé en utilisant la technique de fenêtre.

Secondo caso: Procedimento di rialzo del seno mascellare con SonicWeld Rx®
Innanzitutto viene preparato il seno mascellare con la tecnica a finestra.

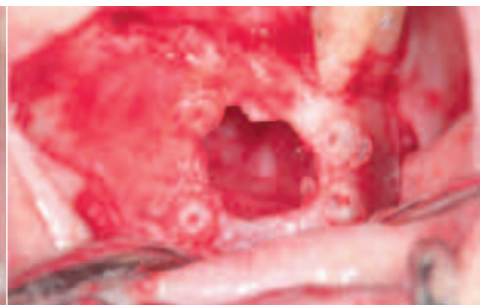

Dann werden rings um den Sinus die SonicPins Rx eingeschweißt.

Thereafter, the SonicPins Rx are welded in place around the sinus.

A continuación se sellan los SonicPins Rx alrededor del seno.

Les SonicPins Rx sont ensuite soudés autour du sinus.

In seguito vengono saldati i SonicPins Rx intorno al seno mascellare.

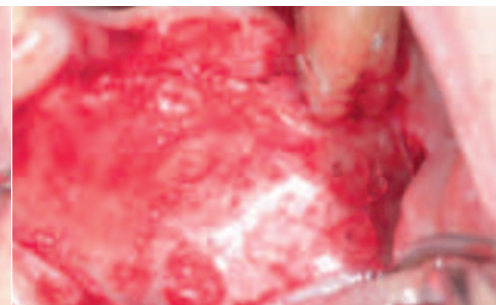

Erst jetzt wird das Augmentat in den Sinus eingebracht. Anschließend wird der Sinus durch eine 0,1 mm dünne Membran sicher aufgeschweißt.

Only now is the augmentate inserted into the sinus. Then a membrane with a thickness of just 0.1 mm is welded in place to cover the site.

Sólo ahora se introduce el aumento dentro del seno. Acto seguido se suelda una membrana de tan sólo 0,1 mm de grosor en el lugar para cubrir la posición.

Ce n'est qu'alors que le matériel de comblement est inséré dans le sinus. Une membrane épaisse de 0,1 mm est ensuite soudée pour couvrir le site.

Solo a questo punto viene inserito l'aumento osseo nel seno mascellare. Per concludere il sito viene sigillato tramite una membrana sottile dello spessore di 0,1 mm.

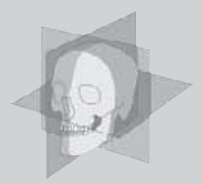

Fixation de membrane et Guided Bone Regeneration

Les membranes résorbables sont aujourd'hui à la pointe de la technique en termes de fixation de membrane et de Guided Bone Regeneration. L'espace dans lequel de l'os nouveau doit être générés doit être protégé de manière fiable par une membrane. La membrane en 100 % PLLA est tridimensionnellement très résistante dans son état d'origine, tout en assurant une bonne biodégradabilité. Des cellules de tissu conjonctif à croissance rapide sont séparées de manière sûre de cellules osseuses à croissance plus lente.

Fissaggio di membrana e Guided Bone Regeneration

Le membrane riassorbibili costituiscono lo stato attuale della tecnica per quanto riguarda il fissaggio di membrana e la Guided Bone Regeneration. Lo spazio in cui è prevista la rigenerazione ossea deve essere protetto in modo affidabile da una membrana. La membrana pura PLLA è dotata di un'elevata ed affidabile stabilità tridimensionale di origine ed offre al contempo un processo di smaltimento sicuro. Le cellule del tessuto connettivo a crescita rapida vengono schermate dalle cellule ossee, a crescita più lenta.



Nach Wundverschluss.

Condition after wound closure

Después del cierre de la herida

Après fermeture de la plaie

Dopo la rimarginazione della ferita



52-501-03

Glättsonotrode, gerade
Smoothing sonotrode, straight
Sonotrodo de alisado, recto
Sonotrode de lissage, droite
Elettrodo ultrasonico di lisciatura, diritto



52-501-04



Glättsonotrode, gewinkelt
Smoothing sonotrode, angled
Sonotrodo de alisado, acodado
Sonotrode de lissage, coudée
Elettrodo ultrasonico di lisciatura, angolato

Bestellempfehlung Order recommendation Recomendación de pedido Recomandación de commande Suggerimento di ordine

SonicPins Rx			
	1.6 x 4 mm	52-516-24 ² <small>unit</small>	52-516-54 ⁵ <small>unit</small>
	1.6 x 5 mm	52-516-25 ² <small>unit</small>	52-516-55 ⁵ <small>unit</small>
	2.1 x 4 mm	52-521-24 ² <small>unit</small>	52-521-54 ⁵ <small>unit</small>
	2.1 x 5 mm	52-521-25 ² <small>unit</small>	52-521-55 ⁵ <small>unit</small>

Resorb x® membrane t=0.1 mm	
	25 x 25 mm 52-301-28 ¹ <small>unit</small>

Vorbohrer, Twist drills, Brocas, Mèches de préforage, Frese Dental-Ansatz/Dental attachment/Sujeción tipo dental/ Embout dentaire/Connessione dentale

	für/for/para/pour/per 1.6 mm SonicPins Rx		
	Ø x L (mm)	Stop (mm)	
	1.0 x 20	5	52-509-05 St ¹ <small>unit</small>
	1.0 x 20	6	52-509-06 St ¹ <small>unit</small>
	für/for/para/pour/per 2.1 mm SonicPins Rx		
	Ø x L (mm)	Stop (mm)	
	1.6 x 20	5	52-515-05 St ¹ <small>unit</small>
	1.6 x 20	6	52-515-06 St ¹ <small>unit</small>

* Fallbilder von Dr. Ulrich Volz, Konstanz
Case photos provided by Dr. Ulrich Volz, Constance (Germany)
Imágenes de los casos por cortesía del Dr. Ulrich Volz, Konstanz
Photos de cas fournies par le Dr Ulrich Volz, Constance
Immagini dei casi esemplari fornite dal Dr. Ulrich Volz di Constanza

Auflagerungen – Onlay Grafts

Appositions – Onlay grafts

Aposiciones – Onlay Grafts

Greffes d'apposition – Onlay Grafts

Accumuli - Graffe onlay

Onlay Grafts

Auflagerungen von Knochenblöckchen nach dem Zugschraubenprinzip mit längeren SonicPins Rx. Die Bohrer-geometrien von Kern- und Gleitloch sind dabei streng zu unterscheiden.

Kernloch Ø 1,6 mm für SonicPins Rx Ø 2,1 mm
Core hole Ø 1.6 mm for SonicPins Rx Ø 2.1 mm
Ø taladro para roscar 1,6 mm para SonicPins Rx con Ø 2,1 mm
Avant-trou, Ø 1,6 mm, pour SonicPins Rx Ø 2,1 mm
Preforo Ø 1,6 mm per SonicPins Rx Ø 2,1 mm

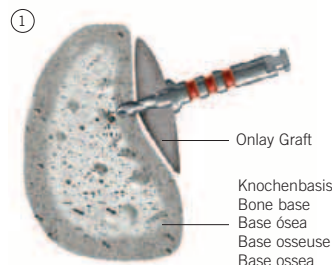

Onlay Grafts

Apposition of small bone blocks according to the lag screw principle, using relatively long SonicPins Rx. It is important to differentiate strictly between the geometries of the drill bits used for core holes on the one hand and gliding holes on the other hand.

Gleitloch Ø 2,1 mm
Gliding hole Ø 2.1 mm
Ø taladro deslizante 2,1 mm
Trou de glissement Ø 2,1 mm
Foro di scorrimento Ø 2,1 mm

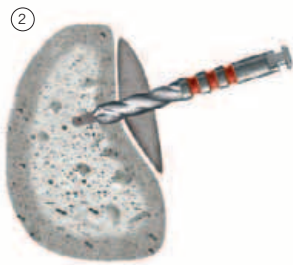

Onlay Grafts

Aposiciones de pequeños bloques óseos conforme al principio del tornillo de tracción, utilizando SonicPins Rx relativamente largos. En este caso resulta importante diferenciar estrictamente entre las geometrías de las brocas utilizadas por un lado para el taladro para roscar y, por el otro, para el taladro deslizante.

Pin kann sich nur im Kernloch verschmelzen.
Bone Graft wird herangezogen.

Pin can sink into core hole only.
Bone graft is pulled in place.

El pin sólo puede fundirse en el taladro para roscar. El injerto óseo (bone graft) es traccionado hacia la posición definitiva.

Le pin ne peut s'enfoncer que dans l'avant-trou.
La greffe osseuse est mise en place par traction.

Il pin può fondersi solamente nel preforo tirando la graffa per innesto osseo Bone Graft .



Fallbeispiel* • Case example* • Ejemplo práctico* • Exemple de cas* • Caso esemplare*



Typischer traumatischer Frontzahndefekt im Oberkiefer
Typical traumatic anterior tooth defect in the maxilla
Defecto típico traumático de diente anterior en el maxilar superior
Défaut traumatique typique d'une dent antérieure du maxillaire supérieur
Tipico difetto traumatico di dente frontale nella mandibola superiore

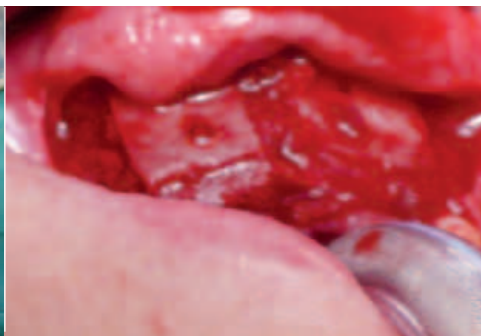

Seitliches Auflagern von zwei Onlay Grafts und deren Fixierung mit SonicWeld Rx®
Lateral apposition of two onlay grafts, fixed in place with SonicWeld Rx®
Aposición lateral de dos Onlay Grafts y su fijación con SonicWeld Rx®
Apposition latérale de deux greffes (Onlay Grafts) fixées avec SonicWeld Rx®
Accumulo laterale di due graffe Onlay e fissaggio delle stesse con SonicWeld Rx®

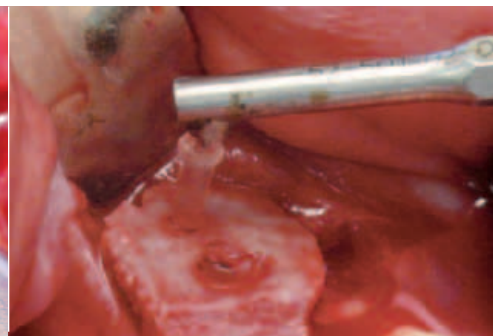

Bei schwierigen Zugängen kann die Verwendung der Winkelsonotrode sehr hilfreich sein
Where access is difficult, an angled sonotrode can be very helpful
En el caso de accesos difíciles puede resultar muy útil la utilización del sonotrodo acodado
En cas d'accès difficile, l'utilisation de la sonotrode angulaire peut s'avérer très utile
In caso di accesso difficile può essere molto utile l'utilizzo del sonotrodo angolato

* Fallbilder von Dr. Richard Loukota, GB-Leeds
Case pictures furnished by Dr. Richard Loukota, Leeds (UK)
Imágenes del caso por cortesía del Dr. Richard Loukota, Leeds (UK)
Photos de cas fournies par le Dr Richard Loukota, Leeds (Grande-Bretagne)
Immagini dei casi esemplari fornite dal Dr. Richard Loukota, Leeds (UK)



Onlay Grafts

Greffes d'apposition de petits blocs osseux selon le principe de la vis de traction avec des SonicPins Rx relativement longs.

Il faut bien faire la différence entre les géométries des forets utilisés pour l'avant-trou et pour le trou de glissement.

Onlay Grafts



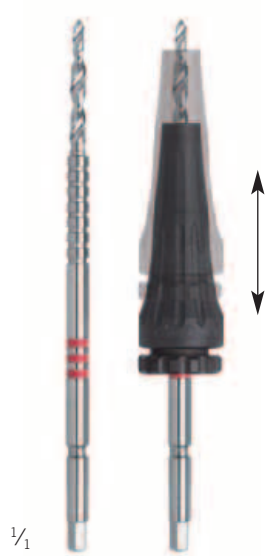
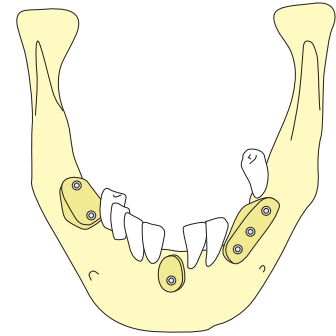

Accumuli di piccoli blocchi ossei secondo il principio delle viti mordenti con SonicPins Rx più lunghi. Le geo-metrie delle punte del preforo e del foro di scorrimento devono essere distinte chiaramente.















1/1





Stufenbohrer
Step drill
Broca bidiametral
Foret étagé
Fresa a livelli





Bestellempfehlung Order recommendation Recomendación de pedido Recommandation de commande Suggerimento di ordine

SonicPins Rx		
	2.1 x 11 mm	52-521-31 
	2.1 x 13 mm	52-521-33 
	2.1 x 15 mm	52-521-35 
	2.1 x 17 mm	52-521-37 

Vorböhrer, Twist drills, Brocas, Mèches de préforage, Frese Dental-Ansatz/Dental attachment/Sujeción tipo dental/Embout dentaire/Connessione dentale Kernlochbohrer, Core hole drill, Broca para taladro de roscar, Foret pour avant-trou, Fresa nucleo für/for/para/pour/per 2.1 mm SonicPins Rx			
	Ø x L (mm)	Stop (mm)	
	1.6 x 20	5	52-515-05  
	1.6 x 20	6	52-515-06  
	1.6 x 20	10	52-515-10  
	1.6 x 35	20	52-515-20  

Gleitlochbohrer, Gliding hole drill, Broca para taladro deslizante, Foret pour trou de glissement, Fresa a scorrimento für/for/para/pour/per 2.1 mm SonicPins Rx			
	Ø x L (mm)	Stop (mm)	
	2.1 x 24	12	52-522-10  

Stufenbohrer, Step drill, Broca bidiametral, Foret étagé, Fresa a livelli für/for/para/pour/per 2.1 mm SonicPins Rx Stryker-Ansatz/Stryker attachment/Sujeción tipo Stryker/Embout Stryker/Connessione Stryker			
	Ø x L (mm)	Stop (mm)	
	1.6 x 70	verstellbar/adjustable/ ajustable/réglable/ regolabile	52-516-51   ohne Verstellhülse / w/o adjusting sleeve / sin casquillo de ajuste / sans écrou moleté / senza manicotto di regolazione
			52-516-60  Verstellhülse / adjusting sleeve / casquillo de ajuste écrou moleté / manicotto di regolazione

BOS-Ansatz/BOS attachment/Sujeción tipo BOS/Embout BOS/Connessione BOS			
	Ø x L (mm)	Stop (mm)	
	1.6 x 70	verstellbar/adjustable/ ajustable/réglable/ regolabile	52-516-52   ohne Verstellhülse / w/o adjusting sleeve / sin casquillo de ajuste / sans écrou moleté / senza manicotto di regolazione
			52-516-60  Verstellhülse / adjusting sleeve / casquillo de ajuste écrou moleté / manicotto di regolazione

Schalentechnik nach Dr. Iglhaut

Shell technique acc. to Dr. Iglhaut

Técnica de valva según Dr. Iglhaut

Technique à coquille selon Dr. Iglhaut

Tecnica a guscio secondo Dr. Iglhaut

Schalentechnik nach Dr. Iglhaut

Ein völlig neuer Ansatz stellt die Schalentechnik nach Dr. Iglhaut dar. Sie baut bewusst auf die Rigidität der PDLLA-Membranen auf und nutzt sie zum lateralen Volumengewinn. Die nötigen SonicPins Rx werden vorfixiert und die Membran aufgeschweißt. Partikulierter Eigenknochen und Knochenersatzmaterialien bilden das Augmentat. Der crestale Abschluss zum Kieferkamm wird durch diffusionsoffene Collagenmembranen erzielt. Sie haben die beste Weichgewebs-toleranz und wirken möglichen Dehiszenzen entgegen. Durch die Schalentechnik wird die aufwändige Präparationstechnik des Knochensplittings und das Resorptionsrisiko ausgelagerter Knochenblöckchen vermieden.

Shell technique acc. to Dr. Iglhaut

A completely novel approach must be seen in the "shell" technique invented by Dr. Iglhaut. It makes conscious use of the rigidity of PDLLA membranes for building lateral volume. The required SonicPins Rx are prefixed and the membrane is then welded in place. Particulate autogenous bone and bone substitute materials are used for the augmentate. Crestal close-off against the alveolar ridge is achieved with diffusion-open collagen membranes. These membranes offer the best soft tissue tolerance and counteract potential dehiscences. The "shell" technique not only avoids time-consuming dissection by bone splitting, but also eliminates the resorption risk associated with the transplantation of small bone blocks.

Técnica de valva según Dr. Iglhaut

Un planteamiento totalmente nuevo lo representa la técnica de "valva" inventada por el Dr. Iglhaut. Hace una utilización consciente de la rigidez de las membranas de PDLLA para conseguir un incremento volumétrico lateral. Los SonicPins Rx necesarios se fijan previamente y, a continuación, se suelda la membrana en la posición definida. El aumento está formado por tejido óseo autólogo particulado y materia-les sustitutorios del hueso. El cierre de la cresta hacia la apófisis alveolar se consigue mediante membranas de colágeno abiertas a la difusión. Éstas ofrecen la mejor tolerancia con tejidos blandos y contrarrestan posibles dehiscencias. Gracias a la técnica de valva se evita la complicada técnica de preparación de la partición ósea (splitting) y el riesgo de reabsorción de pequeños bloques óseos transplantados.

Fallbeispiel* • Case example* • Ejemplo práctico* • Exemple de cas* • Caso esemplare*



Ausgangssituation eines bukkalen Defektes in regio 34-36

Original situation of a buccal defect in region 34-36

Situación de partida de un defecto bucal en la región 34-36

Situation initiale d'un défaut buccal dans la région 34-36

Situazione di partenza di un difetto boccale nella regione 34-36



Seitlich unterstützte Sofortimplantation der 0,1-mm-PDLLA-Membran

Laterally supported immediate implantation of the 0.1-mm PDLLA membrane

Implante inmediato de la membrana de PDLLA de 0,1 mm soportada lateralmente

Implantation immédiate avec support latéral de la membrane de 0,1 mm en PDLLA

Impianto immediato, con sostegno laterale, della membrana PDLLA da 0,1 mm



Komplette 3D-Volumenrekonstruktion

Complete 3D volume reconstruction

Reconstrucción volumétrica 3D completa

Reconstruction de volume complète en 3D

Completa ricostruzione tridimensionale del volume



Ein spannungsfreier Wundverschluss sind Schlüsselfaktoren.

Tension-free wound closure is key.

Un cierre de la herida exento de tensiones es clave.

Une fermeture sans tension de la plaie est un facteur clé.

Fattore chiave è la rimarginazione della ferita senza tensione.



Auch 6 Monate nach der OP ist das Rekonstruktionsergebnis stabil.

Stable reconstruction result even 6 months after the operation.

Incluso 6 meses después de la operación se mantiene estable el resultado de reconstrucción.

Le résultat de la reconstruction est toujours stable 6 mois après l'intervention.

Anche a 6 mesi dall'operazione il risultato della ricostruzione è stabile.

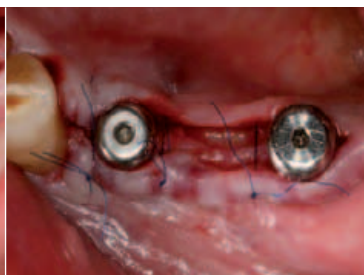

Verschiebelappenplastik für eine stabile Weichgewebsstruktur

Advancement flap plasty for stable soft tissue structure

Operación plástica de colgajo de avance para una estructura estable de tejidos blandos.

Plastie du lambeau de glissement pour une structure stable des tissus mous

Plastica del lembo di scorrimento per una struttura stabile del tessuto molle



Prothetische Versorgung

Prosthesis in place

Prótesis ubicada en su lugar

Prothèse en place

Alimentazione protesica

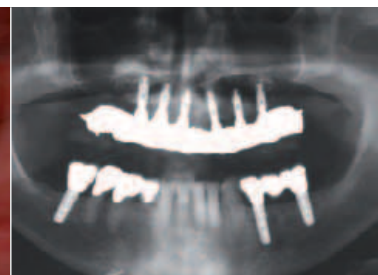

OPG 1 Jahr post OP

OPG 1 year after the operation

OPG un año después de la operación

OPT 1 an après l'intervention

OPG (radiografia panoramica) 1 anno dopo l'intervento

* Fallbilder von Dr. Gerhard Iglhaut, D-Memmingen
Case photos provided by Dr. Gerhard Iglhaut, Memmingen (Germany)
Imágenes del caso por cortesía del Dr. Gerhard Iglhaut, Memmingen (Alemania)
Photos of cas fournies par le Dr Gerhard Iglhaut, Memmingen (Allemagne)
Immagini dei casi esemplari fornite dal Dr. Gerhard Iglhaut di Memmingen (Germania)

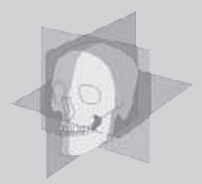

Technique à coquille selon Dr. Iglhaut

La technique à coquille selon Dr. Iglhaut constitue une approche totalement nouvelle. Elle est délibérément basée sur la rigidité des membranes en PDLA, qu'elle exploite pour obtenir un gain de volume latéral. Les SonicPins Rx nécessaires sont préalablement fixés et la membrane est soudée dessus. Des particules osseuses autogènes et des substituts osseux sont utilisés comme matériel de comblement. La fermeture de la crête par rapport au bord alvéolaire est obtenue grâce à des membranes en collagène perméables à la vapeur. Elles sont les mieux tolérées par les tissus mous et empêchent des déhiscences possibles. La technique à coquille permet d'éviter la technique de préparation complexe du «bone splitting», ainsi que le risque de résorption de petits blocs osseux transplantés.

Tecnica a guscio secondo Dr. Iglhaut

Un approccio del tutto nuovo è costituito dalla tecnica a guscio secondo Dr. Iglhaut. Essa si basa volutamente sulla rigidità delle membrane PDLA, che sfrutta per ottenere un aumento del volume laterale. I SonicPins Rx necessari vengono prefissati e saldati alla membrana. L'osso frammentato autogeno ed i materiali di sostituzione ossea costituiscono l'aumento osseo. La chiusura crestale della cresta mascellare si ottiene con membrane di collagene a diffusione aperta. Esse offrono la migliore tollerabilità al tessuto morbido e reagiscono contro eventuali deiscenze. Tramite la tecnica a guscio si evitano la dispendiosa tecnica preparatoria dello splitting osseo ed il rischio di riassorbimento di blocchi ossei trapiantati.

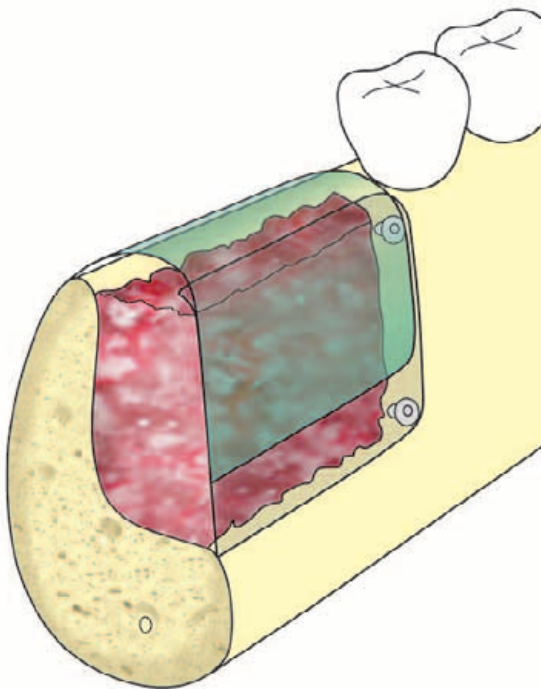

- Collagenmembran für den crestalen Abschluss
Collagen membrane for crestal augmentation
Membrana de colágeno para la estructuración de la cresta
Membrane de collagène pour l'augmentation crestale
Membrana di collagene per l'aumento crestale
- PDLA Mesh zur seitlichen Stützung (Schalung)
PDLA mesh for lateral support (shell technique)
Mesh PDLA para la sustentación lateral (técnica de valva)
Mesh en PDLA pour le support latéral (technique à coquille)
Mesh PDLA per il sostegno laterale (guscio)

Bestellempfehlung Order recommendation Recomendación de pedido Recommandation de commande Suggerimento di ordine



SonicPins Rx

1.6 x 4 mm	52-516-24 ² _{mm}	52-516-54 ⁵ _{mm}
1.6 x 5 mm	52-516-25 ² _{mm}	52-516-55 ⁵ _{mm}

Resorb x® membrane

25 x 25 mm, t=0.1 mm	52-301-28 ¹ _{mm}
25 x 25 mm, t=0.3 mm	52-302-25 ¹ _{mm}
50 x 50 mm, t=0.3 mm	52-303-50 ¹ _{mm}



Vorbohrer, Twist drills, Brocas, Mèches de préforage, Frese

Dental-Ansatz/Dental attachment/Sujeción tipo dental/ Embout dentaire/Connessione dentale

für/for/para/pour/per 1.6 mm SonicPins Rx

Ø x L (mm)	Stop (mm)	
1.0 x 20	5	52-509-05 st ₁ _{mm}
1.0 x 20	6	52-509-06 st ₁ _{mm}

Glättsonotrode, Smoothing sonotrode, Sonotrodo de alisado Sonotrode de lissage, Elettrodo ultrasonico di lisciatura

gerade, straight, recto, droite, diritto	52-501-03 st ₁ _{mm}
gewinkelt, angled, acodado, coudée, angolato	52-501-04 st ₁ _{mm}

Bestell- und Set-Empfehlungen

Order and set recommendations

Recomendaciones de pedido y de sets

Recommandations pour les commandes et les sets

Consigli relativi all'ordinazione e alla composizione



SonicWeld Rx®

	Einheit	Designation/Unit
52-500-00	SonicWelder Basis-Set	SonicWelder basic set
	bestehend aus:	consisting of:
-	SonicWelder	SonicWelder
52-500-02	Fußschalter	Foot switch
52-500-03	Handstück	Handpiece
52-501-01	Sonotrode gerade	Sonotrode, straight
52-502-01	Gabelschlüssel für Sonotrode	Open-ended wrench for sonotrode
	separat erhältlich:	separately available:
52-501-02	Sonotrode gewinkelt	Angled sonotrode
52-501-03	Glättsonotrode gerade	Smoothing sonotrode, straight
52-501-04	Glättsonotrode gewinkelt	Smoothing sonotrode, angled
52-500-33	Verlängerungskabel, 3 m für Handstück	Extension cable, 3 m, for handpiece
52-504-00	Set Handaktivierung	Manual activation set

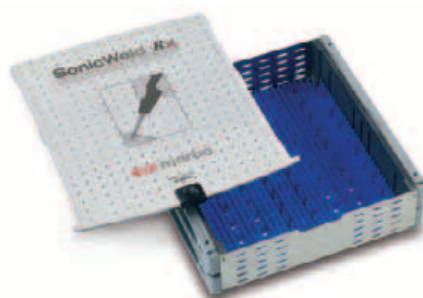

Achtung: nur für Großsterilisatoren
 Caution: for large sterilizers only
 Atención: sólo para contenedores grandes
 Attention: seul pour grands conteneurs
 Attenzione: solo per grandi sterilizzatori

Lagerungs- und Aufbewahrungstray

Storage and processing tray

	Kategorie	Umfang	Category	Scope
55-969-42	Lagerungs- und Aufbewahrungstray	komplett	Storage and processing tray	complete
	bestehend aus:		consisting of:	
55-964-30	Lagerungstray 26 x 26 cm		Storage tray 26 x 26 cm	
55-969-93	Silikonmatte		Silicone mat	
55-963-38	Deckel für Lagerungstray		Lid for storage tray	



Alternative Lagerung: Lagerungs- und Sterilisations-container für Dentalsterilisator

Alternative storage: Storage and sterilization container for dental sterilizer

	Kategorie	Category
55-861-40	<i>MicroStop</i> ® - Mini-Set-Container Außenmaße (L x B x H): 310 x 189 x 65 mm Innenmaße (L x B x H): 283 x 177 x 40 mm	<i>MicroStop</i> ® - Mini-Set container External dimensions (L x W x H): 310 x 189 x 65 mm Internal dimensions: 283 x 177 x 40 mm
55-009-00	Noppenmatte für Container	Silicone mat for container

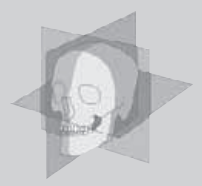

SonicWeld Rx®

	Designación/Unidad	Désignation/Unité	Denominazione/Unità
52-500-00	SonicWelder juego básico	SonicWelder set de base	Set base SonicWelder
	formado por:	composé de:	consistente in:
–	SonicWelder	SonicWelder	SonicWelder
52-500-02	Interruptor de pie	Commande à pédale	Interruttore a pedale
52-500-03	Mango	Pièce à main	Manipolo
52-501-01	Sonotrodo recto	Sonotrode droit	Elettrodo ultrasonico diritto
52-502-01	Llave de boca para el sonotrodo	Clé à fourche pour le sonotrode	Chiave fissa per l'elettrodo ultrasonico
	a pedir por separado:	à commander séparément:	da ordinarsi separatamente:
52-501-02	Sonotrodo acodado	Sonotrode coudée	Elettrodo ultrasonico angolato
52-501-03	Sonotrodo de alisado recto	Sonotrode de lissage droite	Elettrodo ultrasonico di lisciatura diritto
52-501-04	Sonotrodo de alisado acodado	Sonotrode de lissage coudée	Elettrodo ultrasonico di lisciatura angolato
52-500-33	Cable de extensión de 3 m para el mango	Câble de rallonge de 3 m pour pièce à main	Cavo di prolunga 3 m per manipolo
52-504-00	Juego de activación manual	Set d'activation manuelle	Set di attivazione manuale

Bandeja de almacenamiento y conservación

Plateau de rangement et de conservation

Bacinella di magazzino e di conservazione

	Categoría	Extensión	Catégorie	Etendue	Categoria	Entità
55-969-42	Bandeja de almacenamiento y conservación	completo	Plateau de rangement et de conservation	complet	Bacinella di magazzino e di conservazione	completa
	formado por:		composé de:		consistente in:	
55-964-30	Bandeja de almacenamiento 26 x 26 cm		Plateau de rangement 26 x 26 cm		Bacinella di magazzino 26 x 26 cm	
55-969-93	Alfombrilla de silicona		Tapis en silicone		Tappetino in silicone	
55-963-38	Tapa para la bandeja de almacenamiento		Couvercle pour plateau de rangement		Coperchio per la bacinella di magazzino	

Almacenaje alternativo: contenedor de almacenaje y esterilización para esterilizador dental

Alternative pour le rangement: conteneur de rangement et de stérilisation pour stérilisateur dentaire

Magazzino alternativo: contenitore di conservazione e di sterilizzazione nell'autoclave dentale

	Categoría	Catégorie	Categoria
55-861-40	Contenedor <i>MicroStop</i> ®, Mini-Set Dimensiones exteriores (L x A x Al): 310 x 189 x 65 mm Dimensiones interiores (L x A x Al): 283 x 177 x 40 mm	Conteneur <i>MicroStop</i> ® Mini-Set Dimensions extérieures (L x l x h) : 310 x 189 x 65 mm Dimensions intérieures (L x l x h) : 283 x 177 x 40 mm	Contenitore <i>MicroStop</i> ®, Mini-Set Dimensioni esterne (L x Largh. x A): 310 x 189 x 65 mm Dimensioni interne (L x Largh. x A): 283 x 177 x 40 mm
55-009-00	Alfombrilla de botones para contenedor	Tapis en silicone pour conteneur	Tappetino a nodi per il contenitore

Bestell- und Set-Empfehlungen

Order and set recommendations

Recomendaciones de pedido y de sets

Recommandations pour les commandes et les sets

Consigli relativi all'ordinazione e alla composizione

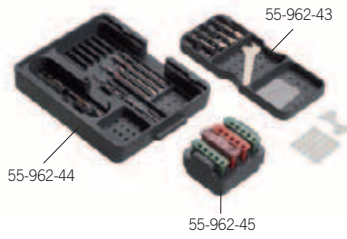

55-969-46

Komponententray (kompatibel zu Level One)		Component tray (compatible with Level One)	
Kategorie	Umfang	Category	Scope
55-969-44	Komponententray	Component tray	
bestehend aus:		consisting of:	
55-962-44	Unterteil für die Bohrer	Bottom part for drill bits	
55-962-43	Oberteil für Sonotroden und Kleinteile	Upper part for sonotrodes and small parts	
55-963-51	Schiebedeckel, transparent	Sliding cover, transparent	
Alternativ dazu:		Alternatively:	
55-969-46	Kleinteilemodul	Small parts module	
55-962-45	Lagerung für Clipmagazine	Storage rack for clip magazines	



Xcelsior-Wasserbad			Xcelsior water bath	
Kategorie	Umfang	Category	Scope	
52-400-10	Wasserbad	komplett	Water bath	complete
bestehend aus:			consisting of:	
-	Thermoeinheit	alleine	Heating unit	separate
52-400-12	Wasserbehälter	alleine	Water container	separate
52-400-13	Abdeckhaube	alleine	Cover	separate



BOS Drill		BOS Drill	
Kategorie	Category		
50-800-03	BOS Drill ohne Batteriepack	BOS Drill w/o battery pack	
50-800-02	Batteriepack, steril (je 10 Stück)	Battery pack, sterile (10 units)	

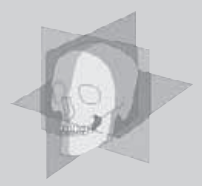

Bandeja para componentes (compatible con Level One)		Module pour composants (compatible avec Level One)		Cassetta per componenti (compatibile con Level One)	
Categoría	Extensión	Catégorie	Etendue	Categoria	Entità
55-969-44	Bandeja para componentes	Module pour composants		Cassetta per componenti	
	formado por:	composé de:		composta da:	
55-962-44	Pieza inferior para las brocas	Partie inférieure pour les forets		Parte inferiore per le punte da trapano	
55-962-43	Pieza superior para sonotrodos y piezas pequeñas	Partie supérieure pour les sonotrodes et les petites pièces		Parte superiore per sonotrodi e pezzi piccoli	
55-963-51	Tapa corrediza, transparente	Couvercle coulissant, transparent		Coperchio scorrevole, trasparente	
	De forma alternativa a lo anterior:	Alternative:		Supplemento alternativo:	
55-969-46	Módulo para piezas pequeñas	Module pour petites pièces		Modulo per pezzi piccoli	
55-962-45	Soporte de almacenaje para depósitos sujetatornillos	Rangement pour chargeurs à clips		Contenitore di conservazione per clip magazine	

Baño María Xcelsior			Bain-marie Xcelsior		Dispositivo per riscaldare e modellare le placche Xcelsior	
Categoría	Extensión	Catégorie	Etendue	Categoria	Entità	
52-400-10	Baño María completo	Bain-marie complet		Dispositivo per bagno d'acqua completo		
	formado por:	composé de:		consistente in:		
-	Unidad térmica sola	Unité thermique seul		Unità termica separata		
52-400-12	Depósito de agua sola	Cuve à eau seul		Unità per bagno d'acqua separata		
52-400-13	Cubierta sola	Couvercle seul		Calotta di protezione separata		

BOS Drill		BOS Drill		BOS Drill	
Categoría	Catégorie	Catégorie	Catégorie	Categoria	Categoria
50-800-03	BOS Drill sin bloque de pilas	BOS Drill sans bloc de piles		BOS Drill senza batterie	
50-800-02	Bloque de pilas, estéril (resp. 10 unidades)	Bloc de piles, stérile (10 unités)		Batterie, sterili (10 pezzi)	

Vorbohrer

Twist Drills

Brocas

Mèches de préforage

Frese

Vorbohrer
Twist drills
Brocas
Mèches de préforage
Frese



Stryker-Ansatz, Stryker attachment, Sujeción tipo Stryker, Embout Stryker, Connessione Stryker

für/for/para/pour/per 1.6 mm SonicPins Rx

Ø x L (mm) Stop (mm)

1.0 x 50	3	52-510-03	St	1 Länge
1.0 x 50	4	52-510-04	St	1 Länge
1.0 x 50	5	52-510-05	St	1 Länge
1.0 x 50	6	52-510-06	St	1 Länge
1.0 x 50	7	52-510-07	St	1 Länge
1.0 x 50	8	52-510-08	St	1 Länge

für/for/para/pour/per 2.1 mm SonicPins Rx

Ø x L (mm) Stop (mm)

1.6 x 50	3	52-516-03	St	1 Länge
1.6 x 50	4	52-516-04	St	1 Länge
1.6 x 50	5	52-516-05	St	1 Länge
1.6 x 50	6	52-516-06	St	1 Länge
1.6 x 50	8	52-516-08	St	1 Länge
1.6 x 50	10	52-516-10	St	1 Länge

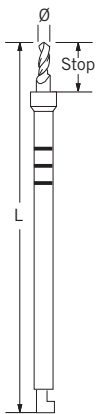

Gleitlochbohrer, Gliding hole drill, Broca para taladro deslizante, Foret pour trou de glissement, Fresa a scorrimento

für/for/para/pour/per 2.1 mm SonicPins Rx

Ø x L (mm) Stop (mm)

2.2 x 70	–	50-022-01	St	1 Länge
----------	---	-----------	----	------------



Stufenbohrer, Step drill, Broca bidiametral, Foret étagé, Fresa a livelli

für/for/para/pour/per 2.1 mm SonicPins Rx

Ø x L (mm) Stop (mm)

1.6 x 70	verstellbar / adjustable / ajustable / réglable / regolabile	52-516-51	St	1 Länge	ohne Verstellhülse / w/o adjusting sleeve / sin casquillo de ajuste / sans écrou moleté / senza manicotto di regolazione
		52-516-60	1 Länge		Verstellhülse / adjusting sleeve / casquillo de ajuste écrou moleté / manicotto di regolazione



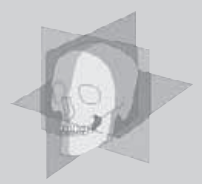

Vorbohrer
Twist drills
Brocas
Mèches de préforage
Frese



**Für BOS-Drill, Hexagonal-Ansatz/For BOS Drill, hexagonal attachment/Para BOS Drill, sujeción hexagonal/
 Pour BOS Drill, embout hexagonal/Per BOS Drill, connessione esagonale**

für/for/para/pour/per 1.6 mm SonicPins Rx

Ø x L (mm) Stop (mm)

1.0 x 40	3	52-610-03	St	1
1.0 x 40	4	52-610-04	St	1
1.0 x 40	5	52-610-05	St	1
1.0 x 40	8	52-610-08	St	1

für/for/para/pour/per 2.1 mm SonicPins Rx

Ø x L (mm) Stop (mm)

1.6 x 40	3	52-616-03	St	1
1.6 x 40	4	52-616-04	St	1
1.6 x 40	5	52-616-05	St	1
1.6 x 40	10	52-616-10	St	1



Stufenbohrer, Step drill, Broca bidiametral, Foret étagé, Fresa a livelli

für/for/para/pour/per 2.1 mm SonicPins Rx

Ø x L (mm) Stop (mm)

1.6 x 70	verstellbar /adjustable/ ajustable / réglable/ regolabile	52-516-52	St	1	ohne Verstellhülse / w/o adjusting sleeve / sin casquillo de ajuste / sans écrou moleté / senza manicotto di regolazione
		52-516-60	1	Verstellhülse / adjusting sleeve / casquillo de ajuste écrou moleté / manicotto di regolazione	



Dental-Ansatz/Dental attachment/Sujeción dental/Embout dentaire/Attacco dentale
Kernlochbohrer, Core hole drill, Broca para taladro de roscar, Foret pour avant-trou, Fresa nucleo

für/for/para/pour/per 1.6 mm SonicPins Rx

Ø x L (mm) Stop (mm)

1.0 x 20	5	52-509-05	St	1
1.0 x 20	6	52-509-06	St	1

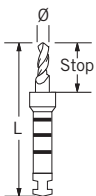

Gleitlochbohrer, Gliding hole drill, Broca para taladro deslizante, Foret pour trou de glissement, Fresa a scorrimento

für/for/para/pour/per 1.6 mm SonicPins Rx

Kernlochbohrer, Core hole drill, Broca para taladro de roscar, Foret pour avant-trou, Fresa nucleo

für/for/para/pour/per 2.1 mm SonicPins Rx

Ø x L (mm) Stop (mm)

1.6 x 20	5	52-515-05	St	1
1.6 x 20	6	52-515-06	St	1
1.6 x 20	10	52-515-10	St	1
1.6 x 20	35	52-515-20	St	1

Gleitlochbohrer, Gliding hole drill, Broca para taladro deslizante, Foret pour trou de glissement, Fresa a scorrimento

für/for/para/pour/per 2.1 mm SonicPins Rx

Ø x L (mm) Stop (mm)

2.1 x 24	12	52-522-10	St	1
----------	----	-----------	----	---

Bestell- und Set-Empfehlungen

Order and set recommendations

Recomendaciones de pedido y de sets

Recommandations pour les commandes et les sets

Consigli relativi all'ordinazione e alla composizione

Membran / Mesh / Biegeschablone	Membrane/mesh/ bending template	Membrana/mesh/ plantilla maleable	Membrane/ mesh/ Gabarit de pliage	Membrana/Mesh/ Modello piegaplacche
Kategorie	Category	Categoría	Catégorie	Categoria
52-301-28 Resorb-x®-Membran 25 x 25 mm, t = 0,1 mm	Resorb x® membrane, 25 x 25 mm, t = 0.1 mm	Membrana Resorb x®, 25 x 25 mm, t = 0,1 mm	Membrane Resorb x® 25 x 25 mm, t = 0,1 mm	Membrana Resorb x® 25 x 25 mm, t = 0,1 mm
52-303-25 Resorb-x®-Mesh 25 x 25 mm, t = 0,3 mm perforiert	Resorb x® mesh, 25 x 25 mm, t = 0.3 mm, perforated	Mesh Resorb x®, 25 x 25 mm, t = 0,3 mm, perforada	Mesh Resorb x® 25 x 25 mm, t = 0,3 mm, perforé	Mesh Resorb x® da 25 x 25 mm, t = 0,3 mm, perforato
52-303-28 Resorb-x®-Membran 25 x 25 mm, t = 0,3 mm nicht perforiert	Resorb x® membrane, 25 x 25 mm, t = 0.3 mm, non-perforated	Membrana Resorb x®, 25 x 25 mm, t = 0,3 mm, no perforada	Membrane Resorb x® 25 x 25 mm, t = 0,3 mm non perforée	Membrana Resorb x® da 25 x 25 mm, t = 0,3 mm, non perforato
52-303-50 Resorb-x®-Mesh 50 x 50 mm, t = 0,3 mm perforiert	Resorb x® mesh, 50 x 50 mm, t = 0.3 mm, perforated	Mesh Resorb x®, 50 x 50 mm, t = 0,3 mm, perforada	Mesh Resorb x® 50 x 50 mm, t = 0,3 mm, perforé	Mesh Resorb x® da 50 x 50 mm, t = 0,3 mm, perforato
52-303-52 Resorb-x®-Mesh 50 x 50 mm, t = 0,3 mm nicht perforiert	Resorb x® mesh, 50 x 50 mm, t = 0.3 mm, non-perforated	Mesh Resorb x®, 50 x 50 mm, t = 0,3 mm, no perforada	Mesh Resorb x® 50 x 50 mm, t = 0,3 mm, non perforé	Mesh Resorb x® da 50 x 50 mm, t = 0,3 mm, non perforato
52-313-25 Biegeschablone 25 x 25 mm	Bending template, 25 x 25 mm	Plantilla maleable, 25 x 25 mm	Gabarit de pliage 25 x 25 mm	Modello piegaplacche da 25 x 25 mm
52-313-50 Biegeschablone 50 x 50 mm	Bending template, 50 x 50 mm	Plantilla maleable, 50 x 50 mm	Gabarit de pliage 50 x 50 mm	Modello piegaplacche da 50 x 50 mm



52-301-28

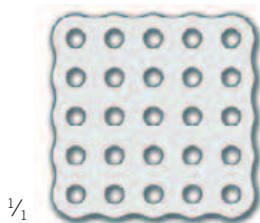

52-303-25

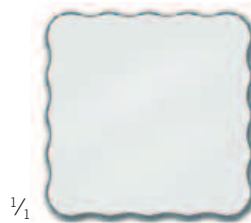

52-303-28

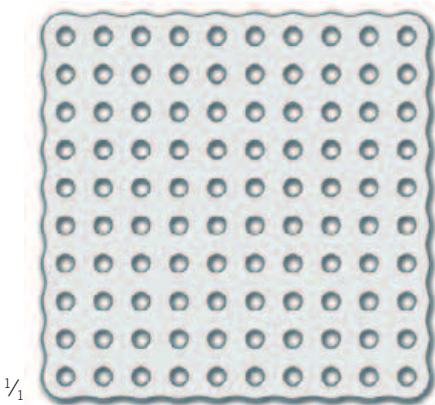

52-303-50

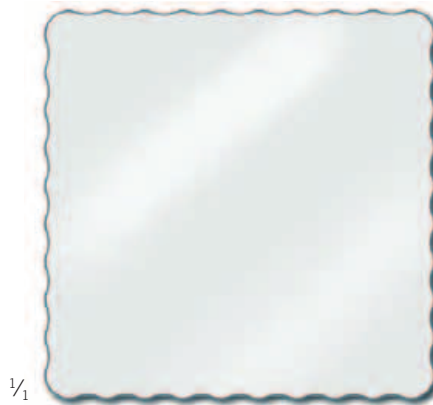

52-303-52

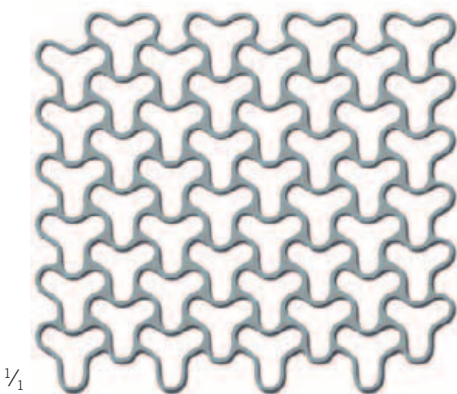

52-313-50

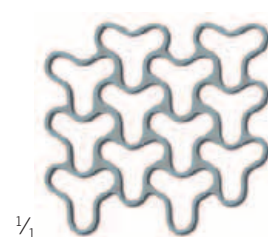

52-313-25

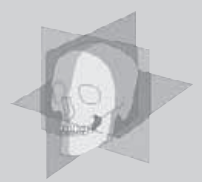

SonicPins Rx

Ø x L (mm)	Cat. No.	Cat. No.
1.6 x 4 mm	52-516-24	52-516-54
1.6 x 5 mm	52-516-25	52-516-55
1.6 x 6 mm	52-516-26	52-516-56
1.6 x 7 mm	52-516-27	52-516-57
2.1 x 4 mm	52-521-24	52-521-54
2.1 x 5 mm	52-521-25	52-521-55
2.1 x 7 mm	52-521-27	52-521-57
2.1 x 9 mm	52-521-29	52-521-59
2.1 x 11 mm	52-521-31	
2.1 x 13 mm	52-521-33	
2.1 x 15 mm	52-521-35	
2.1 x 17 mm	52-521-37	



Weitere Broschüren und Informationsmaterialien
 Additional product brochures and information materials
 Folletos y materiales informativos adicionales
 Brochures supplémentaires et matériels d'information
 Ulteriori opuscoli e materiale informativo



SonicWeld Rx®



SonicWeld Rx®
Guided Bone Regeneration



SonicWeld Rx®
CD-ROM

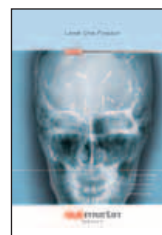

Level One catalog

39

Tamponstopfer

Gauze Packers
Taponeadores
Porte-tampon
Tamponatori



Tamponstopfer

Gauze Packers

Taponeadores

Porte-tampon

Tamponatori

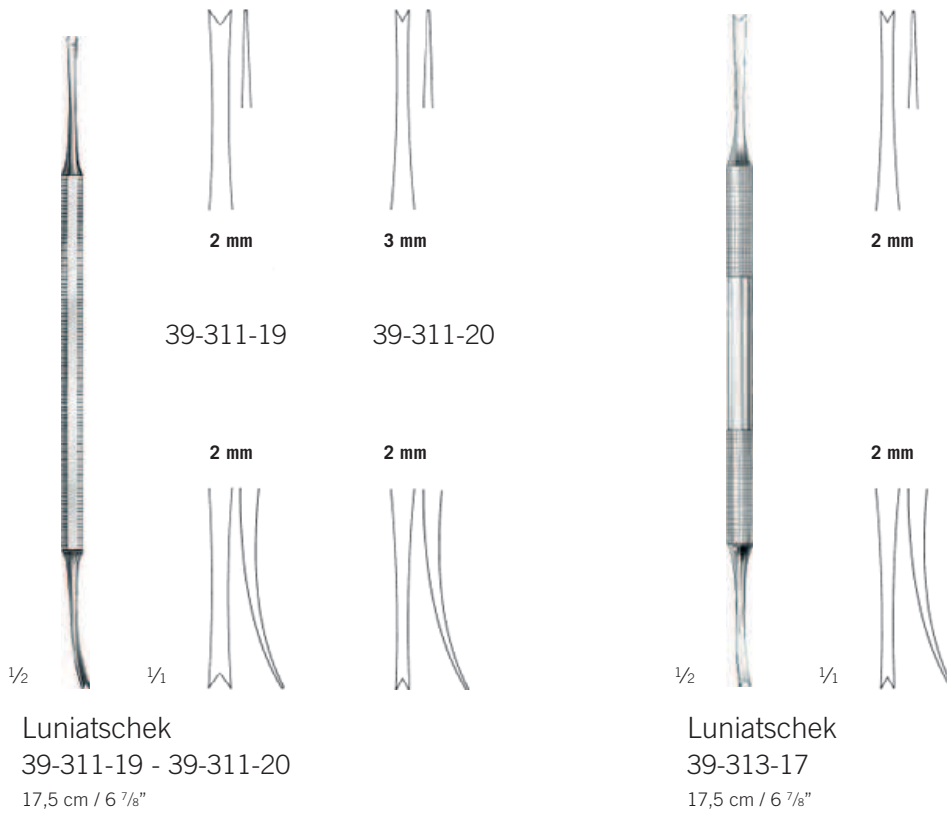

40-41

Zahnzangen

Extracting forceps

Fórceps dentales

Daviers

Pinze per estrazione

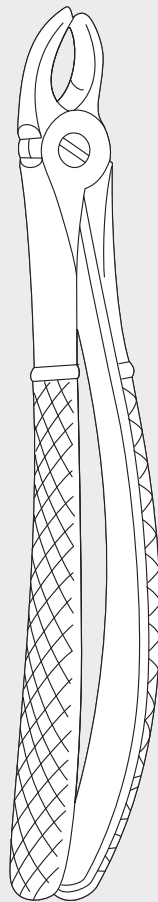

Zahnzangen, Englische Form, Oberkiefer

Extracting forceps, English pattern, upper jaw

Fórceps dentales, forma inglesa, mandibula superior

Daviers, forme anglaise, mandibule supérieure

Pinze per estrazione, forma inglese, mascella superiore



40-001-00 Fig. 1
Schneide- und Eckzähne
Incisors and cuspids
Incisivos y caninos
Incisives et canines
Denti incisivi e denti canini

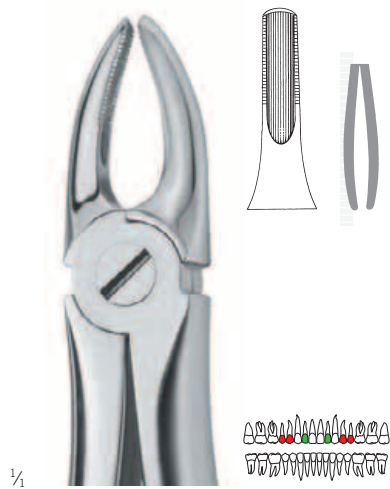

40-002-00 Fig. 2
Seitliche Schneidezähne und Prämolaren
Incisors and bicuspid
Incisivos y premolares
Incisives et prémolaires
Denti incisivi laterali e denti premolari



40-007-00 Fig. 7
Prämolaren
Bicuspid
Premolares
Prémolaires
Denti premolari

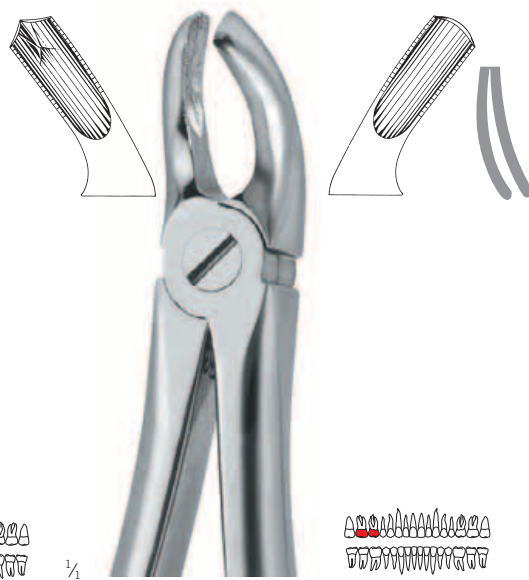

40-017-00 Fig. 17
Molaren, rechts
Molars, right
Molares, derecho
Molaires, droit
Denti molari, destra

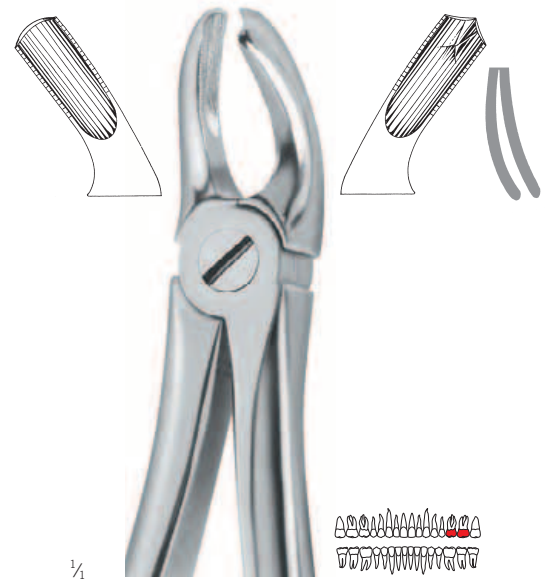

40-018-00 Fig. 18
Molaren, links
Molars, left
Molares, izquierdo
Molaires, gauche
Denti molari, sinistra

Zahnzangen, Englische Form, Oberkiefer

Extracting forceps, English pattern, upper jaw
 Fórceps dentales, forma inglesa, mandibula superior
 Daviers, forme anglaise, mandibule supérieure
 Pinze per estrazione, forma inglese, mascella superiore

Zahnzangen

Extracting forceps
 Fórceps dentales
 Daviers
 Pinze per estrazione



40-41

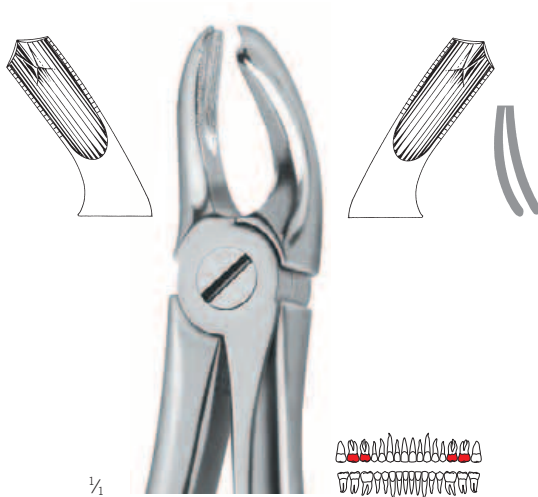

40-018-01 Fig. 18 A

Molaren
 Molars
 Molares
 Molaires
 Denti molari

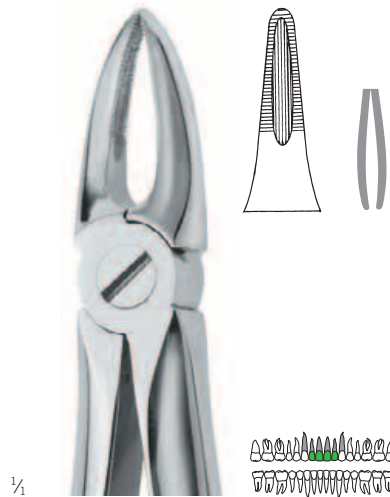

40-029-00 Fig. 29

Wurzeln und Schneidezähne
 Roots and incisors
 Raíces y incisivos
 Racines et incisives
 Radici e denti incisivi

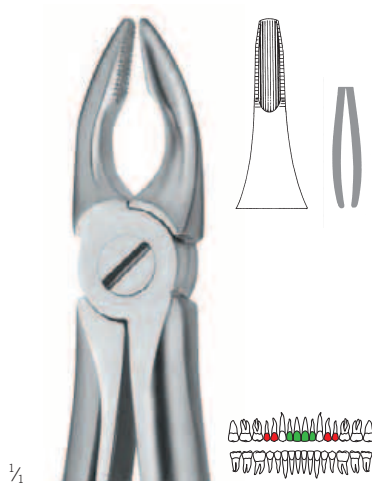

40-034-00 Fig. 34 N

Schneidezähne und Prämolaren,
 tiefgreifend

Incisors and bicuspidis,
 deep-gripping

Incisivos y premolares,
 a gran calado

Incisives et prémolaires,
 à attaque profonde

Denti incisivi e denti premolari,
 profondo

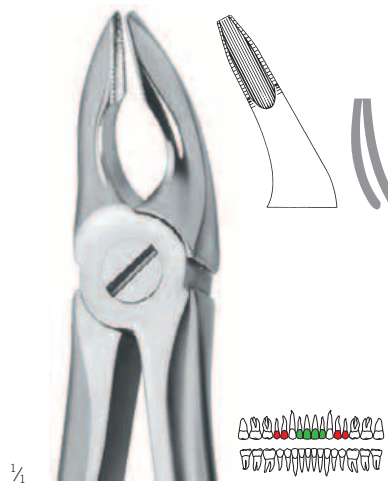

40-035-00 Fig. 35 N

Schneidezähne und Prämolaren,
 tiefgreifend

Incisors and bicuspidis,
 deep-gripping

Incisivos y premolares,
 a gran calado

Incisives et prémolaires,
 à attaque profonde

Denti incisivi e denti premolari,
 profondo

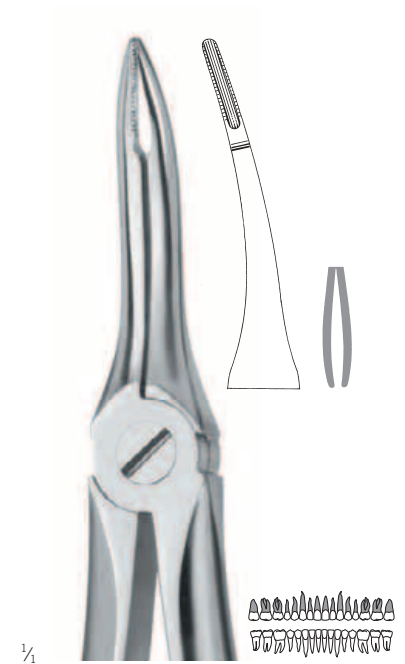

40-049-00 Fig. 49

Wurzeln, sehr fein
 Roots, very fine
 Raíces, muy delgadas
 Racines, très fines
 Radici, molto fini

Zahnzangen, Englische Form, Oberkiefer

Extracting forceps, English pattern, upper jaw

Fórceps dentales, forma inglesa, mandibula superior

Daviers, forme anglaise, mandibule supérieure

Pinze per estrazione, forma inglese, mascella superiore

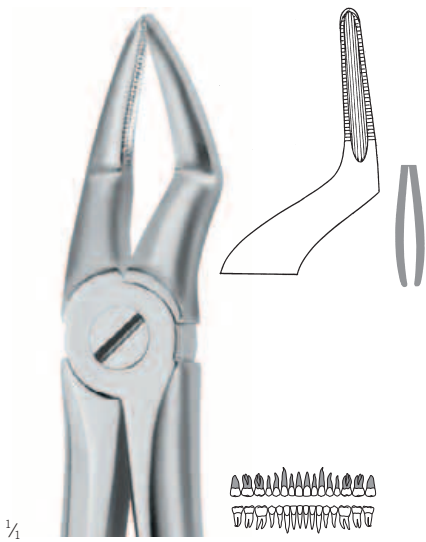

40-051-00 Fig. 51

Wurzeln
Roots
Raíces
Racines
Radici

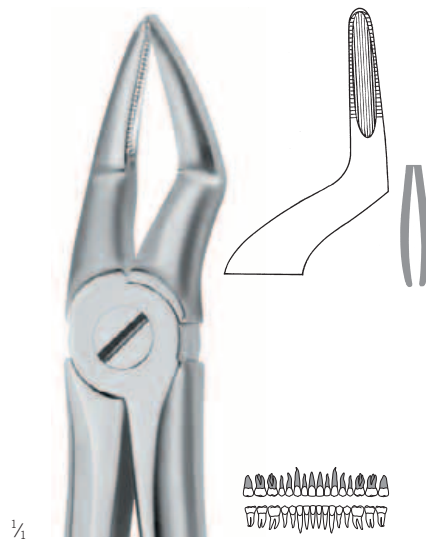

40-051-01 Fig. 51 A

Wurzeln
Roots
Raíces
Racines
Radici

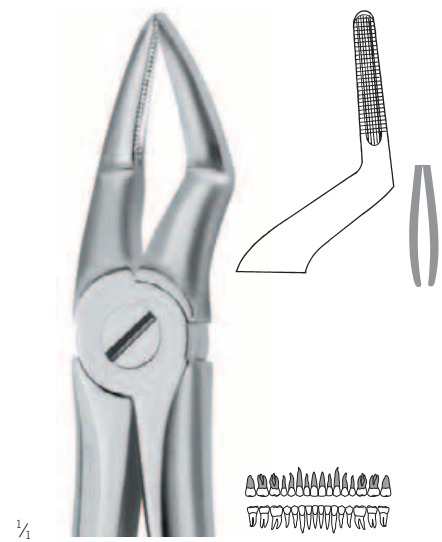

40-051-03 Fig. 51 C

Wurzeln
Roots
Raíces
Racines
Radici

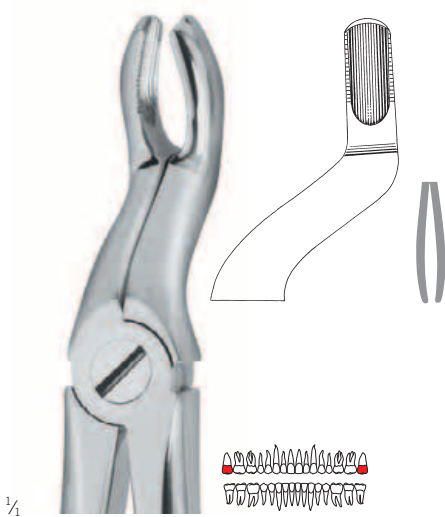

40-067-00 Fig. 67,

Weisheitszähne
Third molars
Terceros molares
Troisièmes molaires
Denti del giudizio

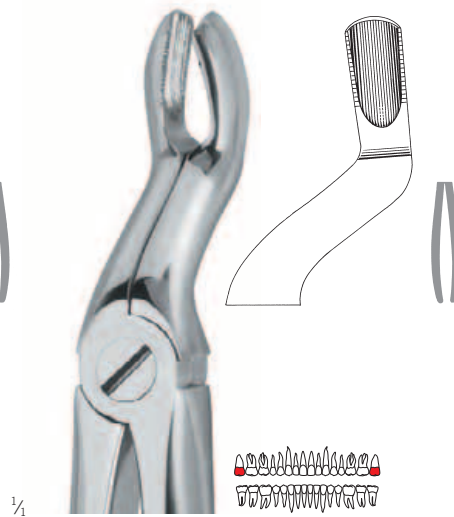

40-067-01 Fig. 67 A

Weisheitszähne
Third molars
Terceros molares
Troisièmes molaires
Denti del giudizio

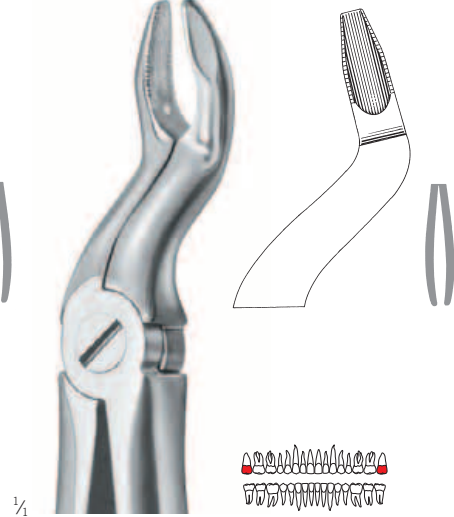

40-067-02 Fig. 67 N

Weisheitszähne, tiefgreifend
Third molars, deep-gripping
Terceros molares, a gran calado
Troisièmes molaires, à attaque profonde
Denti del giudizio, profondo

Zahnzangen, Englische Form, Oberkiefer

Extracting forceps, English pattern, upper jaw
 Fórceps dentales, forma inglesa, mandibula superior
 Daviers, forme anglaise, mandibule supérieure
 Pinze per estrazione, forma inglese, mascella superiore

Zahnzangen

Extracting forceps
 Fórceps dentales
 Daviers
 Pinze per estrazione



40-41

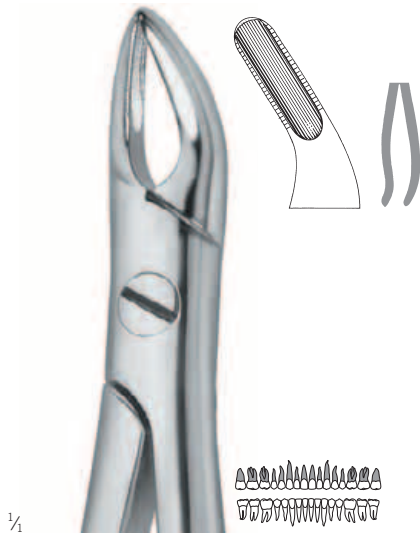

Lawrence-Read
 40-076-00 Fig. 76

Wurzeln
 Roots
 Raíces
 Racines
 Radici

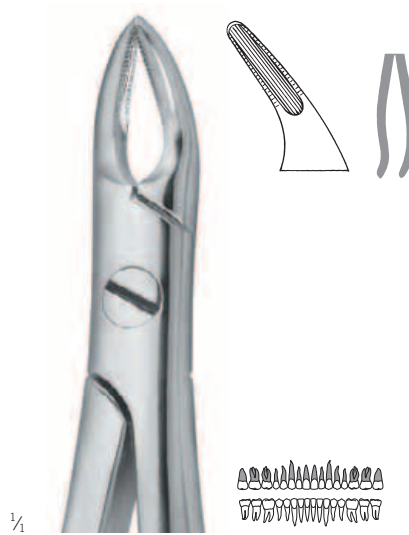

Lawrence-Read
 40-076-07 Fig. 76 N

Wurzeln
 Roots
 Raíces
 Racines
 Radici

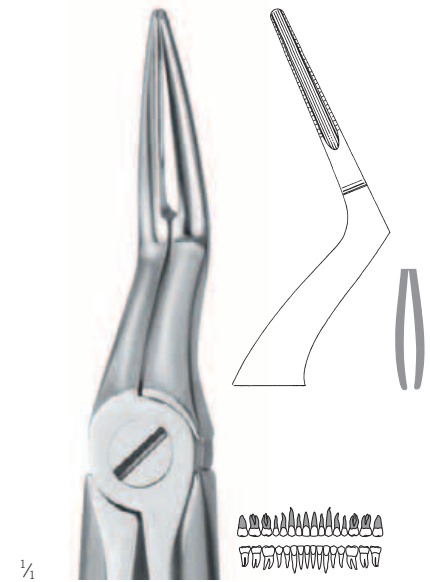

40-097-00 Fig. 97

Wurzeln, sehr fein
 Roots, very fine
 Raíces muy delgadas
 Racines très fines
 Radici, molto fini

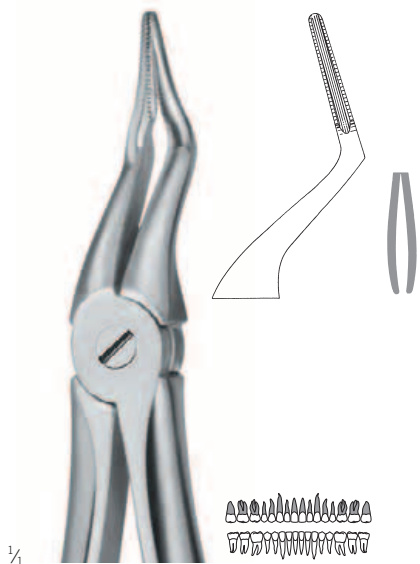

40-151-00 Fig. 151

Wurzeln, sehr fein
 Roots, very fine
 Raíces muy delgadas
 Racines très fines
 Radici, molto fini

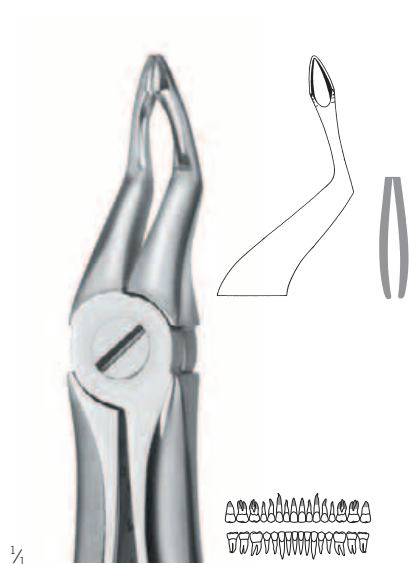

40-153-00 Fig. 153

Wurzelreste, tiefgreifend
 Root fragments, deep-gripping
 Fragmentos de raíces, a gran calado
 Fragments de racines, à attaque profonde
 Frammenti di radici, profondo

Zahnzangen, Englische Form, Unterkiefer

Extracting forceps, English pattern, lower jaw

Fórceps dentales, forma inglesa, mandibula inferior

Daviers, forme anglaise, mandibule inférieure

Pinze per estrazione, forma inglese, mascella inferiore



¼

40-004-00 Fig. 4

Schneide- und Eckzähne
Incisors and cuspids
Incisivos y caninos
Incisives et canines
Denti incisivi e denti canini



¼

40-013-00 Fig. 13

Prämolaren
Biscuspids
Premolares
Prémolaires
Denti premolari



¼

40-022-00 Fig. 22

Molaren
Molars
Molares
Molaires
Denti molari



¼

40-023-00 Fig. 23

Molaren, rechts
Molars, right
Molares, derecho
Molaires, droit
Denti molari, destra



¼

40-024-00 Fig. 24

Molaren, links
Molars, left
Molares, izquierdo
Molaires, gauche
Denti molari, sinistra

Zahnzangen, Englische Form, Unterkiefer

Extracting forceps, English pattern, lower jaw
 Fórceps dentales, forma inglesa, mandibula inferior
 Daviers, forme anglaise, mandibule inférieure
 Pinze per estrazione, forma inglese, mascella inferiore

Zahnzangen

Extracting forceps
 Fórceps dentales
 Daviers
 Pinze per estrazione



40-41



40-033-01 Fig. 33 A

Wurzeln, schlankes Maul
 Roots, slender jaw
 Raíces, boca delgada
 Racines, avec un bec très fin
 Radici, morso delicato



40-033-03 Fig. 33 C

Wurzeln, mit Haftprofil
 Roots, with anti-slip gripping surface
 Raíces, con superficie de adhesión
 Racines, à surface antiglissante
 Radici, con profilo adesivo

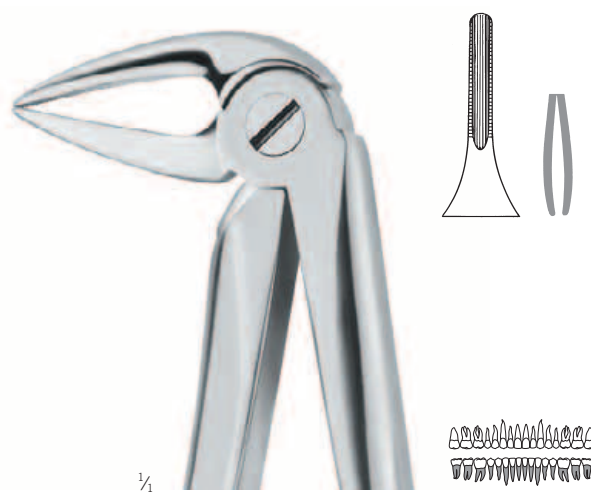

40-033-06 Fig. 33 M

Wurzeln, schlankes Maul
 Roots, slender jaw
 Raíces, boca delgada
 Racines, avec un bec très fin
 Radici, morso delicato

40-033-00 Fig. 33

Wurzeln
 Roots
 Raíces
 Racines
 Radici

Zahnzangen, Englische Form, Unterkiefer

Extracting forceps, English pattern, lower jaw

Fórceps dentales, forma inglesa, mandibula inferior

Daviers, forme anglaise, mandibule inférieure

Pinze per estrazione, forma inglese, mascella inferiore



40-036-00 Fig. 36

Prämolaren, tiefgreifend
Biscuspids, deep-gripping
Premolares, a gran calado
Prémolaires, à attaque profonde
Denti premolari, profondo

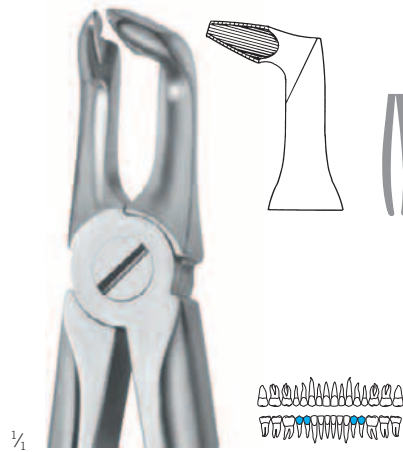

40-046-00 Fig. 46 N

Prämolaren, tiefgreifend
Biscuspids, deep-gripping
Premolares, a gran calado
Prémolaires, à attaque profonde
Denti premolari, profondo

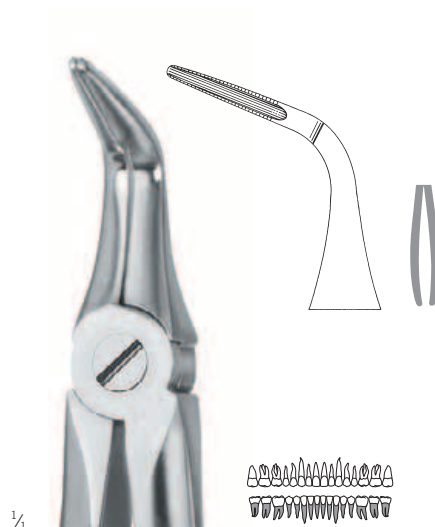

40-046-01 Fig. 46 L

Wurzeln, sehr fein
Roots, very fine
Raíces muy delgadas
Racines très fines
Radici, molto fini



40-046-02 Fig. 46 LX

Wurzeln, sehr fein
Roots, very fine
Raíces muy delgadas
Racines très fines
Radici, molto fini

Zahnzangen, Englische Form, Unterkiefer

Extracting forceps, English pattern, lower jaw
 Fórceps dentales, forma inglesa, mandibula inferior
 Daviers, forme anglaise, mandibule inférieure
 Pinze per estrazione, forma inglese, mascella inferiore

Zahnzangen

Extracting forceps
 Fórceps dentales
 Daviers
 Pinze per estrazione



40-41



40-073-00 Fig. 73

Molaren
 Molars
 Molares
 Molaires
 Denti molari



40-074-00 Fig. 74

Schneidezähne und Wurzeln
 Incisors and roots
 Incisivos y raíces
 Incisives et racines
 Denti incisivi e radici



40-074-06 Fig. 74 N

Schneidezähne und Wurzeln
 Incisors and roots
 Incisivos y raíces
 Incisives et racines
 Denti incisivi e radici



40-074-07 Fig. 74 XN

Schneidezähne und Wurzeln, schlankes Maul
 Incisors and roots, slender jaw
 Incisivos y raíces, boca delgada
 Incisives et racines, avec un bec très fin
 Denti incisivi e radici, morso delicato



40-075-00 Fig. 75

Eckzähne und Prämolaren
 Cuspids and bicuspid
 Caninos y premolares
 Canines et prémolaires
 Denti canini e denti premolari

Zahnzangen, Englische Form, Unterkiefer

Extracting forceps, English pattern, lower jaw

Fórceps dentales, forma inglesa, mandíbula inferior

Daviers, forme anglaise, mandibule inférieure

Pinze per estrazione, forma inglese, mascella inferiore



40-079-00 Fig. 79

Weisheitszähne
Third molars
Terceros molares
Troisièmes molaires
Denti del giudizio



40-079-01 Fig. 79 A

Weisheitszähne
Third molars
Terceros molares
Troisièmes molaires
Denti del giudizio

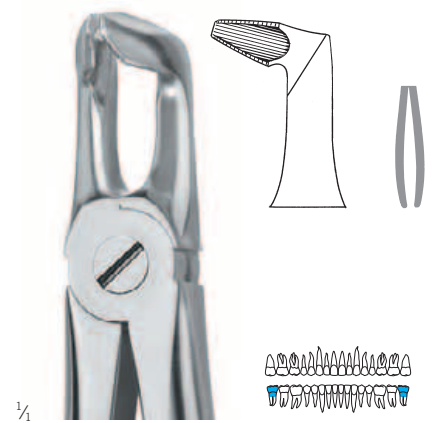

40-079-02 Fig. 79 N

Weisheitszähne, tiefgreifend
Third molars, deep-gripping
Terceros molares, a gran calado
Troisièmes molaires, à attaque profonde
Denti del giudizio, profondo

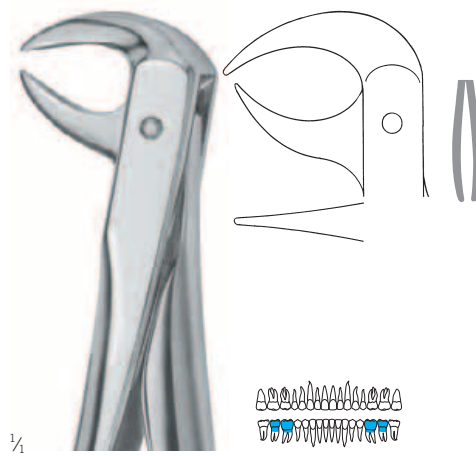

40-086-01 Fig. 86 A

Molaren mit kariösen oder abgebrochenen Kronen
Molars with carious or broken caps
Molares con coronas rotas o cariadas
Molaires avec couronnes cariées ou cassées
Denti molari con corone cariate o spezzate



40-086-02 Fig. 86 B

Molaren mit kariösen oder abgebrochenen Kronen
Molars with carious or broken caps
Molares con coronas rotas o cariadas
Molaires avec couronnes cariées ou cassées
Denti molari con corone cariate o spezzate

Zahnzangen, Englische Form, Unterkiefer

Extracting forceps, English pattern, lower jaw
 Fórceps dentales, forma inglesa, mandibula inferior
 Daviers, forme anglaise, mandibule inférieure
 Pinze per estrazione, forma inglese, mascella inferiore

Zahnzangen

Extracting forceps
 Fórceps dentales
 Daviers
 Pinze per estrazione



40-41



40-086-03 Fig. 86 C

Molaren mit kariösen oder abgebrochenen Kronen
 Molars with carious or broken caps
 Molares con coronas cariadas o rotas
 Molaires avec couronnes cariées ou cassées
 Denti molari con corone cariate o spezzate



40-133-00 Fig. 133

Wurzeln, sehr fein
 Roots, very fine
 Raíces, muy delgadas
 Racines très fines
 Radici, molto fini

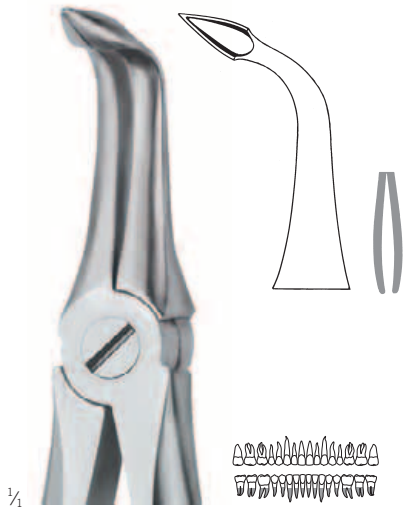

40-146-00 Fig. 146

Wurzelreste, tiefgreifend
 Root fragments, deep-gripping
 Fragmentos de raíces, a gran calado
 Fragments de racines, à attaque profonde
 Frammenti di radici, profondo



40-233-00 Fig. 233

Wurzeln, mit Parallelmaul
 Roots, with parallel beak
 Raíces, con pico paralelo
 Racines, avec un bec parallel
 Radici, morso parallelo

Zahnzangen Martin Fino, Oberkiefer

Extracting forceps Martin Fino, upper jaw

Férceps dentales Martin Fino, mandibula superior

Daviers Martin Fino, mandibule supérieure

Pinze per estrazione Martin Fino, mascella superiore

finoLine

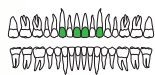
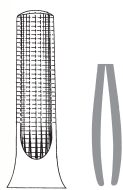

¼

40-301-00 Fig. 1

mittlere Schneide- und Eckzähne
Incisors and cuspids
Incisivos y caninos
Incisives et canines
Denti incisivi medi e denti canini

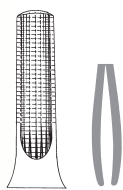

¼

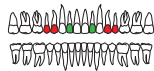
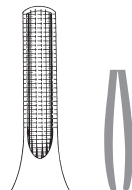
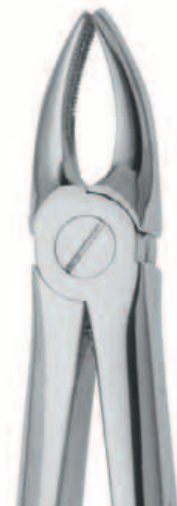

40-302-00 Fig. 2

seitliche Schneidezähne und Prämolaren
Incisors and bicuspid
Incisivos y premolares
Incisives et prémolaires
Denti incisivi laterali e denti premolari

¼

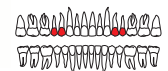
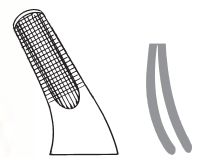

40-307-00 Fig. 7

Prämolaren
Bicuspid
Premolares
Prémolaires
Denti premolari

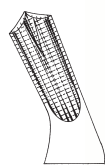

¼

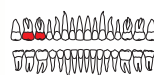
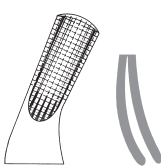

40-317-00 Fig. 17

Molaren, rechts
Molars, right
Molares, derecho
Molaires, droit
Denti molari, destra

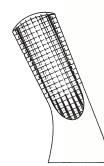

¼

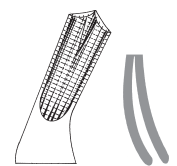

40-318-00 Fig. 18

Molaren, links
Molars, left
Molares, izquierdo
Molaires, gauche
Denti molari, sinistra

Zahnzangen Martin Fino, Oberkiefer

Extracting forceps Martin Fino, upper jaw
 Fórceps dentales Martin Fino, mandíbula superior
 Daviers Martin Fino, mandibule supérieure
 Pinze per estrazione Martin Fino, mascella superiore

Zahnzangen

Extracting forceps
 Fórceps dentales
 Daviers
 Pinze per estrazione



finoLine

40-41



40-330-00 Fig. 30
 Schneidezähne und Wurzeln
 Incisors and roots
 Incisivos y raíces
 Incisives et racines
 Denti incisivi e radici

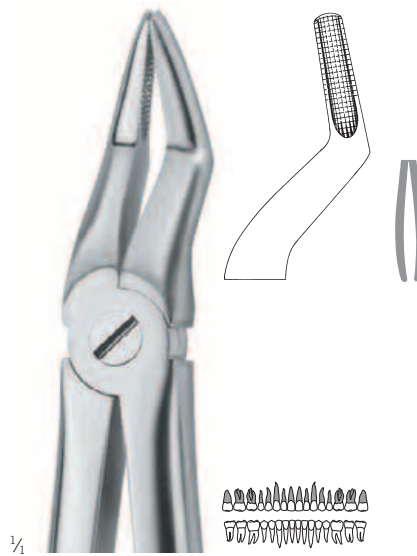

40-351-00 Fig. 51
 Wurzeln
 Roots
 Raíces
 Racines
 Radici

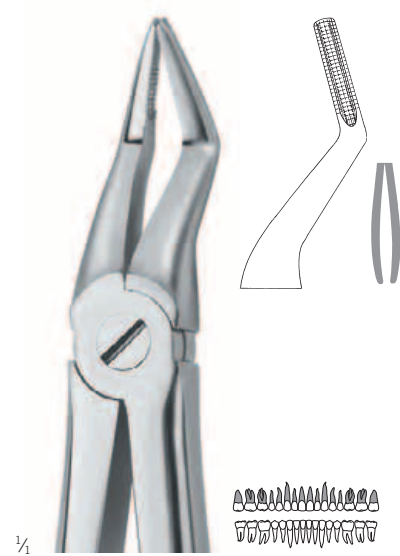

40-351-01 Fig. 51 A
 Wurzeln, sehr schlankes Maul
 Roots, very fine beak
 Raíces, con pico muy delgado
 Racines, avec un bec très fin
 Radici, morso molto delicato

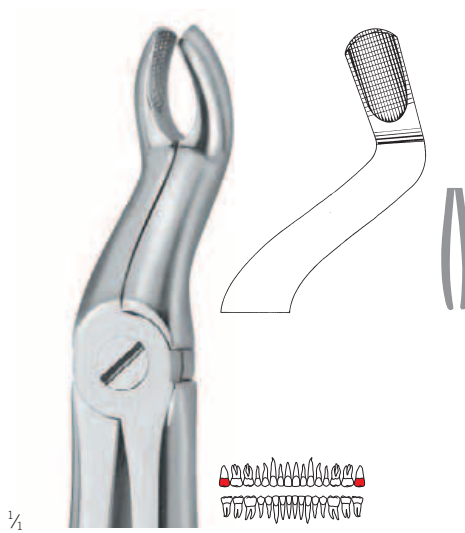

40-367-01 Fig. 67 A
 Weisheitszähne
 Third molars
 Terceros molares
 Troisième molaires
 Denti del giudizio

Zahnzangen Martin Fino, Unterkiefer

Extracting forceps Martin Fino, lower jaw

Fórceps dentales Martin Fino, mandíbula inferior

Daviers Martin Fino, mandibule inférieure

Pinze per estrazione Martin Fino, mascella inferiore

finoLine



40-313-00 Fig. 13

Prämolaren
Biscuspids
Premolares
Prémolaires
Denti premolari

40-322-00 Fig. 22

Molaren
Molars
Molares
Molaires
Denti molari

40-333-00 Fig. 33

Wurzeln
Roots
Raíces
Racines
Radici

Zahnzangen Martin Fino, Unterkiefer

Extracting forceps Martin Fino, lower jaw
 Fórceps dentales Martin Fino, mandíbula inferior
 Daviers Martin Fino, mandibule inférieure
 Pinze per estrazione Martin Fino, mascella inferiore

Zahnzangen

Extracting forceps
 Fórceps dentales
 Daviers
 Pinze per estrazione



finoLine

40-41



40-373-00 Fig. 73

Molaren
 Molars
 Molares
 Molaires
 Denti molari



40-374-00 Fig. 74

Schneidezähne und Wurzeln
 Incisors and roots
 Incisivos y raíces
 Incisives et racines
 Denti incisivi e radici



40-374-01 Fig. 74 N

Schneidezähne und Wurzeln, schlankes Maul
 Incisors and roots, with fine beak
 Incisivos y raíces, con pico delgado
 Incisives et racines, avec un bec très fin
 Denti incisivi e radici, morso delicato



40-379-00 Fig. 79

Weisheitszähne
 Third molars
 Terceros molares
 Troisième molaires
 Denti del giudizio

Kinderzahnzangen, Englische Form, Oberkiefer

Extracting forceps for children, English pattern, upper jaw

Fórceps dentales para niños, forma inglesa, mandíbula superior

Daviers pour enfants, forme anglaise, mandibule supérieure

Pinze per estrazione per bambini, forma inglese, mascella superiore



40-630-09 Fig. 30 S

Wurzeln und Schneidezähne

Incisors and roots

Incisivos y raíces

Incisives et racines

Radici e denti incisivi

40-637-00 Fig. 37

Schneide- und Eckzähne

Incisors and cuspids

Incisivos y caninos

Incisives et canines

Denti incisivi e denti canini

Kinderzahnzangen, Englische Form, Oberkiefer

Extracting forceps for children, English pattern, upper jaw
 Fórceps dentales para niños, forma inglesa, mandíbula superior
 Daviers pour enfants, forme anglaise, mandibule supérieure
 Pinze per estrazione per bambini, forma inglese, mascella superiore

Zahnzangen

Extracting forceps
 Fórceps dentales
 Daviers
 Pinze per estrazione



40-41



40-639-00 Fig. 39

Molaren
 Molars
 Molares
 Molaires
 Denti molari

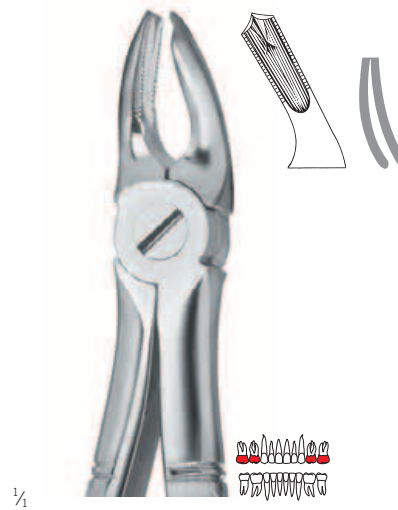

40-639-01 Fig. 39 A

Molaren
 Molars
 Molares
 Molaires
 Denti molari

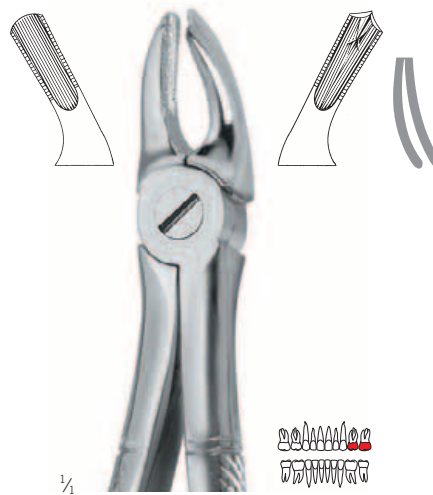

40-639-05 Fig. 39 L

Molaren, links
 Molars, left
 Molares, izquierdo
 Molaires, gauche
 Denti molari, sinistra

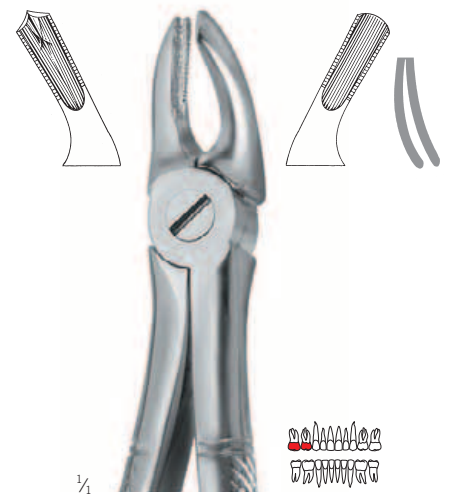

40-639-08 Fig. 39 R

Molaren, rechts
 Molars, right
 Molares, derecho
 Molaires, droit
 Denti molari, destra

Kinderzahnzangen, Englische Form, Oberkiefer

Extracting forceps for children, English pattern, upper jaw

Fórceps dentales para niños, forma inglesa, mandíbula superior

Daviers pour enfants, forme anglaise, mandibule supérieure

Pinze per estrazione per bambini, forma inglese, mascella superiore

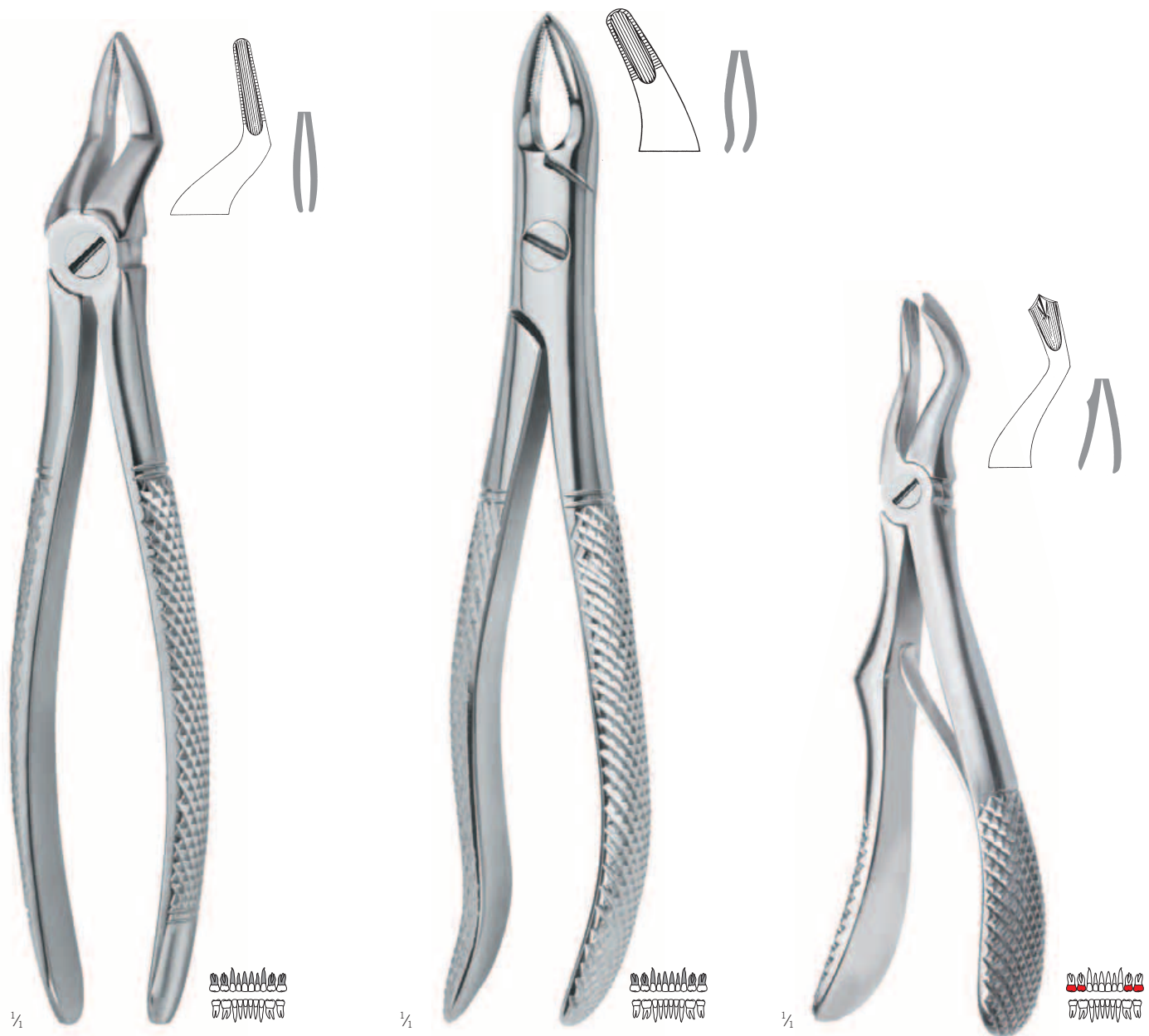

40-651-09 Fig. 51 S

Wurzeln
Roots
Raíces
Racines
Radici

Lawrence-Read
40-676-09 Fig. 76 S

Wurzeln
Roots
Raíces
Racines
Radici

Klein
40-703-00 Fig. 3

Molaren
Molars
Molares
Molaires
Denti molari

Kinderzahnzangen, Englische Form, Oberkiefer

Extracting forceps for children, English pattern, upper jaw
 Fórceps dentales para niños, forma inglesa, mandíbula superior
 Daviers pour enfants, forme anglaise, mandibule supérieure
 Pinze per estrazione per bambini, forma inglese, mascella superiore

Zahnzangen

Extracting forceps
 Fórceps dentales
 Daviers
 Pinze per estrazione

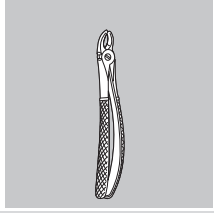

40-41



¼
 Klein
 40-737-00 Fig. 137
 Schneide- und Eckzähne
 Incisors and cuspids
 Incisivos y caninos
 Incisives et canines
 Denti incisivi e denti canini



¼
 Klein
 40-739-00 Fig. 139
 Prämolaren
 Biscuspids
 Premolares
 Prémolaires
 Denti premolari



¼
 Klein
 40-751-09 Fig. 51 S
 Wurzeln
 Roots
 Raíces
 Racines
 Radici

Kinderzahnzangen, Englische Form, Unterkiefer

Extracting forceps for children, English pattern, lower jaw
 Fórceps dentales para niños, forma inglesa, mandíbula inferior
 Daviers pour enfants, forme anglaise, mandibule inférieure
 Pinze per estrazione per bambini, forma inglese, mascella inferiore



40-613-09 Fig. 13 S

Prämolaren
 Bicuspid
 Premolares
 Prémolaires
 Denti premolari



40-622-09 Fig. 22 S

Molaren
 Molars
 Molares
 Molaires
 Denti molari



40-633-09 Fig. 33 S

Wurzeln
 Roots
 Raíces
 Racines
 Radici



40-638-00 Fig. 38

Schneide- und Eckzähne
 Incisors and cuspids
 Incisivos y caninos
 Incisives et canines
 Denti incisivi e denti canini

Kinderzahnzangen, Englische Form, Unterkiefer

Extracting forceps for children, English pattern, lower jaw
 Fórceps dentales para niños, forma inglesa, mandíbula inferior
 Daviers pour enfants, forme anglaise, mandibule inférieure
 Pinze per estrazione per bambini, forma inglese, mascella inferiore

Zahnzangen

Extracting forceps
 Fórceps dentales
 Daviers
 Pinze per estrazione

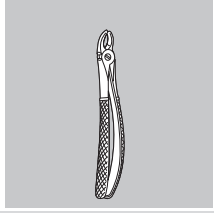

40-41



40-640-00 Fig. 40
 Molaren
 Molars
 Molares
 Molaires
 Denti molari



Klein
 40-705-00 Fig. 5
 Schneidezähne
 Incisors
 Incisivos
 Incisives
 Denti incisivi

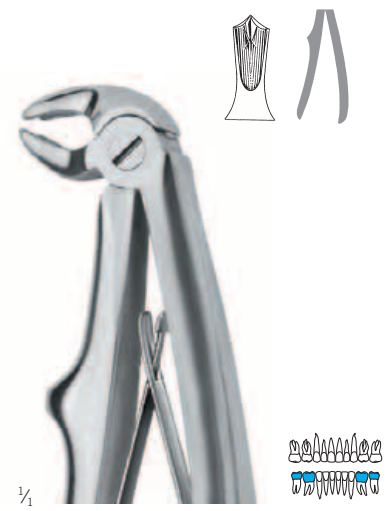

Klein
 40-706-00 Fig. 6
 Molaren
 Molars
 Molares
 Molaires
 Denti molari

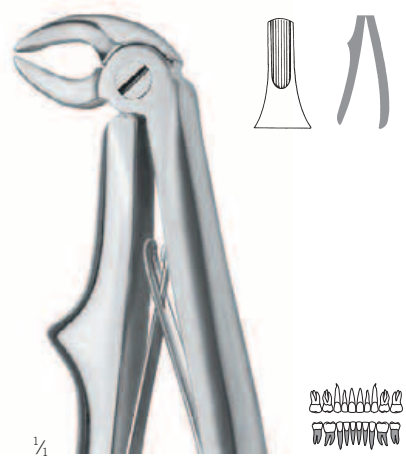

Klein
 40-707-00 Fig. 7
 Wurzeln
 Roots
 Raíces
 Racines
 Radici

Kinderzahnzangen, Amerikanische Form, Oberkiefer

Extracting forceps for children, American pattern, upper jaw

Fórceps dentales para niños, forma americana, mandíbula superior

Daviers pour enfants, forme américaine, mandibule supérieure

Pinze per estrazione per bambini, forma americana, mascella superiore



40-850-09 Fig. 150 SK
Zähne und Wurzeln, universal
Teeth and roots, universal
Dientes y raíces, universal
Dentes et racines, universel
Denti e radici, universale



40-817-09 Fig. 17 SK
Molaren
Molars
Molares
Molaires
Denti molari

Kinderzahnzangen, Amerikanische Form, Oberkiefer

Extracting forceps for children, American pattern, upper jaw
Fórceps dentales para niños, forma americana, mandíbula superior
Daviers pour enfants, forme américaine, mandibule supérieure
Pinze per estrazione per bambini, forma americana, mascella superiore

Zahnzangen

Extracting forceps
Fórceps dentales
Daviers
Pinze per estrazione



40-41



40-823-09 Fig. 23 SK

Molaren
Molars
Molares
Molaires
Denti molari



40-851-09 Fig. 151 SK

Zähne und Wurzeln, universal
Teeth and roots, universal
Dientes y raíces, universal
Dentes et racines, universel
Denti e radici, universale

Diamantierte Zahnzangen Martin Ergo, Oberkiefer

Extracting forceps Martin Ergo, diamond coated, upper jaw

Fórceps dentales Martin Ergo, mandibula superior

Daviers Martin Ergo, mandibule supérieure

Pinze per estrazione Martin Ergo, mascella superiore

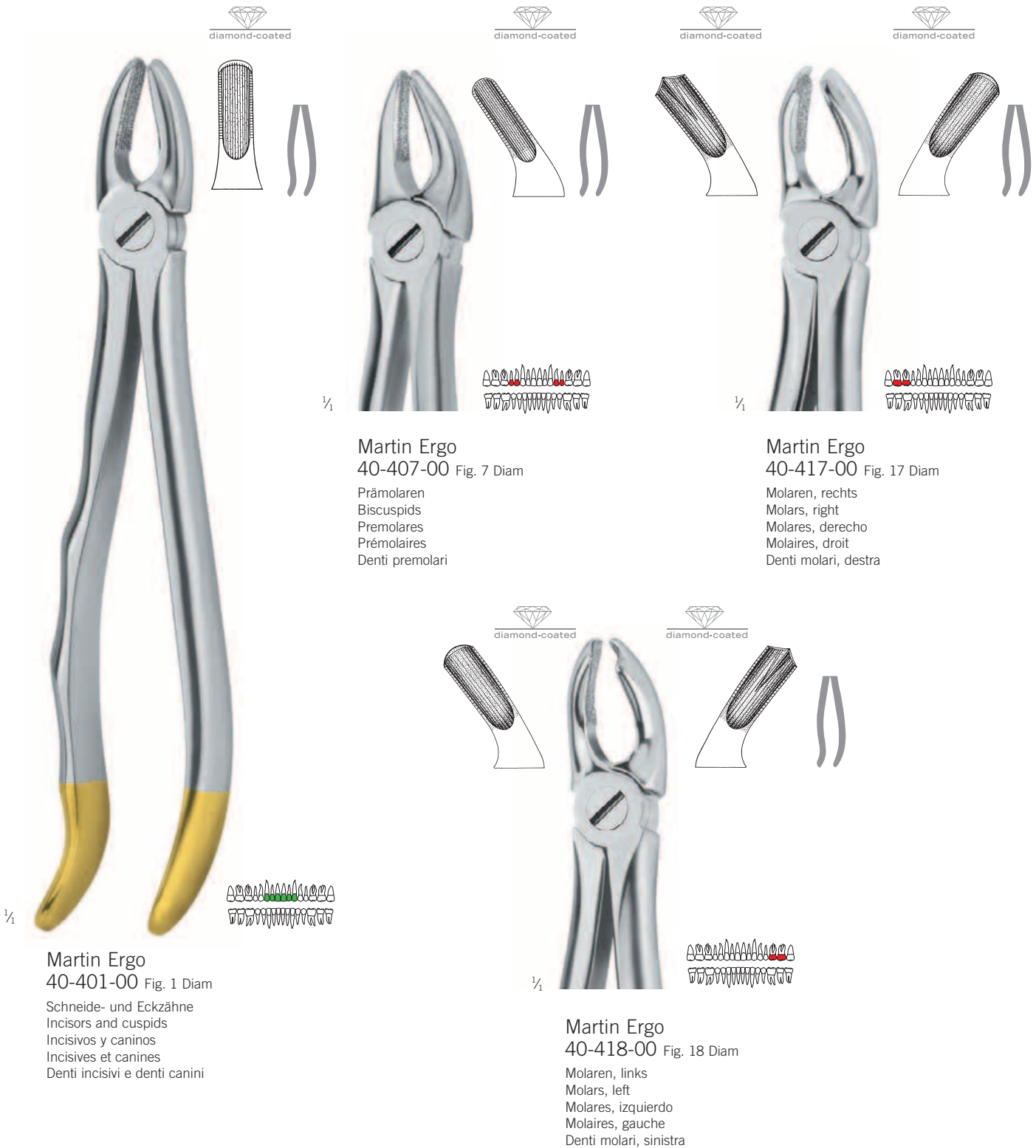

Martin Ergo
 40-407-00 Fig. 7 Diam
 Prämolaren
 Biscuspids
 Premolares
 Prémolaires
 Denti premolari

Martin Ergo
 40-417-00 Fig. 17 Diam
 Molaren, rechts
 Molars, right
 Molares, derecho
 Molaire, droit
 Denti molari, destra

Martin Ergo
 40-401-00 Fig. 1 Diam
 Schneide- und Eckzähne
 Incisors and cuspids
 Incisivos y caninos
 Incisives et canines
 Denti incisivi e denti canini

Martin Ergo
 40-418-00 Fig. 18 Diam
 Molaren, links
 Molars, left
 Molares, izquierdo
 Molaire, gauche
 Denti molari, sinistra

Diamantierte Zahnzangen Martin Ergo, Oberkiefer

Extracting forceps Martin Ergo, diamond coated, upper jaw

Fórceps dentales Martin Ergo, mandibula superior

Daviers Martin Ergo, mandibule supérieure

Pinze per estrazione Martin Ergo, mascella superiore

Zahnzangen

Extracting forceps

Fórceps dentales

Daviers

Pinze per estrazione



40-41

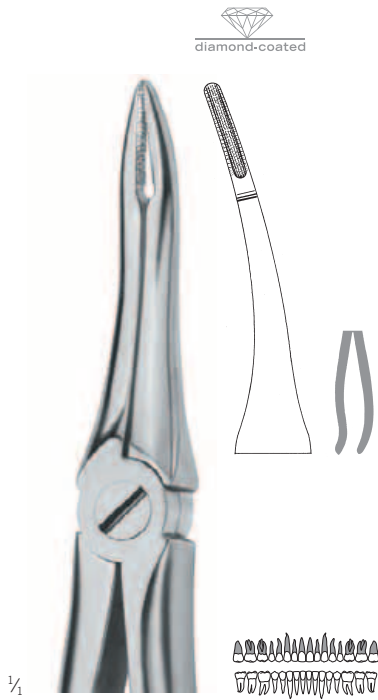

Martin Ergo
40-449-00 Fig. 49 Diam

Wurzeln, sehr fein
Roots, very fine
Raíces, muy delgadas
Racines très fines
Radici, molto fini

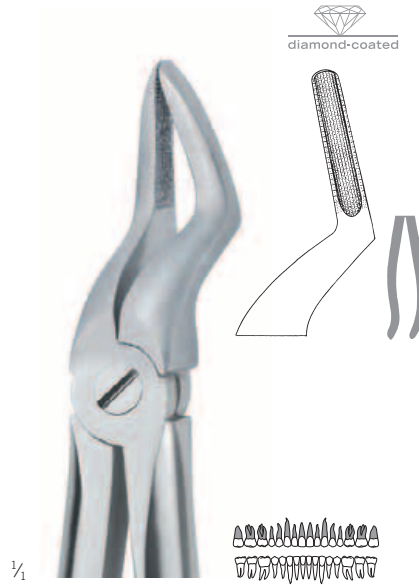

Martin Ergo
40-451-00 Fig. 51 Diam

Wurzeln
Roots
Raíces
Racines
Radici



Martin Ergo
40-451-01 Fig. 51 A Diam

Wurzeln, schlankes Maul
Roots, with fine beak
Raíces, con pico delgado
Racines, avec un bec très fin
Radici, morso delicato

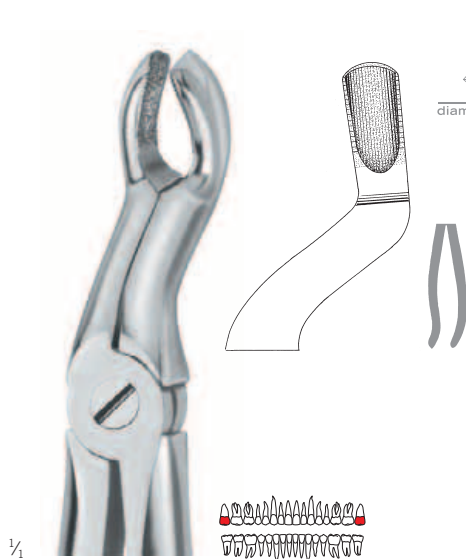

Martin Ergo
40-467-01 Fig. 67 A Diam

Weisheitszähne
Third molars
Terceros molares
Troisième molaires
Denti del giudizio

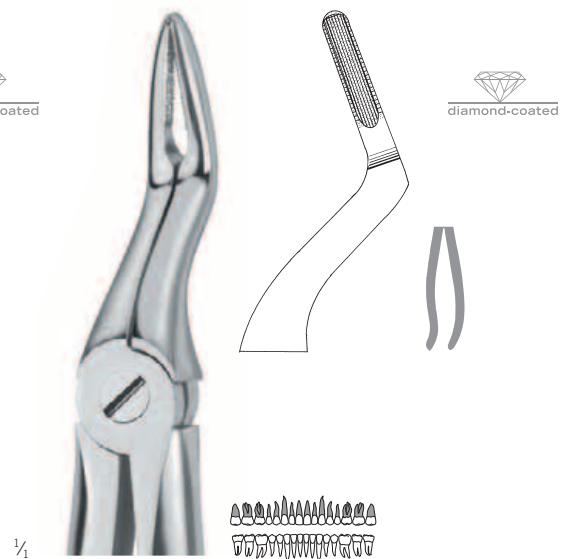

Martin Ergo
40-497-00 Fig. 97 Diam

Wurzeln, sehr fein
Roots, very fine
Raíces, muy delgadas
Racines très fines
Radici, molto fini

Diamantierte Zahnzangen Martin Ergo, Unterkiefer

Extracting forceps Martin Ergo, diamond coated, lower jaw

Fórceps dentales Martin Ergo, mandibula inferior

Daviers Martin Ergo, mandibule inférieure

Pinze per estrazione Martin Ergo, mascella inferiore

diamond-coated

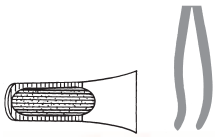

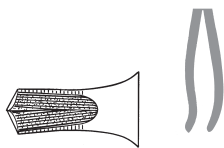

diamond-coated

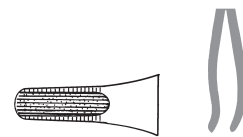

Martin Ergo
40-422-00 Fig. 22 Diam
Molaren
Molars
Molares
Molaires
Denti molari

diamond-coated



Martin Ergo
40-433-00 Fig. 33 Diam
Wurzeln
Roots
Raíces
Racines
Radici

Martin Ergo
40-413-00 Fig. 13 Diam
Schneidezähne und Prämolaren
Incisors and cuspids
Incisivos y premolares
Incisives et prémolaires
Denti incisivi e denti premolari

Diamantierte Zahnzangen Martin Ergo, Unterkiefer

Extracting forceps Martin Ergo, diamond coated, lower jaw

Fórceps dentales Martin Ergo, mandíbula inferior

Daviers Martin Ergo, mandibule inférieure

Pinze per estrazione Martin Ergo, mascella inferiore

Zahnzangen

Extracting forceps

Fórceps dentales

Daviers

Pinze per estrazione



40-41



Martin Ergo
40-446-00 Fig. 46 Diam

Wurzeln, sehr fein
Roots, very fine
Raíces, muy delgadas
Racines très fines
Radici, molto fini



Martin Ergo
40-474-00 Fig. 74 N Diam

Wurzeln
Roots
Raíces
Racines
Radici



Martin Ergo
40-479-00 Fig. 79 Diam

Weisheitszähne
Third molars
Terceros molares
Troisième molaires
Denti del giudizio

Zahnzangen, Amerikanische Form, Oberkiefer

Extracting forceps, American pattern, upper jaw
 Fôrceps dentales, forma americana, mandibula superior
 Daviers, forme américaine, mandibule supérieure
 Pinze per estrazione, forma americana, mascella superiore

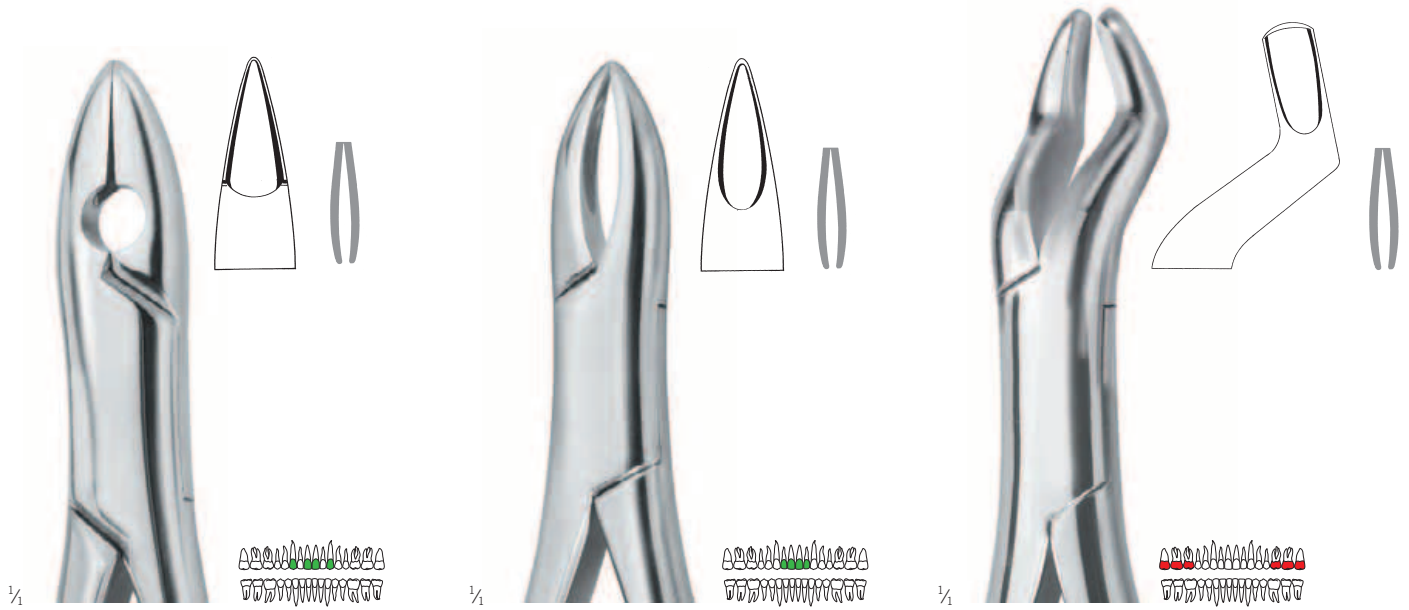

41-001-00 Fig. 1
 Schneide- und Eckzähne
 Incisors and cuspids
 Incisivos y premolares
 Incisives et prémolaires
 Denti incisivi e denti canini

Henahan
 41-001-01 Fig. 1 A
 Schneidezähne
 Incisors
 Incisivos
 Incisives
 Denti incisivi

41-010-09 Fig. 10 S
 Molaren und Weisheitszähne
 Molars and third molars
 Molares y terceros molares
 Molaïres et troisième molaïres
 Denti molari e denti del giudizio

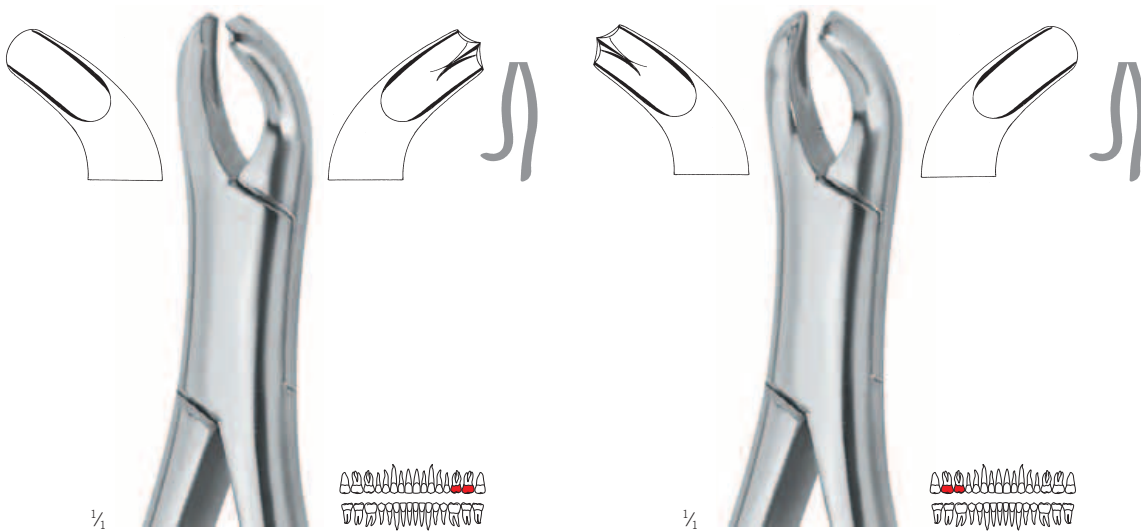

Harris
 41-018-05 Fig. 18 L
 Molaren, links
 Molars, left
 Molares, izquierdo
 Molaïres, gauche
 Denti molari, sinistra

Harris
 41-018-08 Fig. 18 R
 Molaren, rechts
 Molars, right
 Molares, derecho
 Molaïres, droit
 Denti molari, destra

Zahnzangen, Amerikanische Form, Oberkiefer

Extracting forceps, American pattern, upper jaw
 Fórceps dentales, forma americana, mandibula superior
 Daviers, forme américaine, mandibule supérieure
 Pinze per estrazione, forma americana, mascella superiore

Zahnzangen

Extracting forceps
 Fórceps dentales
 Daviers
 Pinze per estrazione



40-41

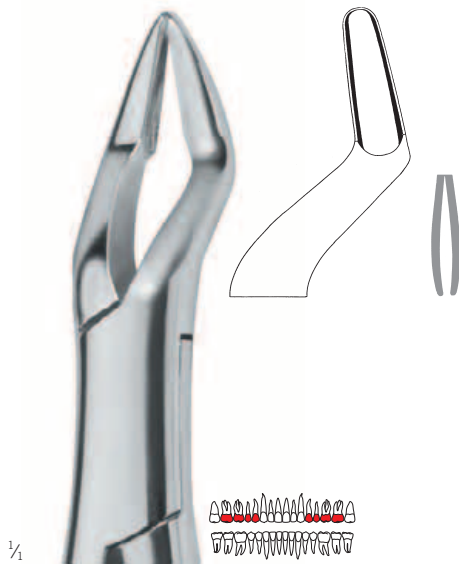

Parmly
 41-032-00 Fig. 32

Molaren und Prämolaren
 Molars and bicuspid
 Molares y premolares
 Molaire et prémolaires
 Denti molari e denti premolari

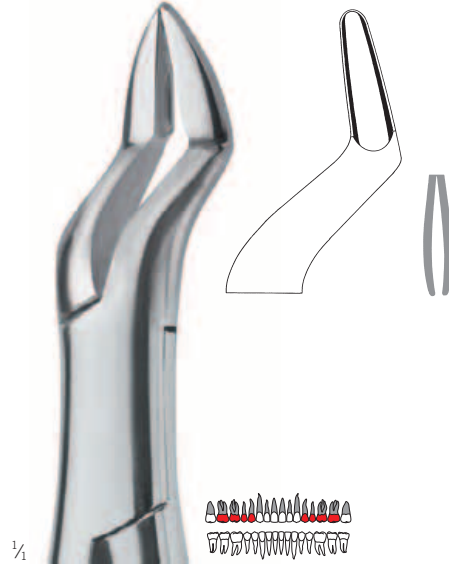

Parmly
 41-032-01 Fig. 32 A

Molaren, Prämolaren und Wurzeln
 Molars, bicuspid and roots
 Molares, premolares y raíces
 Molaire, prémolaires et racines
 Denti molari, denti premolari e radici



41-062-00 Fig. 62

Universal für Zähne und Wurzeln, auch für Kinder
 Teeth and roots, universal, also for children
 Dientes y raíces, universal, también para niños
 Dentes et racines, universel, aussi pour enfants
 Denti e radici, universale, anche per bambini

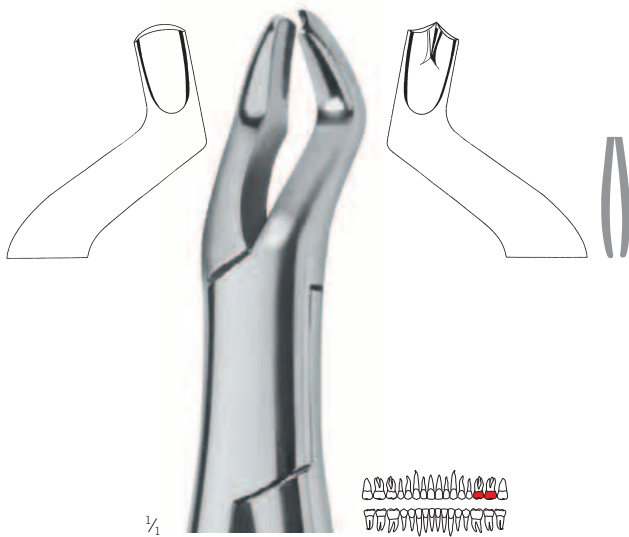

41-053-05 Fig. 53 L

Molaren, links
 Molars, left
 Molares, izquierdo
 Molaire, gauche
 Denti molari, sinistra

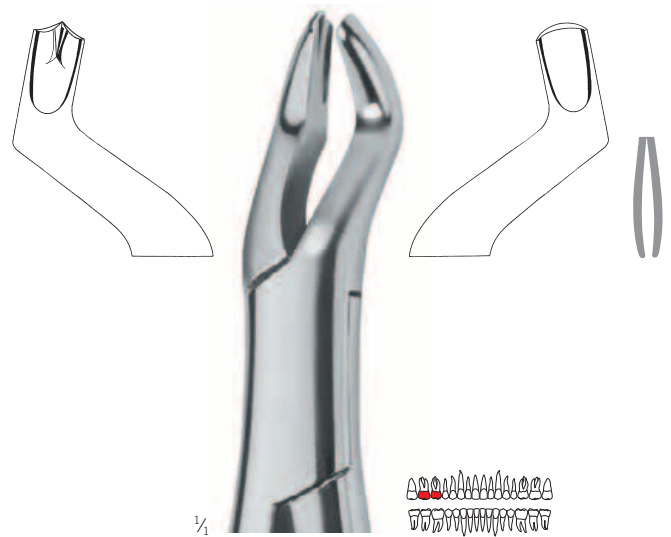

41-053-08 Fig. 53 R

Molaren, rechts
 Molars, right
 Molares, derecho
 Molaire, droit
 Denti molari, destra

Zahnzangen, Amerikanische Form, Oberkiefer

Extracting forceps, American pattern, upper jaw
 Fórceps dentales, forma americana, mandibula superior
 Daviers, forme américaine, mandibule supérieure
 Pinze per estrazione, forma americana, mascella superiore

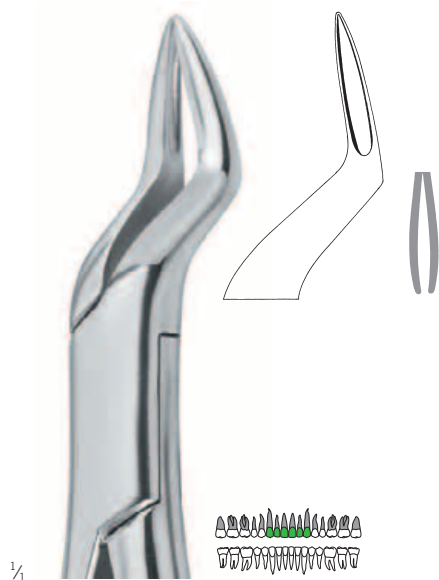

41-065-00 Fig. 65
 Schneidezähne und Wurzeln
 Incisors and roots
 Incisivos y raíces
 Incisives et racines
 Denti incisivi e radici



Tomes
 41-069-00 Fig. 69
 Wurzelsplitter und kleine Wurzeln (auch Unterkiefer)
 Root fragments and small roots (also for lower jaw)
 Fragmentos de raíces y raíces muy delgadas (también para mandibula inferior)
 Fragments de racines et racines très fines (aussi pour mandibule inférieure)
 Frammenti di radici e radici piccole (anche per mascella inferiore)

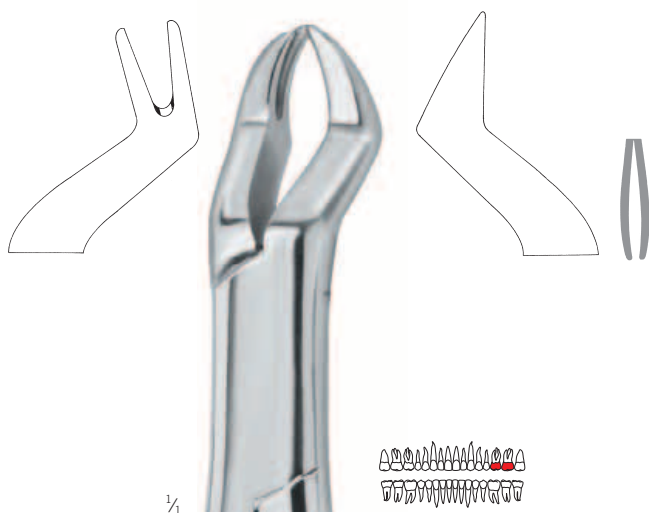

Nevius
 41-088-05 Fig. 88 L
 Molaren, links
 Molars, left
 Molares, izquierdo
 Molaires, gauche
 Denti molari, sinistra

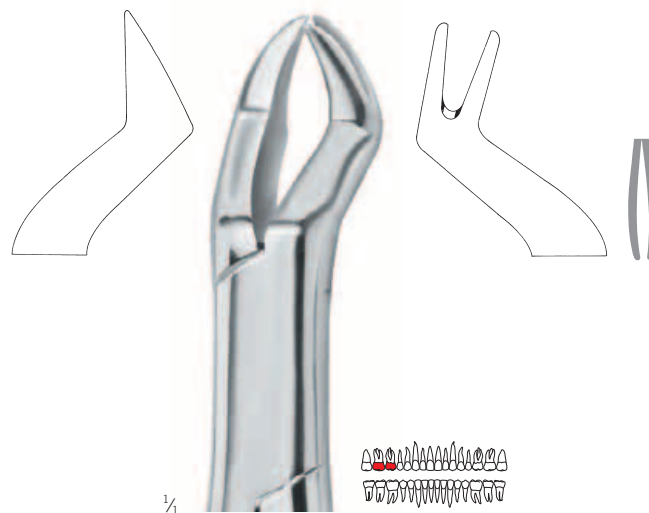

Nevius
 41-088-08 Fig. 88 R
 Molaren, rechts
 Molars, right
 Molares, derecho
 Molaires, droit
 Denti molari, destra

Zahnzangen, Amerikanische Form, Oberkiefer

Extracting forceps, American pattern, upper jaw

Fórceps dentales, forma americana, mandibula superior

Daviers, forme américaine, mandibule supérieure

Pinze per estrazione, forma americana, mascella superiore

Zahnzangen

Extracting forceps

Fórceps dentales

Daviers

Pinze per estrazione



40-41



Cryer

41-150-00 Fig. 150

Prämolaren, Schneidezähne und Wurzeln

Biscuspids, incisors and roots

Premolares, incisivos y raíces

Prémolaires, incisives et racines

Denti premolari, denti incisivi e radici



Cryer

41-150-01 Fig. 150

Prämolaren, Schneidezähne und Wurzeln

Biscuspids, incisors and roots

Premolares, incisivos y raíces

Prémolaires, incisives et racines

Denti premolari, denti incisivi e radici



41-150-02 Fig. 150 X

Prämolaren, Schneidezähne und Wurzeln

Biscuspids, incisors and roots

Premolares, incisivos y raíces

Prémolaires, incisives et racines

Denti premolari, denti incisivi e radici

Zahnzangen, Amerikanische Form, Oberkiefer

Extracting forceps, American pattern, upper jaw
 Fórceps dentales, forma americana, mandibula superior
 Daviers, forme américaine, mandibule supérieure
 Pinze per estrazione, forma americana, mascella superiore



41-150-08 Fig. 150 AS
 Prämolaren, Schneidezähne und Wurzeln
 Bicuspid, incisors and roots
 Premolares, incisivos y raíces
 Prémolaires, incisives et racines
 Denti premolari, denti incisivi e radici

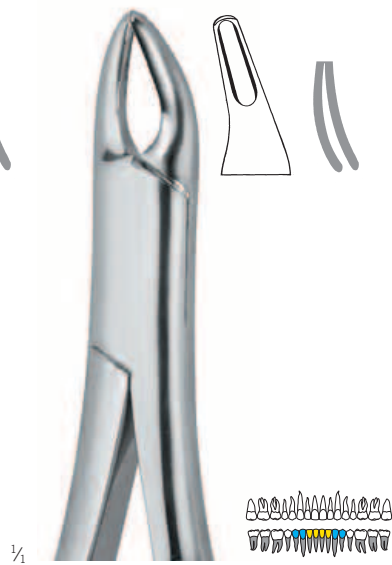

Cryer
 41-150-09 Fig. 150 S
 Prämolaren, Schneidezähne und Wurzeln
 Bicuspid, incisors and roots
 Premolares, incisivos y raíces
 Prémolaires, incisives et racines
 Denti premolari, denti incisivi e radici



Witzel
 41-501-00 Fig. 501
 Wurzelsplitterzange, universal
 Root fragments, universal
 Fragmentos de raíces, universal
 Fragments des racines, universal
 Frammenti di radici, universale

Zahnzangen, Amerikanische Form, Unterkiefer

Extracting forceps, American pattern, lower jaw
 Fórceps dentales, forma americana, mandibula inferior
 Daviers, forme américaine, mandibule inférieure
 Pinze per estrazione, forma americana, mascella inferiore

Zahnzangen

Extracting forceps
 Fórceps dentales
 Daviers
 Pinze per estrazione

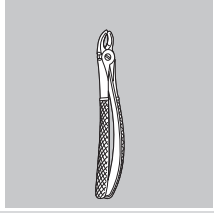

40-41



41-015-00 Fig. 15

Molaren
 Molars
 Molares
 Molaires
 Denti molari



41-016-00 Fig. 16

Molaren
 Molars
 Molares
 Molaires
 Denti molari

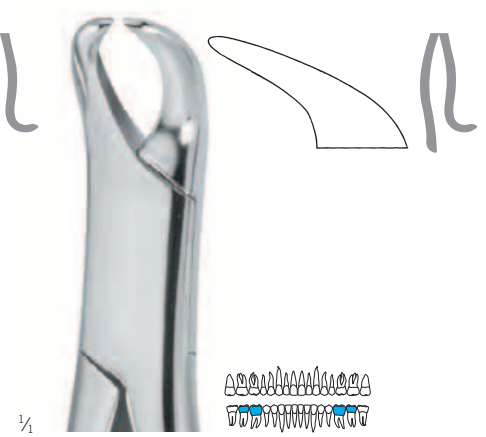

41-016-09 Fig. 16 S

Molaren, schlankes Maul
 Molars, slender jaw
 Molares, boca delgada
 Molaires, mors gracile
 Denti molari, morso delicato



41-017-00 Fig. 17

Molaren
 Molars
 Molares
 Molaires
 Denti molari



41-023-00 Fig. 23

Molaren
 Molars
 Molares
 Molaires
 Denti molari

Zahnzangen, Amerikanische Form, Unterkiefer

Extracting forceps, American pattern, lower jaw

Fórceps dentales, forma americana, mandibula inferior

Daviers, forme américaine, mandibule inférieure

Pinze per estrazione, forma americana, mascella inferiore



Cryer

41-151-00 Fig. 151

Prämolaren, Schneidezähne und Wurzeln
Biscuspids, incisors and roots
Premolares, incisivos y raíces
Prémolaires, incisives et racines
Denti premolari, denti incisivi e radici



Cryer

41-151-01 Fig. 151 A

Prämolaren, Schneidezähne und Wurzeln
Biscuspids, incisors and roots
Premolares, incisivos y raíces
Prémolaires, incisives et racines
Denti premolari, denti incisivi e radici



Cryer

41-151-02 Fig. 151 X

Prämolaren, Schneidezähne und Wurzeln
Biscuspids, incisors and roots
Premolares, incisivos y raíces
Prémolaires, incisives et racines
Denti premolari, denti incisivi e radici



41-151-08 Fig. 151 AS

Prämolaren, Schneidezähne und Wurzeln
Biscuspids, incisors and roots
Premolares, incisivos y raíces
Prémolaires, incisives et racines
Denti premolari, denti incisivi e radici



Cryer

41-151-09 Fig. 151 S

Zähne und Wurzeln, universal
Teeth and roots, universal
Dientes y raíces, universal
Dentes et racines, universel
Denti e radici, universale

Zahnzangen, Amerikanische Form, Unterkiefer

Extracting forceps, American pattern, lower jaw
 Fórceps dentales, forma americana, mandibula inferior
 Daviers, forme américaine, mandibule inférieure
 Pinze per estrazione, forma americana, mascella inferiore

Zahnzangen

Extracting forceps
 Fórceps dentales
 Daviers
 Pinze per estrazione

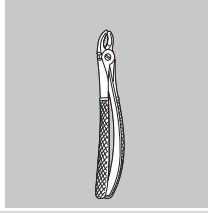

40-41



41-222-00 Fig. 222
 Weisheitszähne
 Third molars
 Terceros molares
 Troisième molaires
 Denti del giudizio



Witzel
 41-502-00 Fig. 502
 Wurzelsplitterzange, universal
 Root fragments, universal
 Fragmentos de raíces, universal
 Fragments des racines, universel
 Frammenti di radici, universale

Zahnzangen, tiefgreifend

Extracting forceps, deep-gripping

Fórceps dentales, a gran calado

Daviers, à attaque profonde

Pinze per estrazione, profondo



41-500-00

Schneide- und Eckzähne
Incisors and cuspids
Incisivos y caninos
Incisives et canines
Denti incisivi e denti canini

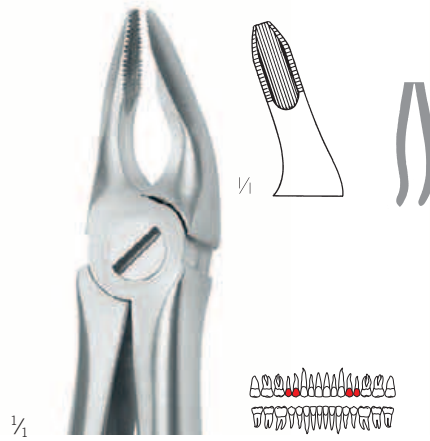

41-500-01

Prämolaren
Biscuspids
Premolares
Prémolaires
Denti premolari

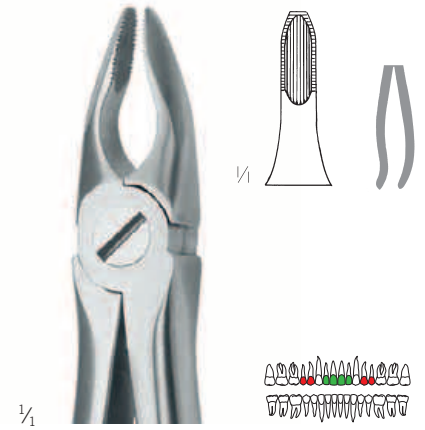

41-500-02

Schneidezähne und Prämolaren
Incisors and biscuspids
Incisivos y premolares
Incisives et prémolaires
Denti incisivi e denti premolari

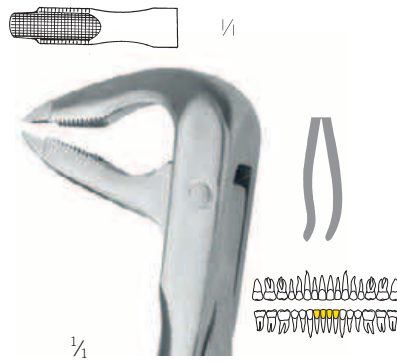

41-500-03

Schneidezähne
Incisors
Incisivos
Incisives
Denti incisivi

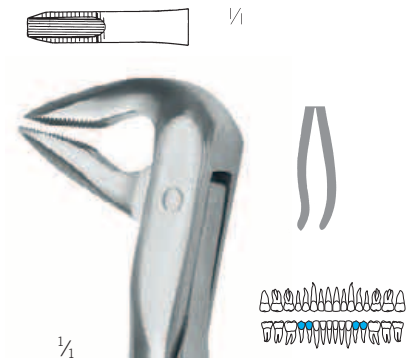

41-500-04

Molaren
Molars
Molares
Molaires
Denti molari

Zahnzangen, tiefgreifend

Extracting forceps, deep-gripping

Fórceps dentales, a gran calado

Daviers, à attaque profonde

Pinze per estrazione, profondo

Zahnzangen

Extracting forceps

Fórceps dentales

Daviers

Pinze per estrazione



40-41

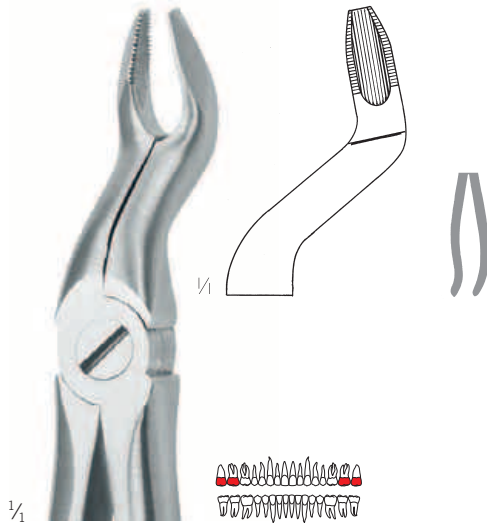

41-500-06

Molaren
Molars
Molares
Molaires
Denti molari

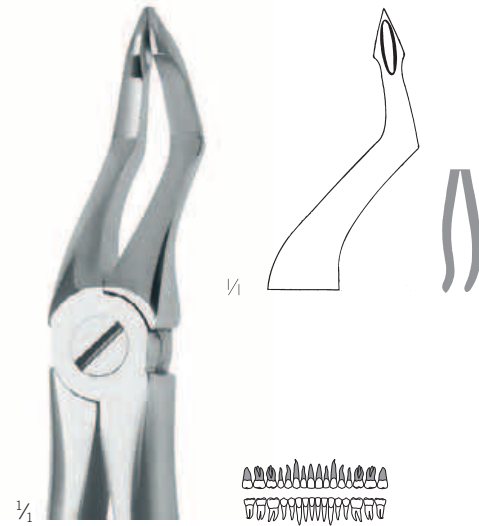

41-500-07

Wurzeln
Roots
Raíces
Racines
Radici

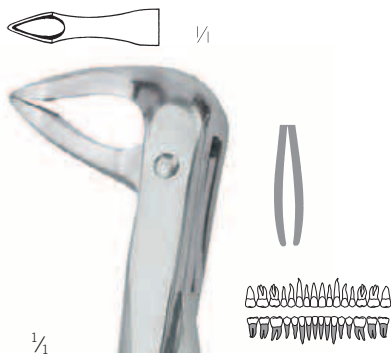

41-500-08

Wurzeln
Roots
Raíces
Racines
Radici



41-151-08

Prämolaren, Schneidezähne und Wurzeln
Bicuspid, incisors and roots
Premolares, incisivos y raíces
Prémolaires, incisives et racines
Denti premolari, denti incisivi e radici

42

Wurzelheber

Root elevators

Elevadores para raíces

Elévateurs de racines

Leve per radici

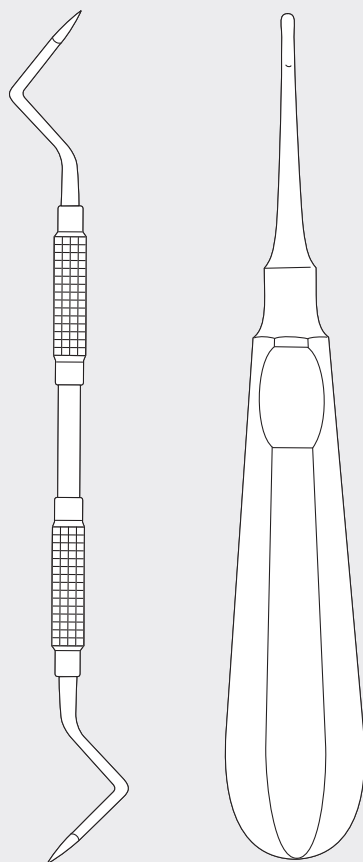

Wurzelheber

Root elevators

Elevadores para raíces

Élévateurs de racines

Leve per radici

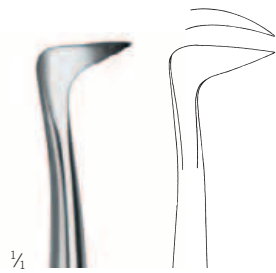

42-001-05 Fig. 1L



42-001-08 Fig. 1R

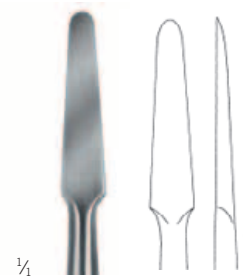

Seldin
42-002-00 Fig. 2

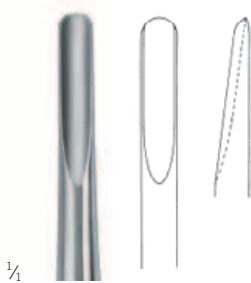

Seldin
42-003-00 Fig. 3



Cryer
42-003-01 Fig. 3 A



Seldin
42-004-05 Fig. 4 L



42-001-05 - 42-011-00



Seldin
42-004-08 Fig. 4 R



42-006-00 Fig. 6



42-008-00 Fig. 8



42-009-00 Fig. 9



Miller-Apexo
42-010-00 Fig. 10

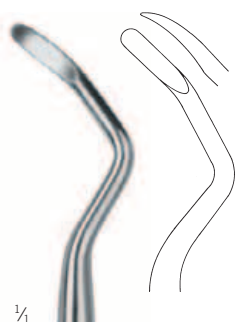

Miller-Apexo
42-011-00 Fig. 11

Wurzelheber

Root elevators
Elevadores para raíces
Élévateurs de racines
Leve per radici

Wurzelheber

Root elevators
Elevadores para raíces
Élévateurs de racines
Leve per radici

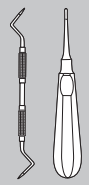

42-012-00 Fig. 12



Cryer
42-027-00 Fig. 27



Cryer
42-028-00 Fig. 28



Seldin
42-034-00 Fig. 34



Seldin
42-034-09 Fig. 34 S



Cryer
42-039-00 Fig. 39



1/2
42-012-0 - 42-200-03



Cryer
42-040-00 Fig. 40



Flohr
42-046-00 Fig. 46

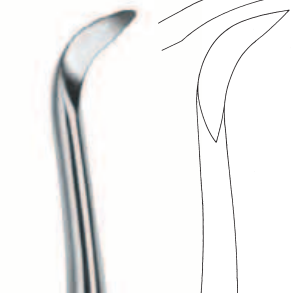

42-050-00 Fig. 50



42-051-00 Fig. 51



Lindo-Levian
42-200-01 Fig. 1

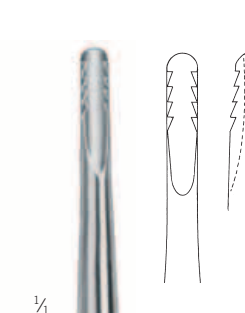

Lindo-Levian
42-200-03 Fig. 3

Wurzelheber

Root elevators

Elevadores para raíces

Elévateurs de racines

Leve per radici

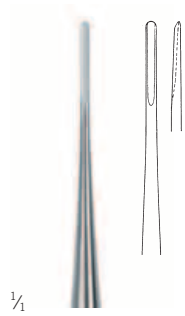

42-204-00 Fig. 1,3 S

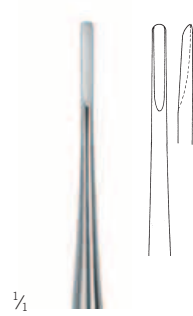

42-204-01 Fig. 1,8 S

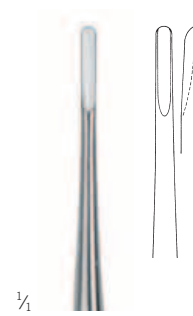

42-204-02 Fig. 2,3 S



42-204-00 - 42-205-01

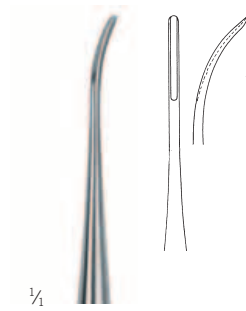

42-205-00 Fig. 1,3 C

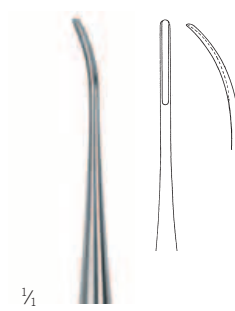

42-205-01 Fig. 1,3 RC

Luxatoren

Luxators
Luxadores
Luxateurs
Luxatori

Wurzelheber

Root elevators
Elevadores para raíces
Élévateurs de racines
Leve per radici

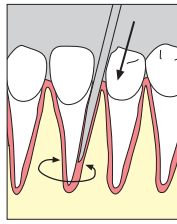
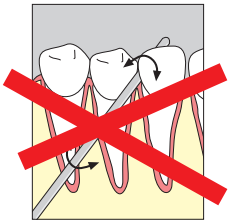
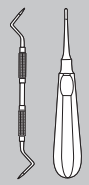

42

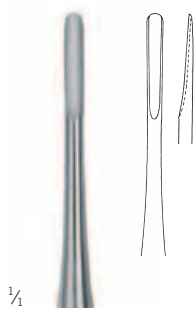

Bein
42-220-01 Fig. 1

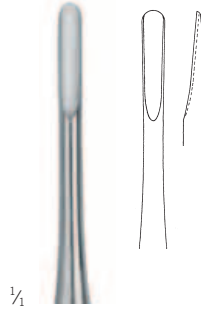

Bein
42-220-02 Fig. 2

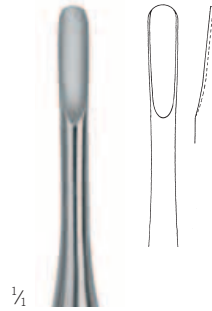

Bein
42-220-03 Fig. 3

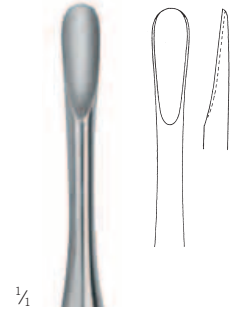

Bein
42-220-04 Fig. 4



1/2

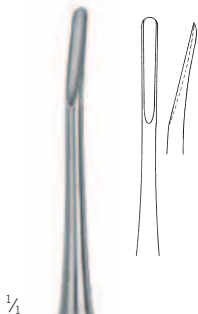

Bein
42-221-01 Fig. 1 A

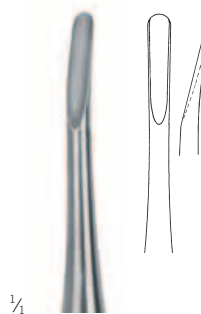

Bein
42-221-02 Fig. 2 A



Bein
42-221-03 Fig. 3 A

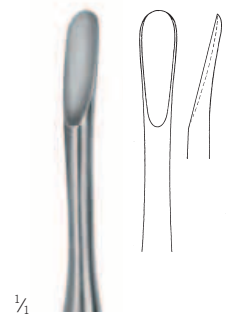

Bein
42-221-04 Fig. 4 A

42-220-01 -
42-221-04

Luxatoren

Luxators
Luxadores
Luxateurs
Luxatori

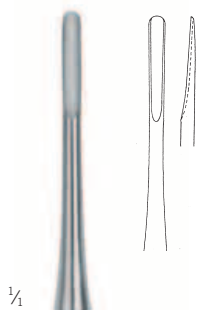
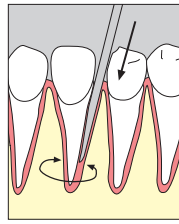
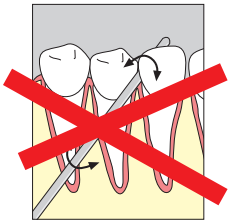

Apical
42-222-01 Fig. 1

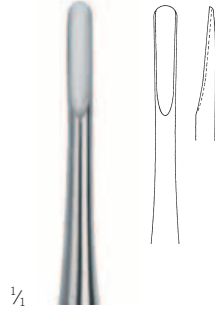

Apical
42-222-02 Fig. 2

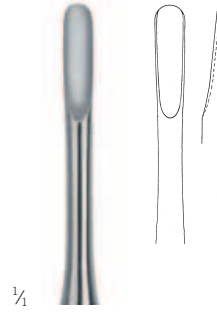

Apical
42-222-03 Fig. 3

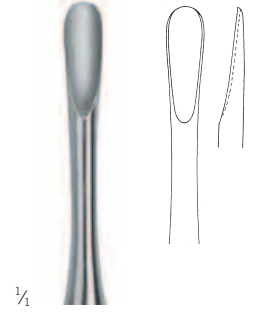

Apical
42-222-04 Fig. 4

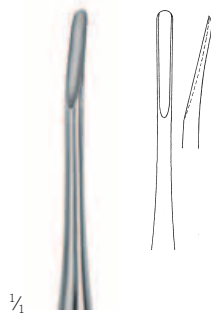

Apical
42-223-01 Fig. 1 A

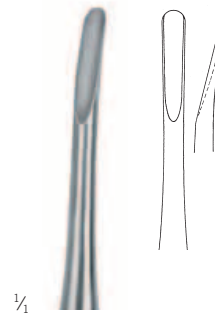

Apical
42-223-02 Fig. 2 A

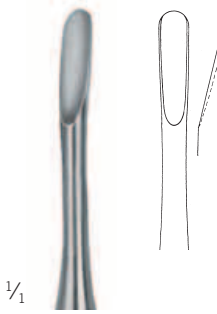

Apical
42-223-03 Fig. 3 A

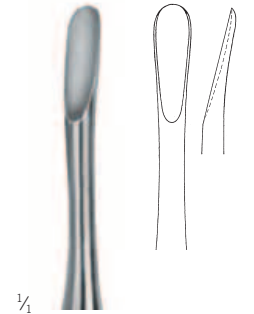

Apical
42-223-04 Fig. 4 A



1/2
42-222-01 -
42-223-04

Wurzelheber

Root elevators
Elevadores para raíces
Élévateurs de racines
Leve per radici

Wurzelheber

Root elevators
Elevadores para raíces
Élévateurs de racines
Leve per radici

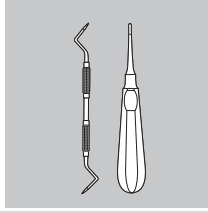

42

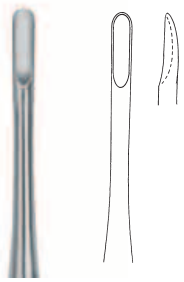

Apical
42-301-00 Fig. 301

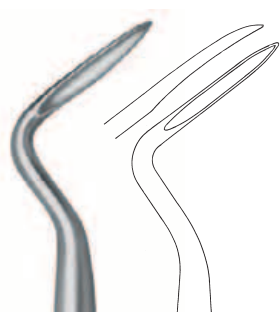

Apical
42-302-00 Fig. 302

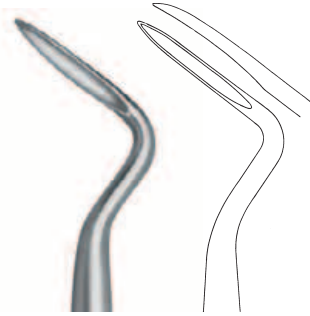

Apical-Flohr
42-303-00 Fig. 303

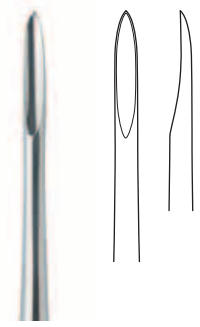

Apical
42-304-00 Fig. 304

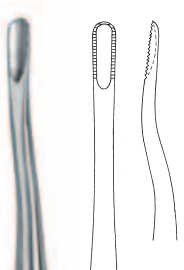

Apical
42-311-00 Fig. 46 R

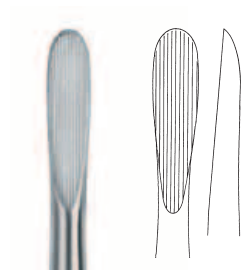

Coleman
42-405-01 Fig. 1

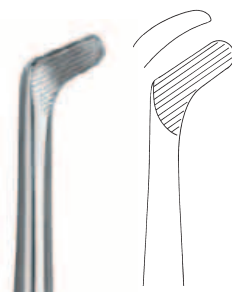

Coleman
42-405-02 Fig. 2 L

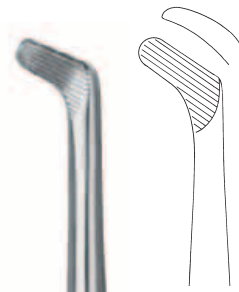

Coleman
42-405-03 Fig. 3 R

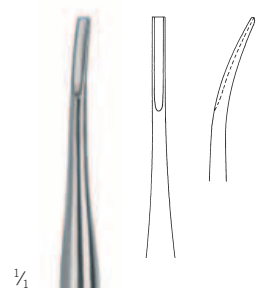

Coupland
42-415-01 Fig. 1

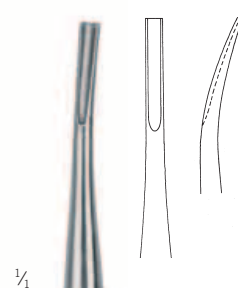

Coupland
42-415-02 Fig. 2

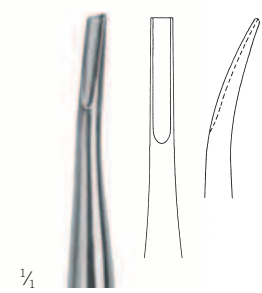

Coupland
42-415-03 Fig. 3



$\frac{1}{2}$
42-301-00 - 42-505-03

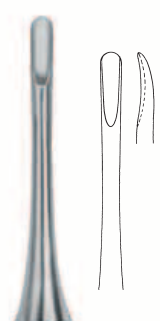

Friedman
42-505-01 Fig. 1

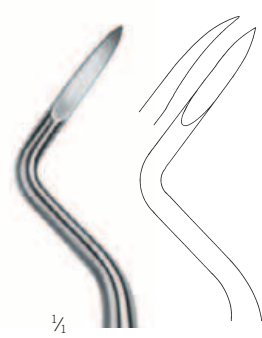

Friedman
42-505-02 Fig. 2 L



Friedman
42-505-03 Fig. 3 R

Wurzelheber

Root elevators

Elevadores para raíces

Elévateurs de racines

Leve per radici



1/2

Hylin
42-508-01 - 42-508-04

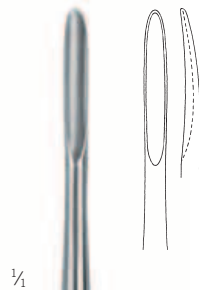

1/1

Hylin
42-508-01 Fig. 1

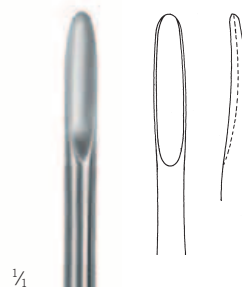

1/1

Hylin
42-508-02 Fig. 2

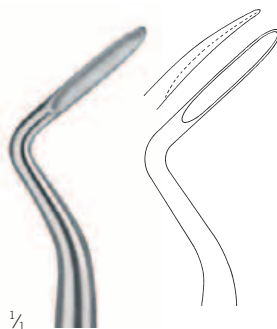

1/1

Hylin
42-508-03 Fig. 3 L

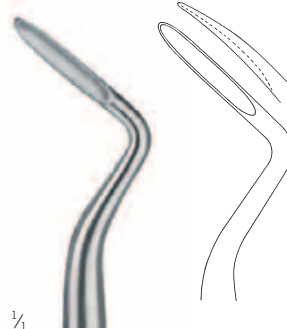

1/1

Hylin
42-508-04 Fig. 4 R



1/2

Bein
42-511-00 - 42-512-02

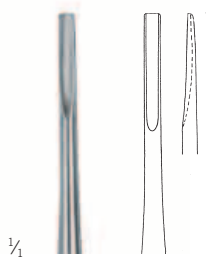

1/1

Bein
42-511-00 Fig. 0

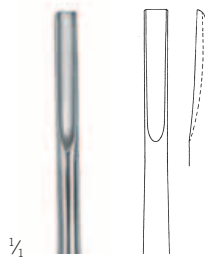

1/1

Bein
42-511-01 Fig. 1

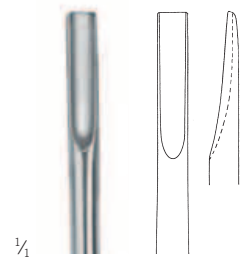

1/1

Bein
42-511-02 Fig. 2

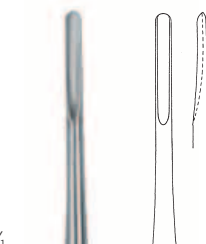

1/1

Bein
42-512-00 Fig. 0

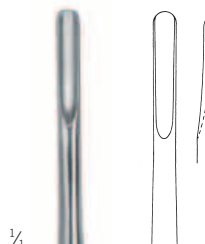

1/1

Bein
42-512-01 Fig. 1

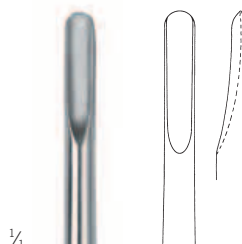

1/1

Bein
42-512-02 Fig. 2

rund
round
redondo
rond
rotondo

Wurzelheber

Root elevators
Elevadores para raíces
Élévateurs de racines
Leve per radici

Wurzelheber

Root elevators
Elevadores para raíces
Élévateurs de racines
Leve per radici

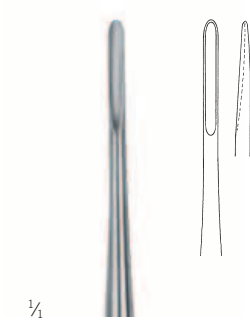
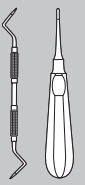

1/1

Bein
42-513-00 Fig. 0

spitz
sharp
agudo
pointu
appuntito

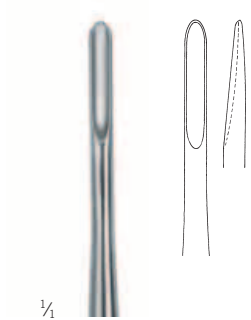

1/1

Bein
42-513-01 Fig. 1

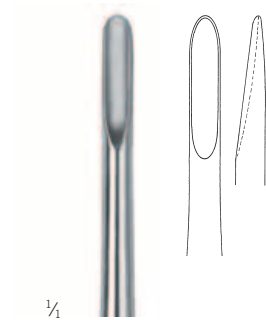

1/1

Bein
42-513-02 Fig. 2

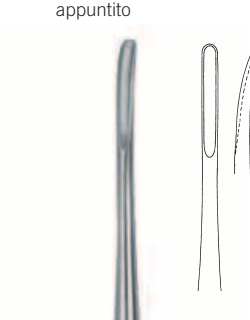

Bein
42-514-00 Fig. 0 A

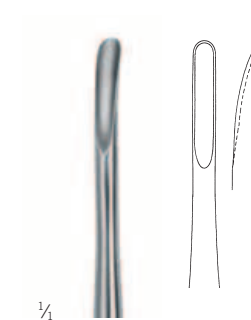

1/1

Bein
42-514-01 Fig. 1 A



1/1

Bein
42-514-02 Fig. 2 A

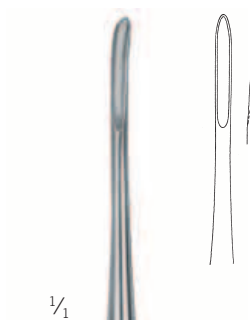

1/1

Bein
42-515-00 Fig. 0 A

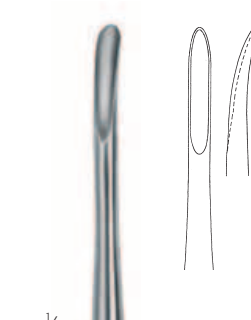

1/1

Bein
42-515-01 Fig. 1 A

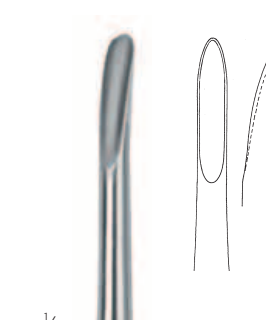

1/1

Bein
42-515-02 Fig. 2 A



1/2

Bein
42-511-00 - 42-512-02

Wurzelheber

Root elevators

Elevadores para raíces

Elévateurs de racines

Leve per radici

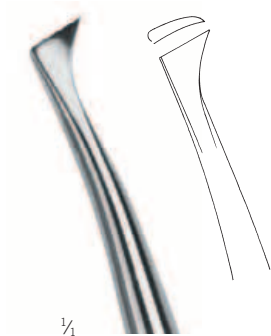

1/4

W. F. Barry
42-533-20 Fig. 320 L

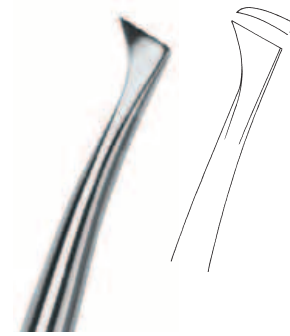

1/4

W. F. Barry
42-533-21 Fig. 321 R

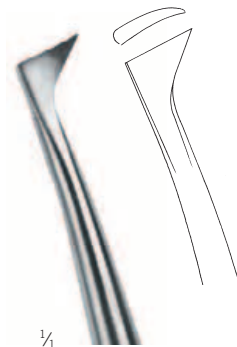

1/4

Barry
42-533-22 Fig. 322

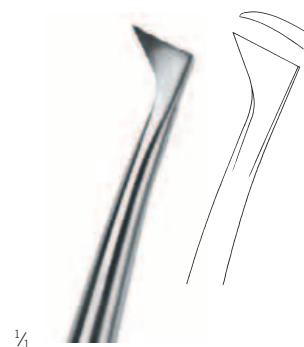

1/4

Barry
42-533-23 Fig. 323



1/2

W. F. Barry
42-533-20 - 42-533-71



1/4

W. F. Barry
42-533-70 Fig. 370 R

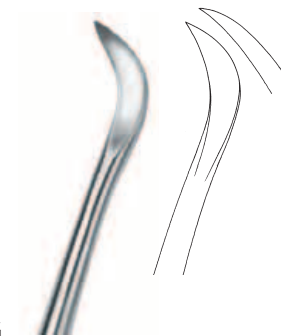

1/4

W. F. Barry
42-533-71 Fig. 371 R

Wurzelheber

Root elevators
Elevadores para raíces
Élévateurs de racines
Leve per radici

Wurzelheber

Root elevators
Elevadores para raíces
Élévateurs de racines
Leve per radici

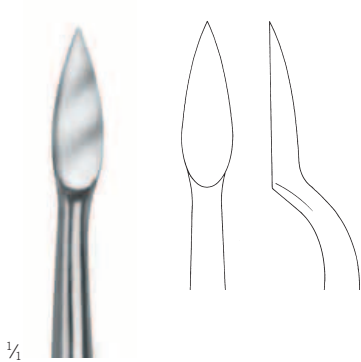
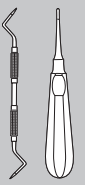

Lecluse
42-561-01 Fig. 1

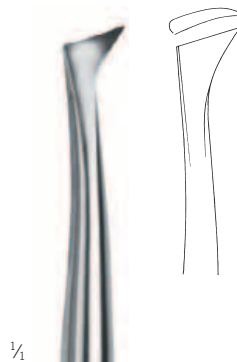

Winter
42-551-05 Fig. 11 L

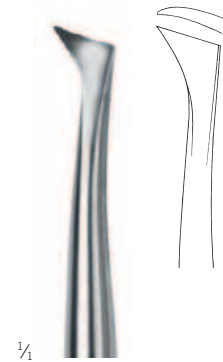

Winter
42-551-08 Fig. 11 R



Winter
42-553-05 Fig. 13 L



Winter
42-553-08 Fig. 13 R



42-551-05 - 42-554-08

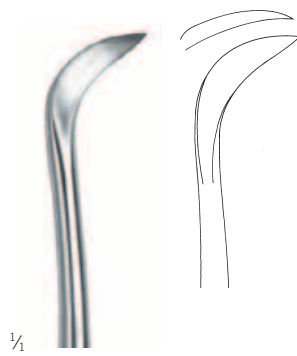

Winter
42-554-05 Fig. 14 L

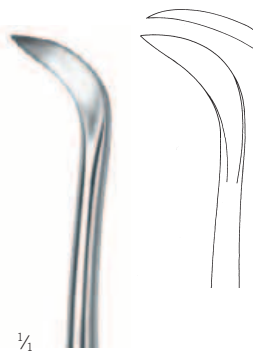

Winter
42-554-08 Fig. 14 R

Wurzelheber

Root elevators

Elevadores para raíces

Elévateurs de racines

Leve per radici



42-567-01
Fig. 1



42-567-02
Fig. 2

Pott
42-567-01 - 42-567-02

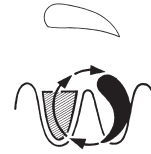

Fig. 1



Fig. 2



42-571-01
Fig. 1 L



42-571-02
Fig. 2 R

Krallenheber
42-571-01 - 42-571-02



42-575-00
Fig. 1



42-575-02
Fig. 2

Wurzelspitzenheber

Root fragment elevators
Elevadores para fragmentos de raíces
Élévateurs de fragments de racines
Leve per frammenti

Wurzelheber

Root elevators
Elevadores para raíces
Élévateurs de racines
Leve per radici

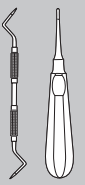

1/2

42-576-01 - 42-577-03

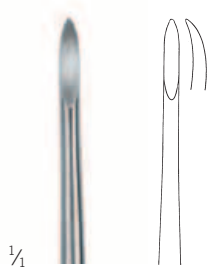

1/4

Warwick-James
42-576-01

Fig. 1

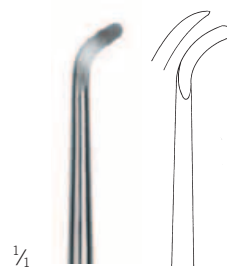

1/4

Warwick-James
42-576-02

Fig. 2 L

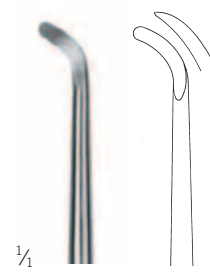

1/4

Warwick-James
42-576-03

Fig. 3 R



1/4

Chompret
42-577-01

Fig. 1

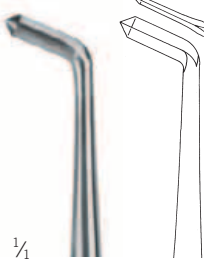

1/4

Chompret
42-577-02

Fig. 2

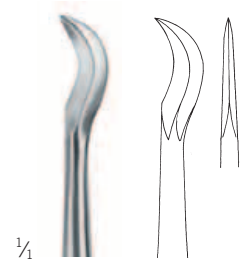

1/4

Chompret
42-577-03

Fig. 3



1/2

Heidebrink
42-582-01 - 42-582-03

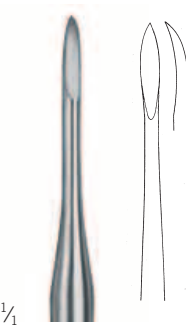

1/4

42-582-01

Fig. 1

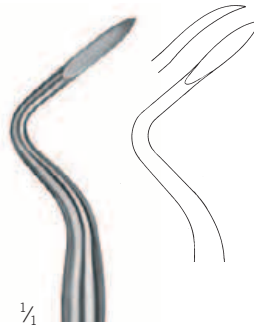

1/4

42-582-02

Fig. 2

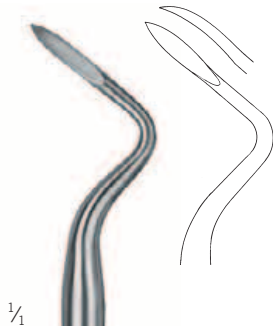

1/4

42-582-03

Fig. 3

Wurzelspitzenheber

Root fragment elevators

Elevadores para fragmentos de raíces

Elévateurs de fragments de racines

Leve per frammenti



1/2

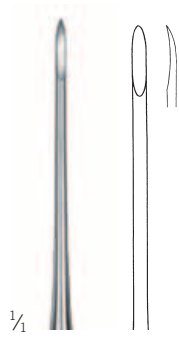

1/1

42-584-01

Fig. 1

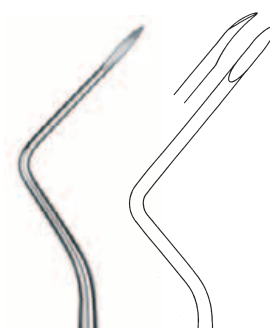

42-584-02

Fig. 2

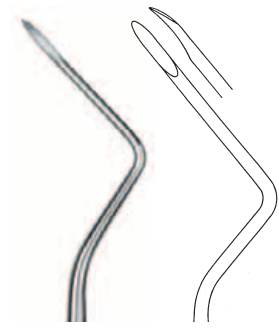

42-584-03

Fig. 3

West
42-584-01 - 42-584-03



1/2

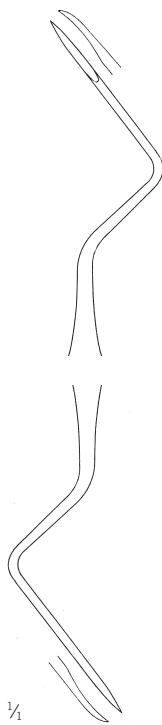

1/1

42-587-01

Fig. 1

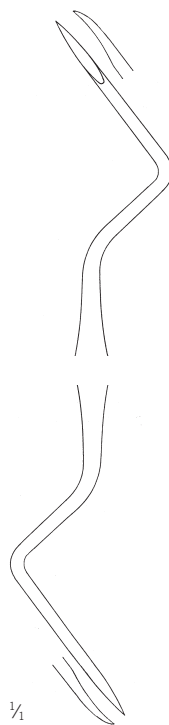

1/1

42-587-02

Fig. 2

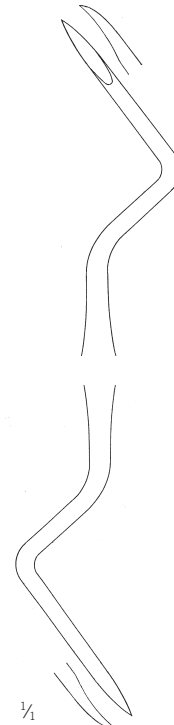

1/1

42-587-03

Fig. 3

Heidebrink
42-587-01 - 42-587-03

42

Spritzen

Syringes
Jeringas
Seringues
Siringhe

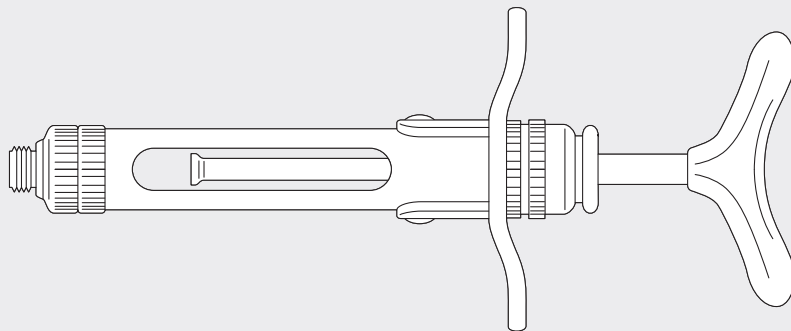

Ampullenspritzen, Injektionskanülen, Spritzen

Cartridge syringes, needles, syringes
Jeringas para cartucho apollas, agujas hipodérmicas
Seringues à ampoule, canules, seringues
Siringhe ampollari, aghi, siringhe



42-602-00

Zylinder-Ampullenspritze
Cylinder cartridge syringe
Jeringa para cartucho ampollas
Seringue à ampoule cylindrique
Siringa ampollare a cilindro

1,8 cc, ohne Aspiration
1,8 cc, without aspiration
1,8 cc, sin aspiración
1,8 cc, sans aspiration
1,8 cc, senza aspirazione

mit metrischem Gewinde
with metric thread
con rosca métrica
avec filetage métrique
con filettatura metrica

42-602-01

Zylinder-Ampullenspritze
Cylinder cartridge syringe
Jeringa para cartucho ampollas
Seringue à ampoule cylindrique
Siringa ampollare a cilindro

2,2 cc, ohne Aspiration
2,2 cc, without aspiration
2,2 cc, sin aspiración
2,2 cc, sans aspiration
2,2 cc, senza aspirazione

mit metrischem Gewinde
with metric thread
con rosca métrica
avec filetage métrique
con filettatura metrica

42-602-04

Zylinder-Ampullenspritze
Cylinder cartridge syringe
Jeringa para cartucho ampollas
Seringue à ampoule cylindrique
Siringa ampollare a cilindro

1,8 cc, ohne Aspiration
1,8 cc, without aspiration
1,8 cc, sin aspiración
1,8 cc, sans aspiration
1,8 cc, senza aspirazione

mit US-Gewinde
with US thread
con rosca tipo US
avec filetage US
con filettatura di tipo US

42-602-05

Zylinder-Ampullenspritze
Cylinder Cartridge Syringe
Jeringa para cartucho ampollas
Seringue à ampoule cylindrique
Siringa ampollare a cilindro

2,2 cc, ohne Aspiration
2,2 cc, without aspiration
2,2 cc, sin aspiración
2,2 cc, sans aspiration
2,2 cc, senza aspirazione

mit US-Gewinde
with US thread
con rosca tipo US
avec filetage US
con filettatura di tipo US

Ampullenspritzen, Injektionskanülen, Spritzen

Cartridge syringes, needles, syringes

Jeringas para cartucho apollas, agujas hipodérmicas

Seringues à ampoule, canules, seringues

Siringhe ampollari, aghi, siringhe

Spritzen

Cartridge syringes

Jeringas para cartucho apollas

Seringues à ampoule

Siringhe ampollari

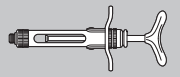

1/2

42-604-00

Zylinder-Ampullenspritze

Cylinder cartridge syringe

Jeringa para cartucho ampollas

Seringue à ampoule cylindrique

Siringa ampollare a cilindro

1,8 cc, mit Aspiration

1,8 cc, with aspiration

1,8 cc, con aspiración

1,8 cc, avec aspiration

1,8 cc, con aspirazione

mit metrischem Gewinde

with metric thread

con rosca métrica

avec filetage métrique

con filettatura metrica

42-604-02

Zylinder-Ampullenspritze

Cylinder cartridge syringe

Jeringa para cartucho ampollas

Seringue à ampoule cylindrique

Siringa ampollare a cilindro

2,2 cc, mit Aspiration

2,2 cc, with aspiration

2,2 cc, con aspiración

2,2 cc, avec aspiration

2,2 cc, con aspirazione

mit metrischem Gewinde

with metric thread

con rosca métrica

avec filetage métrique

con filettatura metrica



42

42-604-01

Zylinder-Ampullenspritze

Cylinder cartridge syringe

Jeringa para cartucho ampollas

Seringue à ampoule cylindrique

Siringa ampollare a cilindro

1,8 cc, mit Aspiration

1,8 cc, with aspiration

1,8 cc, con aspiración

1,8 cc, avec aspiration

1,8 cc, con aspirazione

mit US-Gewinde

with US thread

con rosca tipo US

avec filetage US

con filettatura di tipo US

42-604-04

Zylinder-Ampullenspritze

Cylinder cartridge syringe

Jeringa para cartucho ampollas

Seringue à ampoule cylindrique

Siringa ampollare a cilindro

2,2 cc, mit Aspiration

2,2 cc, with aspiration

2,2 cc, con aspiración

2,2 cc, avec aspiration

2,2 cc, con aspirazione

mit US-Gewinde

with US thread

con rosca tipo US

avec filetage US

con filettatura di tipo US

Ampullenspritzen, Injektionskanülen, Spritzen

Cartridge syringes, needles, syringes
Jeringas para cartucho apollas, agujas hipodérmicas
Seringues à ampoule, canules, seringues
Siringhe ampollari, aghi, siringhe



42-606-00

Zylinder-Ampullenspritze
Cylinder cartridge syringe
Jeringa para cartucho ampollas
Seringue à ampoule cylindrique
Siringa ampollare a cilindro

1,8 cc, mit Aspiration
1,8 cc, with aspiration
1,8 cc, con aspiración
1,8 cc, avec aspiration
1,8 cc, con aspirazione

mit metrischem Gewinde
with metric thread
con rosca métrica
avec filetage métrique
con filettatura metrica

42-606-02

Zylinder-Ampullenspritze
Cylinder cartridge syringe
Jeringa para cartucho ampollas
Seringue à ampoule cylindrique
Siringa ampollare a cilindro

2,2 cc, mit Aspiration
2,2 cc, with aspiration
2,2 cc, con aspiración
2,2 cc, avec aspiration
2,2 cc, con aspirazione

mit metrischem Gewinde
with metric thread
con rosca métrica
avec filetage métrique
con filettatura metrica

42-606-01

Zylinder-Ampullenspritze
Cylinder cartridge syringe
Jeringa para cartucho ampollas
Seringue à ampoule cylindrique
Siringa ampollare a cilindro

1,8 cc, mit Aspiration
1,8 cc, with aspiration
1,8 cc, con aspiración
1,8 cc, avec aspiration
1,8 cc, con aspirazione

mit US-Gewinde
with US thread
con rosca tipo US
avec filetage US
con filettatura di tipo US

42-606-04

Zylinder-Ampullenspritze
Cylinder cartridge syringe
Jeringa para cartucho ampollas
Seringue à ampoule cylindrique
Siringa ampollare a cilindro

2,2 cc, mit Aspiration
2,2 cc, with aspiration
2,2 cc, con aspiración
2,2 cc, avec aspiration
2,2 cc, con aspirazione

mit US-Gewinde
with US thread
con rosca tipo US
avec filetage US
con filettatura di tipo US



42-608-00

Zylinder-Ampullenspritze, 1,8 cc, mit 3 beweglichen Aspirationshaken für sichere Aspiration, mit metrischem Gewinde

Cylinder cartridge syringe, 1,8 cc, with 3 movable aspiration hooks for safe aspiration, with metric thread

Jeringa para cartucho ampollas, 1,8 cc, con 3 ganchos móviles, con rosca métrica

Seringue à ampoule cylindrique, 1,8 cc, avec 3 crochets d'aspiration mobiles pour une aspiration sûre, avec filetage métrique

Siringa ampollare a cilindro, 1,8 cc, con 3 ganci mobili di aspirazione per una sicura aspirazione, con filettatura metrica

42-608-01

Zylinder-Ampullenspritze, 1,8 cc, mit 3 beweglichen Aspirationshaken für sichere Aspiration, mit US-Gewinde

Cylinder cartridge syringe, 1,8 cc, with 3 movable aspiration hooks for safe aspiration, with US thread

Jeringa para cartucho ampollas, 1,8 cc, con 3 ganchos móviles, con rosca tipo US

Seringue à ampoule cylindrique, 1,8 cc, avec 3 crochets d'aspiration mobiles pour une aspiration sûre, avec filetage US

Siringa ampollare a cilindro, 1,8 cc, con 3 ganci mobili di aspirazione per una sicura aspirazione, con filettatura di tipo US

Ampullenspritzen, Injektionskanülen, Spritzen

Cartridge syringes, needles, syringes

Jeringas para cartucho apollas, agujas hipodérmicas

Seringues à ampoule, canules, seringues

Siringhe ampollari, aghi, siringhe

Spritzen

Cartridge syringes

Jeringas para cartucho apollas

Seringues à ampoule

Siringhe ampollari

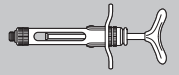

1/4

Injektionskanüle
Hypodermic needle
Agujas hipodérmicas
Canule d'injection
Aghi

42-625-01	Fig. 1	Ø 0,90 x 38 mm
42-625-02	Fig. 2	Ø 0,80 x 32 mm
42-625-12	Fig. 12	Ø 0,70 x 32 mm
42-625-14	Fig. 14	Ø 0,65 x 28 mm
42-625-16	Fig. 16	Ø 0,60 x 25 mm
42-625-18	Fig. 18	Ø 0,50 x 23 mm
42-625-20	Fig. 20	Ø 0,45 x 20 mm



1/2

Zylinder allein
Barrel only
Cilindro suelta
Cylindre seul
Solo cilindro

42-632-01	1 ml
42-632-02	2 ml
42-632-05	5 ml
42-632-10	10 ml
42-632-20	20 ml
42-632-50	50 ml

Luer

Injektionsspritze
Injection needle
Jeringas de inyección
Seringue d'injection
Siringa di iniezione



1/2

42-630-01	1 ml
42-630-02	2 ml
42-630-05	5 ml
42-630-10	10 ml
42-630-20	20 ml
42-630-50	50 ml

Luer

Ampullenspritzen, Injektionskanülen, Spritzen

Cartridge syringes, needles, syringes
Jeringas para cartucho apollas, agujas hipodérmicas
Seringues à ampoule, canules, seringues
Siringhe ampollari, aghi, siringhe



Luer
42-652-00

Ganzmetall-Wasserspritze
All-metal water syringe
Jeringa para agua, de metal
Seringue à eau entièrement métallique
Siringa per acqua interamente metallica

10 ml

mit 1 Kanüle
with 1 needle
con 1 aguja
avec 1 canule
con 1 cannula

selbstfüllend mit Gummidichtung
self filling with rubber gasket
para relleno automático con sellado de goma
autoremplissant avec garniture en caoutchouc
riempire automatico con guarnizione in gomma



Luer
42-652-01

Kanüle Luer Lock, allein
Cannula Luer Lock, only
Cánula Luer Lock, suelta
Canule Luer Lock, seule
Solo cannula Luer Lock

42

Mundspiegel

Mouth mirrors
Espejos de boca
Miroirs à bouche
Specchietti

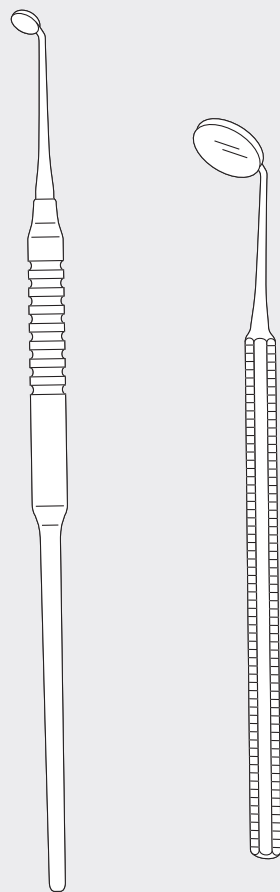

Kehlkopfspiegel, Mundspiegelansätze

Laryngeal mirrors, mouth mirrors
Espejos laringeos, espejos de boca
Miroirs laryngiens, miroirs à bouche
Specchi laringei, specchietti



39-781-08	Fig. 00	Ø 8,5 mm
39-781-10	Fig. 0	Ø 10,5 mm
39-781-12	Fig. 1	Ø 12,5 mm
39-781-14	Fig. 2	Ø 14,5 mm
39-781-16	Fig. 3	Ø 16,5 mm
39-781-18	Fig. 4	Ø 18,5 mm
39-781-20	Fig. 5	Ø 20,5 mm
39-781-22	Fig. 6	Ø 22,5 mm
39-781-24	Fig. 7	Ø 24,5 mm
39-781-26	Fig. 8	Ø 26,5 mm
39-781-28	Fig. 9	Ø 28,5 mm
39-781-30	Fig. 10	Ø 30,5 mm

39-781-08 - 39-781-30

18,5 cm / 7 1/4"

plan, mit festem Handgriff
plane, with fixed handle
plano, con mango fijado
plat, avec manche fixe
plano, con manico fisso

Mundspiegelansätze

Mouth mirrors
Espejos de boca
Miroirs à bouche
Specchietti

Mundspiegel

Mouth mirrors
Espejos de boca
Miroirs à bouche
Specchietti

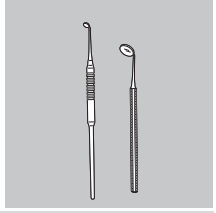

42

Mega Duo

Ø mm	Größe Size Tamaño Taille Dimens.	Rückseite Back surface Superficie del reverso Surface arrière Superficie posteriore	hohl, wirkt vergrößernd, metr. Gewinde concave, enlarging effect, metr. thread cóncavo, con efecto de aumento, rosca métrica creux, avec effet agrandissant, filetage métrique cavo, con effetto di ingrandimento, filettatura metrica	Rhodiumspiegel Rhodium mirror Espejo de rodio Miroir au rhodium Specchio in rodio
10	00			absolut verzerrungsfreies Spiegelbild absolutely distortion-free mirror image imagen reflejada totalmente libre de distorsión image réfléchie sans aucune distorsion immagine riflessa assolutamente priva di distorsioni
18	0			Rhodium beschichtet, metr. Gewinde rhodium-coated, metr. thread con revestimiento de rodio, rosca métrica revêtu de rhodium, filetage métrique con rivestimento in rodio, filettatura metrica
22	4	42-702-22	42-703-22	42-704-22
24	5	42-702-24	42-703-24	42-704-24
22	4			42-705-22 ²⁾ Mega Duo

1) in Verbindung mit 23-448-11 optimal für palatinalen Aufklappungen
with 23-448-11, ideal for palatine flap operations
con 23-448-11 ideal para operación del colgajo palatino
en liaison avec 23-448-11, idéal pour le décapotage de la gencive
in abbinamento a 23-448-11 ottimale per il distacco della gengiva (esposizione radici)

2) mit breiterem Spezialansatz zur Schonung der Wangen und Lippen
with wider, specially designed attachment for cheek and lip protection
con aditamento especial más ancho para proteger mejillas y labios
avec appendice spécial plus large pour protéger la joue et les lèvres
con speciale collo più ampio per proteggere guance e labbra

beidseitig Rhodium beschichtet
rhodium-coated, both sides
ambos lados con revestimiento de rodio
revêtu de rhodium des deux côtés
con rivestimento in rodio su entrambe i lati

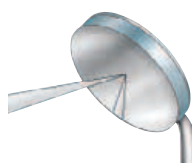

Vorderseite Rhodium beschichtet
Front side rhodium plated
Parte anterior con revestimiento de rodio
Devant revêtu de rhodium
Lato anteriore con rivestimento in rodio

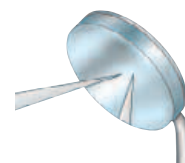

Rückseite Rhodium beschichtet
Rear side rhodium plated
Parte posterior con revestimiento de rodio
Derrrière revêtu de rhodium
Lato posteriore con rivestimento in rodio

Mundspiegelansätze

Mouth mirrors
Espejos de boca
Miroirs à bouche
Specchietti



1/1

Cone Socket

mit konischem Gewindeauslauf
with conical end of thread
con terminal cónica de rosca
avec extrémité filetée conique
con filettatura a estremità conica

nur für Spiegelgriff 42-721-02 geeignet
only suitable for mirror handle 42-721-02
sólo para el mango del espejo 42-721-02
uniquement adapté au poignée de miroir 42-721-02
adatto solo per l'impugnatura dello specchio 42-721-02

Ø mm	Größe Size Tamaño Taille Dimens.	plan plane plano plan piano	hohl, wirkt vergrößernd concave, enlarging effect cóncavo, con efecto de aumento creux, avec effet agrandissant cavo, con effetto di ingrandimento
22	4	42-706-22	42-707-22
24	5	42-706-24	42-707-24



Mikro-Mundspiegel

Micro mouth mirrors
Espejos de boca micro
Miroirs à bouche micro
Specchietti micro

Mundspiegel

Mouth mirrors
Espejos de boca
Miroirs à bouche
Specchietti

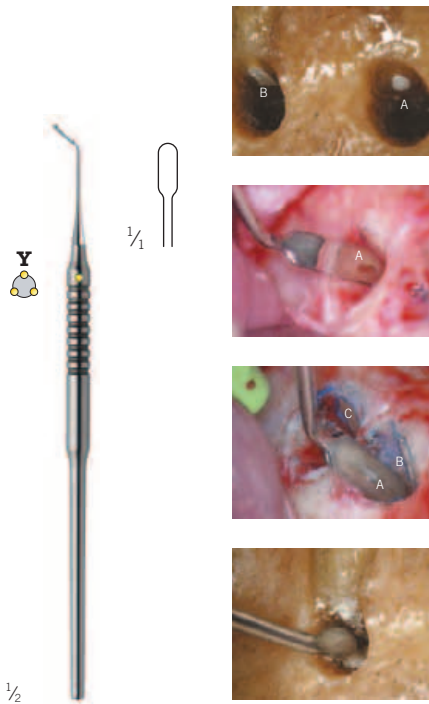
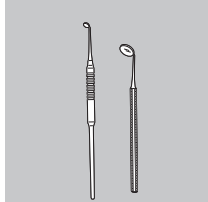

42-710-03

Fig. 1

2,5 mm breit, 45° abgewinkelt
2.5 mm wide, 45° angle
2,5 mm de ancho, ángulo de 45°
2,5 mm de large, coudé à 45°
2,5 mm di larghezza, con angolo di 45°

Mikrometallspiegel mit festem Griff
Micro metal mirror with fixed handle
Micro espejo metálico con mango fijo
Micro miroir métallique avec poignée fixe
Micro specchio metallico con impugnatura rigida
für Wurzelspitzenresektion
for apicoectomy
para la apicectomía
pour résection de l'apex de la racine
per apicectomia



42-710-05

Fig. 2

Ø 5 mm, 45° abgewinkelt
Ø 5 mm, 45° angle
Ø 5 mm, ángulo de 45°
Ø 5 mm, coudé à 45°
Ø 5 mm, con angolo di 45°

Mikrometallspiegel mit festem Griff
Micro metal mirror with fixed handle
Micro espejo metálico con mango fijo
Micro miroir métallique avec poignée fixe
Micro specchio metallico con impugnatura rigida
für Wurzelspitzenresektion
for apicoectomy
para la apicectomía
pour résection de l'apex de la racine
per apicectomia



42-710-06 - 42-711-05

Rhodium-Mikrospiegelansatz
Rhodium micro mirror
Micro espejo de rodio
Micro miroir au rhodium
Micro specchio metallico

für höchste Ansprüche unter dem Mikroskop
for highest requirements under the microscope
para las más altas exigencias bajo el microscopio
pour des exigences extrêmes sous le microscope
per i massimi requisiti al microscopio
passend für jeden Spiegelgriff, metrisches Gewinde
suitable for any mirror handle, metric thread
apropiado para cualquier mango de espejo, rosca métrica
adapté à chaque poignée de miroir, filetage métrique
appropriato a ogni tipo di impugnatura di specchio, filettatura metrica

Ø 3,0 mm	Fig. 1	42-711-03
Ø 5,0 mm	Fig. 2	42-711-05
□ 3 x 6 mm	Fig. 3	42-710-06

GR = grau grey gris grigio
Y = gelb yellow amarillo giallo
R = rot red rojo rosso
G = grün green verde verde
V = violett violet violeta violet viola
W = weiß white blanco bianco
B = blau blue azur bleu blu
N = schwarz black negro noir nero

Wangenabhalter / Mundspiegelgriffe

Cheek retractors / mouth mirror handles
 Separadores / mangos para espejos de boca
 Ecarteurs / manches pour miroirs à bouche
 Divaricatori / manici per specchietti



**Hilger
42-715-01**

Wangenabhalter-Ansatz,
 passend für jeden
 Mundspiegelgriff
 Cheek retractor, exchangeable
 attachment, suitable for any mouth
 mirror handle
 Separador de la mejilla,
 intercambiable, apropiado para
 cualquier mango de espejo
 Écarteur de joue,
 interchangeable, adapté
 à chaque poignée de miroir
 Separatore di guancia,
 intercambiabile, appropriato a ogni
 tipo di impugnatura di specchio

1/2



1/2



1/2



1/2

**Hilger
42-715-00**

18 cm / 7 1/8"
 Wangenabhalter mit Griff
 Cheek retractor with handle
 Separador de la mejilla con mango
 Écarteur de joue avec poignée
 Separatore di guancia con manico

**Secco
42-721-01**

14 cm / 5 4/8"
 metrisches Gewinde
 metric thread
 rosca métrica
 filetage métrique
 filettatura metrica

**Secco-Cone Socket
42-721-02**

14 cm / 5 4/8"
 metrisches Gewinde mit konischem Ansatz
 metric thread with conical end
 rosca métrica con extremo cónico
 filetage métrique avec extrémité conique
 filettatura metrica con estremità conica

**Secco
42-723-01**

13 cm / 5 1/8"
 Achtkant
 octagonal
 octagonales
 octogonal
 ottagonale



42-706-22 ... 42-707-24



1/2



1/2



1/2



1/2



1/2

42-726-02

12 cm / 4 6/8"
 Achtkant
 octagonal
 octagonales
 octogonal
 ottagonale
 metrisches Gewinde
 metric thread
 rosca métrica
 filetage métrique
 filettatura metrica

42-728-02

12 cm / 4 6/8"
 Achtkant
 octagonal
 octagonales
 octogonal
 ottagonale
 metrisches Gewinde
 metric thread
 rosca métrica
 filetage métrique
 filettatura metrica

**Martin Grip
42-746-02**

12 cm / 4 6/8" / Ø 6 mm
 Rundgriff
 round handle
 mango redondo
 poignée ronde
 impugnatura tonda
 metrisches Gewinde
 metric thread
 rosca métrica
 filetage métrique
 filettatura metrica

**Martin Ergo
42-755-02**

14 cm / 5 4/8" / Ø 11 mm
 metrisches Gewinde
 metric thread
 rosca métrica
 filetage métrique
 filettatura metrica

**Martin Grip
42-757-08**

14 cm / 5 4/8" / Ø 8 mm
 metrisches Gewinde
 metric thread
 rosca métrica
 filetage métrique
 filettatura metrica

43

Reinigungsinstrumente, Parodontologie

Scalers, periodontology

Limpiadores de sarro, parodontología

Instruments à détartrer, parodontologie

Ablatori di tartaro, parodontologia

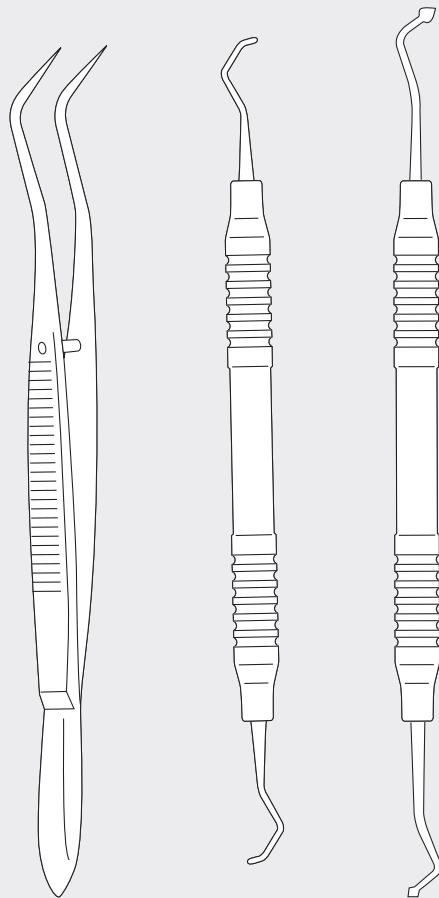

Scaler, supragingivaler Einsatz

Scalers, supragingival

Limpiadores de sarro, supragingival

Instruments à détartrer, supragingival

Ablatori di tartaro, supragingival

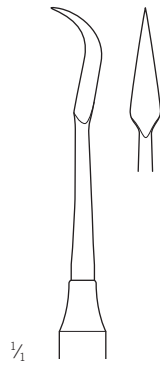

43-247-01

Fig. 1

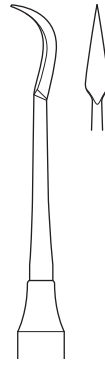

43-247-02

Fig. 2

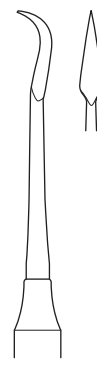

43-247-03

Fig. 3



43-247-32

Fig. 32

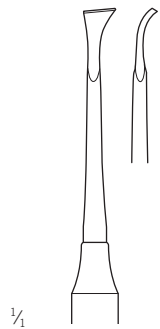

43-247-33

Fig. 33

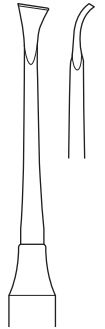

43-247-34

Fig. 34



43-247-35

Fig. 35



43-247-36

Fig. 36

43-247-01 - 43-247-36

17,5 cm / 6 7/8"

massiver Griff, 6 mm

solid handle, 6 mm

mango sólido, 6 mm

poignée massive, 6 mm

solida impugnatura, 6 mm

Scaler, supragingivaler Einsatz

Scalers, supragingival
 Limpiadores de sarro, supragingival
 Instruments à détartrer, supragingival
 Ablatori di tartaro, supragingival

Parodontologie

Periodontology
 Parodontología
 Parodontologie
 Parodontologia

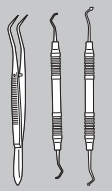

1/4

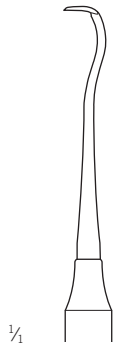

Jaquette
 43-271-33
 Fig. 33

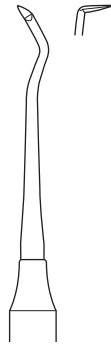

Jaquette
 43-271-34
 Fig. 34

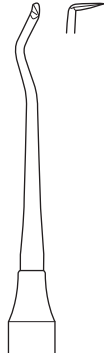

Jaquette
 43-271-35
 Fig. 35

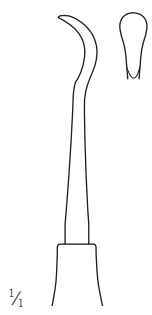

Cumine
 43-282-04
 Fig. 33

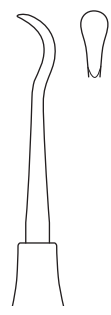

Mitchell
 43-283-04
 Fig. 34

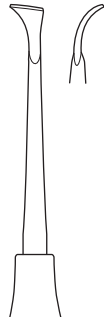

43-288-33
 Fig. 33/34



Younger-Good
 43-291-07
 Fig. 33/34

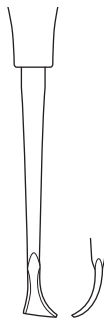
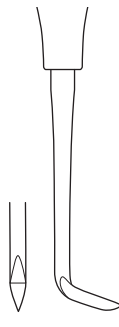
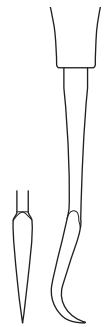

43-271-33 - 43-283-04
 17,5 cm / 6 7/8"
 massiver Griff, 6 mm
 solid handle, 6 mm
 mango sólido, 6 mm
 poignée massive, 6 mm
 solida impugnatura, 6 mm

Scaler, supragingivaler Einsatz

Scalers, supragingival

Limpiadores de sarro, supragingival

Instruments à détartrer, supragingival

Ablatori di tartaro, supragingival



1/4

43-311-05 -
43-311-11

17,5 cm / 6 7/8"

Hohlgriff, 8 mm
hollow handle, 8 mm
mango hueco, 8 mm
poignée creuse, 8 mm
manico cavo, 8 mm

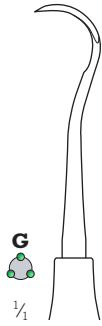

Towner
43-311-05

Fig. 5/33

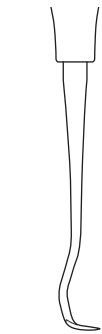

Frontzähne, Prämolaren,
universell, auch approximal
Incisors, premolars,
universal, also approximal
Incisivos, premolares,
universal, también aproximal
Incisives, prémolaires,
universel, aussi approximal
Incisivi, premolari,
universali nonché contigui



McCall
43-311-13

Fig. 13S/14S



Seitenzähne, mesial/distal
Besonders gut für Interdental-
räume im Molarenbereich
Lateral teeth, mesial/distal
Particularly useful for working in
interdental spaces in molar region
Dientes laterales, mesial/distal
Esp. indicado para espacios
interdentales en la región molar
Dents latérales, mésial/distal
Particulièrement adapté aux
espaces interdentaires dans zone
molaire
Denti laterali, mesiali/distali
Particolarmente adatto agli spazi
interdentali nel regione molare



McCall
43-311-14

Fig. 13SM/14



Seitenzähne, mesial / distal,
wie 13S/14S mit abgerundeter
Spitze
Lateral teeth; mesial/distal,
like 13S/14S, with rounded tip
Dientes laterales, mesial/ distal,
como 13S/14S, pero con punta
redondeada
Dents latérales, mésial/distal,
comme 13S/14S avec pointe
arrondie
Denti laterali, mesiali/distali,
come 13S/14S con punta
arrotondata



Taylor
43-311-15

Fig. T 2/3



Frontzähne, Prämolaren,
Molaren, universell
Besonders gut für Interdental-
räume im Molarenbereich
Incisors, premolars, molars,
universal
Particularly useful for working
in interdental spaces in molar
region
Incisivos, premolares, molares,
universal
Esp. indicado para espacios
interdentales en la región molar
Incisives, prémolaires, molaires,
universel
Particulièrement adapté aux
espaces interdentaires dans zone
molaire
Incisivi, premolari, molari,
universali
Particolarmente adatto agli spazi
interdentali nel regione molare

GR = grau
grey
gris
gris
grigio

Y = gelb
yellow
amarillo
jaune
giallo

R = rot
red
rojo
rouge
rosso

G = grün
green
verde
vert
verde

V = violett
violet
violeta
violet
viola

W = weiß
white
blanco
blanc
bianco

B = blau
blue
azur
bleu
blu

N = schwarz
black
negro
noir
nero

Scaler, supragingivaler Einsatz

Scalers, supragingival
 Limpiadores de sarro, supragingival
 Instruments à détartrer, supragingival
 Ablatori di tartaro, supragingival

Parodontologie

Periodontology
 Parodontología
 Parodontologie
 Parodontologia

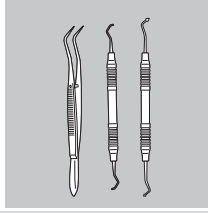

43

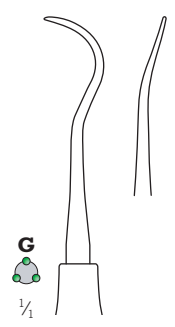

Mc Call
 43-784-18
 Fig. 17/18

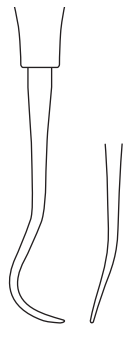

Universal
 universal
 universal
 universel
 universale

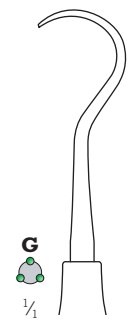

Towner
 43-311-16
 Fig. 15/30



Zum Entfernen von hartnäckigem Zahnstein
 For removing stubborn tartar/scale
 Para quitar sarro y cálculo persistentes
 Pour enlever la tartre dentaire tenace
 Per la rimozione di tartaro persistente

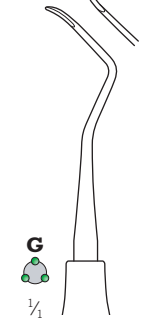

43-311-17
 Fig. U 135



sehr schwer zugängliche Approximalflächen
 for hard-to-access approximal surfaces
 para superficies aproximales poco accesibles
 pour surfaces proximales d'accès très difficile
 per superfici contigue difficilmente accessibili



43-311-18
 Fig. Cl 2/3



Frontzähne, Prämolaren, Molaren, universell
 Incisors, premolars, molars, universal
 Incisivos, premolares, molares, universal
 Incisives, prémolaires, molaires, universel
 Incisivi, premolari, molari, universali

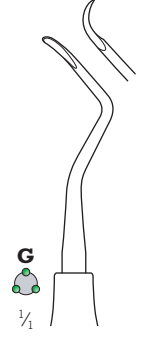

43-311-19
 Fig. M 23



Frontzähne, Prämolaren, mesial/distal
 Incisors, premolars, mesial/distal
 Incisivos, premolares, mesial/distal
 Incisives, prémolaires, mésial/distal
 Incisivi, premolari, mesiali/distali

43-784-18 -
 43-311-19
 17,5 cm / 6 7/8"
 Hohlgriff, 8 mm
 hollow handle, 8 mm
 mango hueco, 8 mm
 poignée creuse, 8 mm
 manico cavo, 8 mm

Scaler, supragingivaler Einsatz

Scalers, supragingival

Limpiadores de sarro, supragingival

Instruments à détartrer, supragingival

Ablatori di tartaro, supragingival

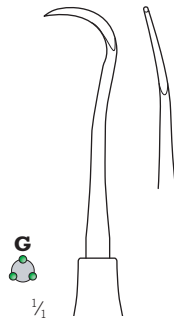

Hygienist
43-312-06
Fig. H6/H7



Hygienist
43-312-10
Fig. H6/H7

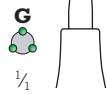
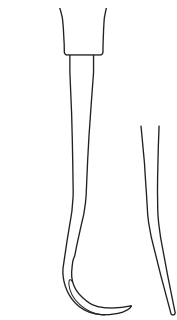

43-314-00
Fig. 204

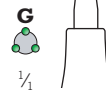

43-314-01
Fig. 204 S

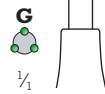

43-314-02
Fig. 204 SD

17,5 cm / 6 3/4"

Hohlgriff, 8 mm
hollow handle, 8 mm
mango hueco, 8 mm
poignée creuse, 8 mm
manico cavo, 8 mm

Frontzähne, Prämolaren,
mesial/distal
Besonders gut im
Interdentalraum

Incisors, premolars,
mesial/distal
Particularly useful for
interdental spaces

17,5 cm / 6 3/4"

Hohlgriff, 10 mm
hollow handle, 10 mm
mango hueco, 10 mm
poignée creuse, 10 mm
manico cavo, 10 mm

Frontzähne, Prämolaren,
mesial/distal
Besonders gut im
Interdentalraum

Incisors, premolars,
mesial/distal
Particularly useful for
interdental spaces

17,5 cm / 6 3/4"

Hohlgriff, 8 mm
hollow handle, 8 mm
mango hueco, 8 mm
poignée creuse, 8 mm
manico cavo, 8 mm

Molaren, universell
Molars, universal
Molares, universal
Molaires, universel
Molari, universale

17,5 cm / 6 3/4"

Hohlgriff, 8 mm
hollow handle, 8 mm
mango hueco, 8 mm
poignée creuse, 8 mm
manico cavo, 8 mm

Molaren, universell
Molars, universal
Molares, universal
Molaires, universel
Molari, universale

17,5 cm / 6 3/4"

Hohlgriff, 8 mm
hollow handle, 8 mm
mango hueco, 8 mm
poignée creuse, 8 mm
manico cavo, 8 mm

Frontzähne, Prämolaren,
mesial/distal

Incisors, premolars,
mesial/distal

Incisivos, premolares,
mesial/distal

Incisives, prémolaires,
mésial/distal

Incisivi, premolari,
mesiali/distali

43-312-06 -
43-314-02
17,5 cm / 6 3/4"

Hohlgriff, 8 mm
hollow handle, 8 mm
mango hueco, 8 mm
poignée creuse, 8 mm
manico cavo, 8 mm

Incisivos, premolares,
mesial/distal
Esp. indicado para los
espacios interdentes

Incisives, prémolaires,
mésial/distal
Particulièrement adapté aux
espaces inter-dentaires

Incisivi, premolari,
mesiali/distali
Particolarmente adatto agli
spazi interdentali

Incisivos, premolares,
mesial/distal
Esp. indicado para los
espacios interdentes

Incisives, prémolaires,
mésial/distal
Particulièrement adapté aux
espaces inter-dentaires

Incisivi, premolari,
mesiali/distali
Particolarmente adatto agli
spazi interdentali

GR = grau
grey
gris
gris
grigio

Y = gelb
yellow
amarillo
jaune
giallo

R = rot
red
rojo
rouge
rosso

G = grün
green
verde
vert
verde

V = violett
violet
violeta
violet
viola

W = weiß
white
blanco
blanc
bianco

B = blau
blue
azur
blanc
blu

N = schwarz
black
negro
noir
nero

Scaler, supragingivaler Einsatz

Scalers, supragingival
 Limpiadores de sarro, supragingival
 Instruments à détartrer, supragingival
 Ablatori di tartaro, supragingival

Parodontologie

Periodontology
 Parodontología
 Parodontologie
 Parodontologia

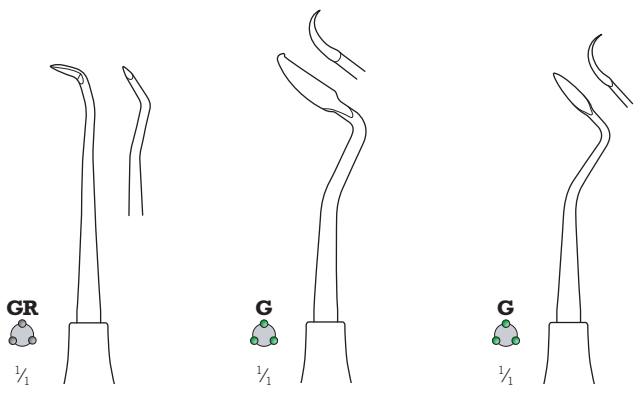
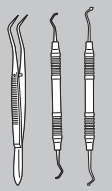

Zürich
43-318-04

43-321-06
Fig. CC 6

43-321-23
Fig. T 2/3

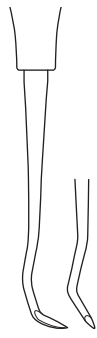

Reinigen von Kavitäten nach WSR

For cleaning cavities following apicoectomy

Para limpiar cavidades después de la apicectomía

Pour nettoyer les cavités après la résection de l'apex

Per la pulizia delle cavità in seguito a interventi di apicectomia

Frontzähne, Prämolaren, Molaren, universell

Incisors, premolars, molars, universal

Incisivos, premolares, molares, universal

Incisives, prémolaires, molaires, universel

Incisivi, premolari, molari, universali

43-318-14 -
43-321-23

17,5 cm / 6 3/4"

Hohlgriff, 8 mm
 hollow handle, 8 mm
 mango hueco, 8 mm
 poignée creuse, 8 mm
 manico cavo, 8 mm

Scaler, supragingivaler Einsatz

Scalers, supragingival

Limpiadores de sarro, supragingival

Instruments à détartrer, supragingival

Ablatori di tartaro, supragingival

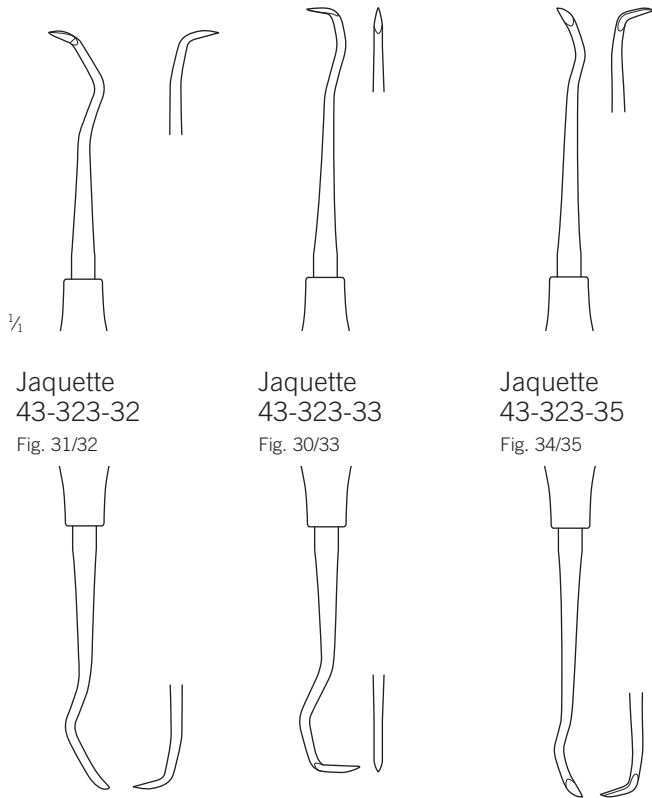

43-323-32 -
43-323-35

17,5 cm / 6 7/8"

Hohlgriff, 8 mm
hollow handle, 8 mm
mango hueco, 8 mm
poignée creuse, 8 mm
manico cavo, 8 mm

Scaler, supragingivaler Einsatz

Scalers, supragingival
 Limpiadores de sarro, supragingival
 Instruments à détartrer, supragingival
 Ablatori di tartaro, supragingival

Parodontologie

Periodontology
 Parodontología
 Parodontologie
 Parodontologia

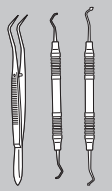

1/4

43-326-31 -
 43-326-36
 17,5 cm / 6 7/8"
 Hohlgriff, 8 mm
 hollow handle, 8 mm
 mango hueco, 8 mm
 poignée creuse, 8 mm
 manico cavo, 8 mm

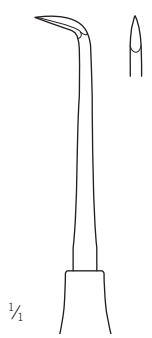

Goldman-Fox
 43-326-31
 Fig. 1

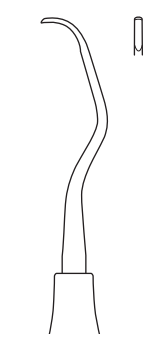

Goldman-Fox
 43-326-32
 Fig. 2

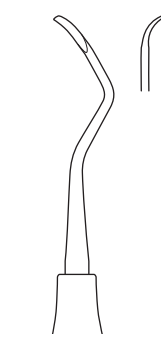

Goldman-Fox
 43-326-33
 Fig. 3

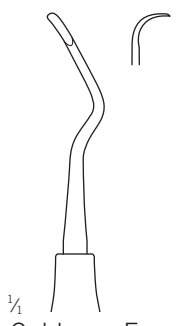

Goldman-Fox
 43-326-34
 Fig. 4

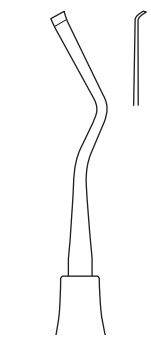

Goldman-Fox
 43-326-35
 Fig. 5

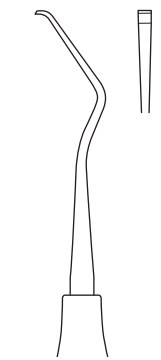
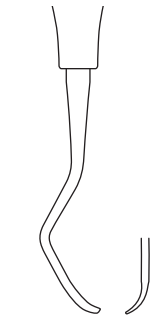

Goldman-Fox
 43-326-36
 Fig. 6

Scaler, supragingivaler Einsatz, Knochenfeilen

Scalers, supragingival, bone files

Limpiadores de sarro, supragingival, limas de hueso

Instruments à détartrer, supragingival, râpes à os

Ablatori di tartaro, supragingival, lime e raspe per osso

Mercitan
43-328-05
Fig. SH 5

Ward-Kirkland
43-330-10
Fig. 1

Crane-Kaplan
43-330-20
Fig. 2

Crane-Kaplan
43-330-30
Fig. 3

White
43-358-12
Fig. 12B

Hirschfeld
43-315-03
Fig. 3/7

Hirschfeld
43-315-05
Fig. 5/11

43-328-05 -
43-358-12
17,5 cm / 6 7/8"
massiver Griff, 6 mm
solid handle, 6 mm
mango sólido, 6 mm
poignée massive, 6 mm
solida impugnatura, 6 mm

43-315-03 -
43-315-05
17,5 cm / 6 7/8"
Hohlgriff, 8 mm
hollow handle, 8 mm
mango hueco, 8 mm
poignée creuse, 8 mm
manico cavo, 8 mm

Feile
File
Lima
Lime
Lima

Zur Entfernung von granulätösem Gewebe aus supra- und infraosären Taschen

For removal of granulomatous tissue from supra- and infrabone pockets

Para quitar el tejido de granulación en las bolsas supra-alveolares e intra-alveolares

Pour enlever le tissu granulomateux de poches supraosseuses et infraosseuses

Per la rimozione di tessuto granulomatoso di tasche sopraossee e infraossee

Parodontalfeile

Periodontal file
Lima parodontal
Lime parodontale
Lima periodontale

Parodontologie

Periodontology
Parodontología
Parodontologie
Parodontologia

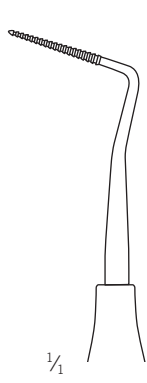
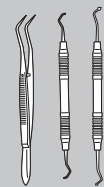

1/1

43-893-01

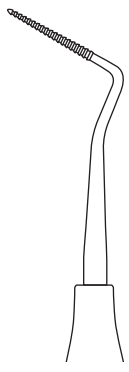

43-893-02



Orban
43-893-06

Fig. 12/13



43-893-08

Fig. 12/12



modifiziert
modified
modificado
modifié
modificato

Zur Entfernung von granulomatösem Gewebe aus supra- und infraossären Taschen

For removal of granulomatous tissue from supra- and infrabone pockets

Para quitar el tejido de granulación en las bolsas supra-alveolares e intra-alveolares

Pour enlever le tissu granulomateux de poches supraosseuses et infraosseuses

Per la rimozione di tessuto granulomatoso di tasche soprassee e infraossee

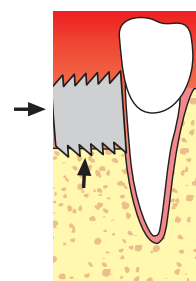

1/1

43-893-01 -
43-893-08

17,5 cm / 6 7/8"

Hohlgriff, 8 mm
hollow handle, 8 mm
mango hueco, 8 mm
poignée creuse, 8 mm
manico cavo, 8 mm

Parodontalfeile

Periodontal file
Lima parodontal
Lime parodontale
Lima periodontale

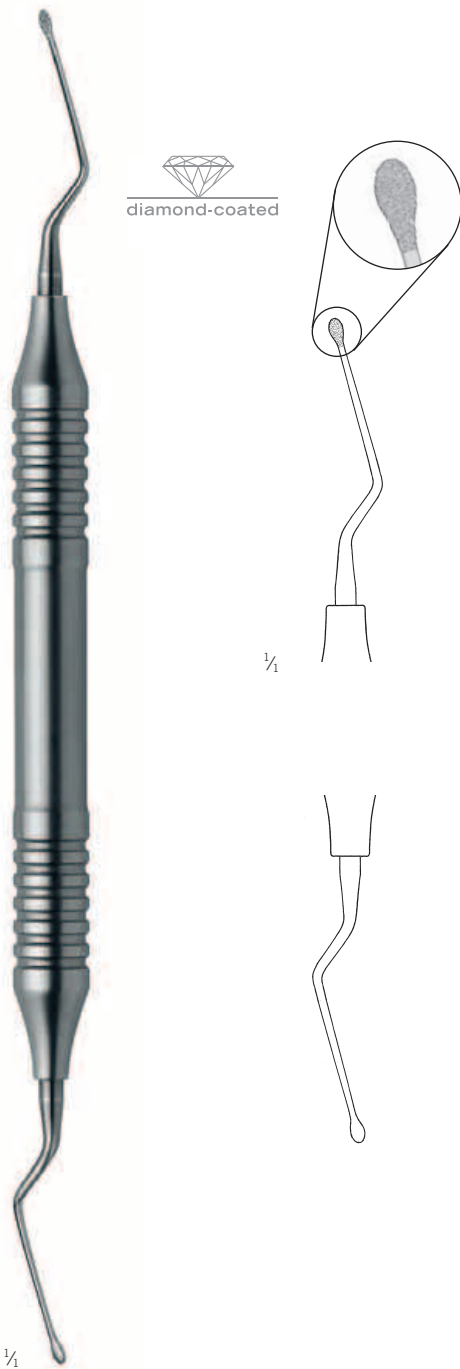

Roncati
43-810-00

17,5 cm / 6 7/8"

Hohlgriff, 10 mm
hollow handle, 10 mm
mango hueco, 10 mm
poignée creuse, 10 mm
manico cavo, 10 mm

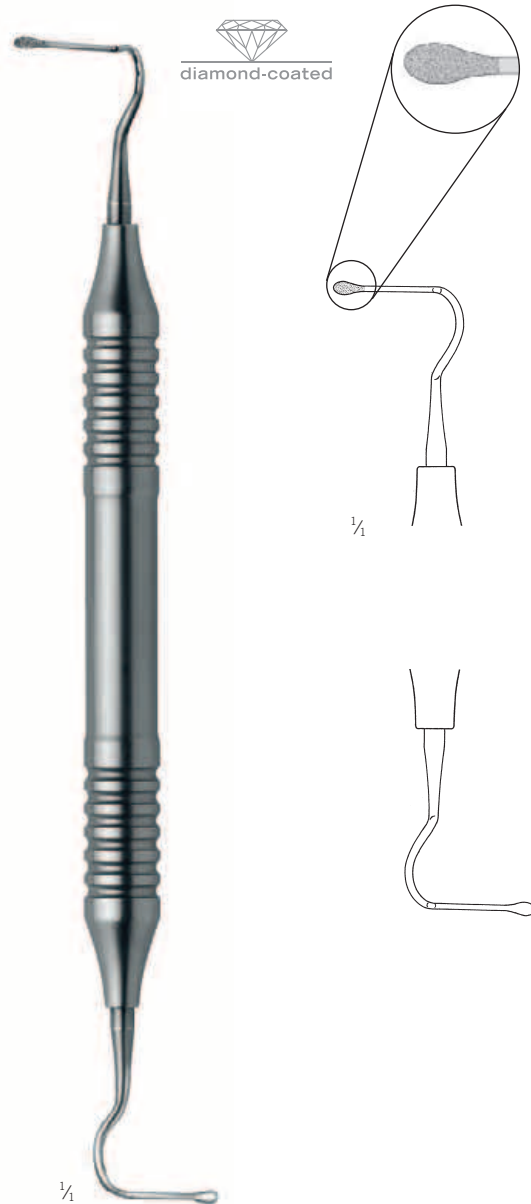

Roncati
43-810-01

17,5 cm / 6 7/8"

Hohlgriff, 10 mm
hollow handle, 10 mm
mango hueco, 10 mm
poignée creuse, 10 mm
manico cavo, 10 mm

Parodontalmeißel

Periodontal chisels
Cinceles de periodoncia
Burins de parodontie
Sgorbie per parodontologia

Parodontologie

Periodontology
Parodontología
Parodontologie
Parodontologia

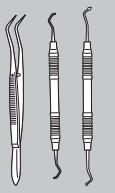

Mini-Meißel
Mini chisel
Mini cincel
Mini burin
Mini scalpello

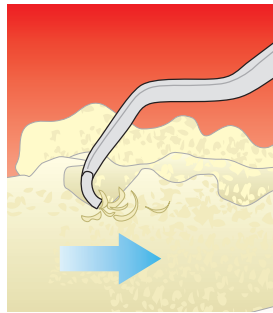

1/4

Rhodes
43-363-01

Fig. 36/37

17,5 cm / 6 7/8"

Hohlgriff, 8 mm
hollow handle, 8 mm
mango hueco, 8 mm
poignée creuse, 8 mm
manico cavo, 8 mm

Parodontalmeißel

Periodontal chisels
Cinceles de periodoncia
Burins de parodontie
Sgorbie per parodontologia

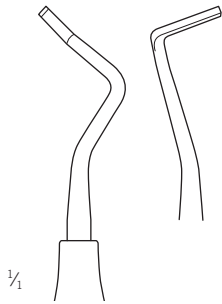

Ochsenbein
43-365-03

Fig. 3

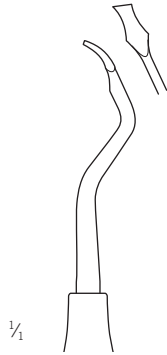
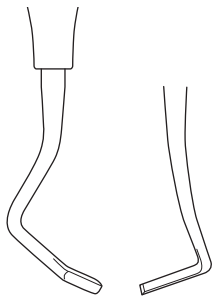

Ochsenbein
43-365-04

Fig. 4

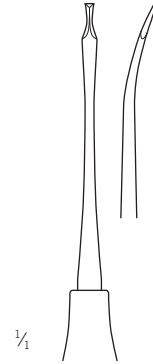

Fedi
43-366-01

Fig. 1

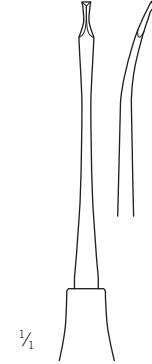

Fedi
43-366-02

Fig. 2

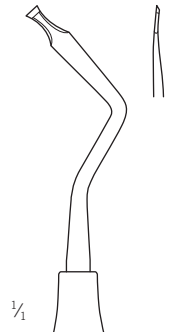

Fedi
43-366-03

Fig. 3

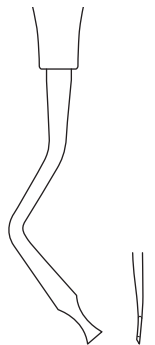

Für Lappenoperationen. Auch für kleinere Knochenkorrekturen
For flap operation. Also for minor bone corrections
Para operaciones de colgajo y correcciones óseas menores
Pour les opérations sur les lambeaux. Aussi pour corrections des os minimes
Per operazioni sui lembi. Anche per correzioni ossee minori

43-365-03 -
43-366-03

17,5 cm / 6 7/8"

Hohlgriff, 8 mm
hollow handle, 8 mm
mango hueco, 8 mm
poignée creuse, 8 mm
manico cavo, 8 mm

Küretten, subgingivaler Einsatz

Curettes, subgingival
Curetas, subgingival
Curettes, subgingival
Curette, subgingivale

Parodontologie

Periodontology
Parodontología
Parodontologie
Parodontologia

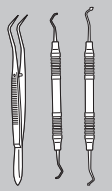

43

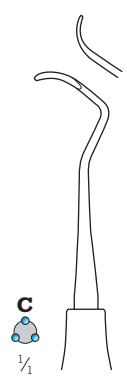

Columbia
43-290-13
Fig. 13/14



Front- und Seitenzähne,
universell
Incisors and lateral teeth,
universal
Incisivos y dientes
laterales, universal
Incisives et dents latérales,
universel
Incisivi e denti laterali, universali

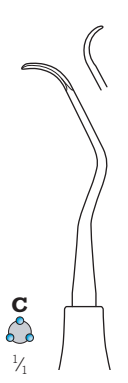

Columbia
43-290-20
Fig. 2R/2L



Frontzähne, universell
Incisors, universal
Incisivos, universal
Incisives, universal
Incisivi, universali



Columbia
43-290-40
Fig. 4R/4L



Seitenzähne, universell
Lateral teeth, universal
Dientes laterales, universal
Dents latérales, universel
Denti laterali, universali

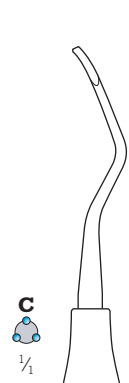

43-292-02
Fig. GX4



Front- und Seitenzähne,
universell
Incisors and lateral teeth,
universal
Incisivos y dientes laterales,
universal
Incisives et dents latérales,
universel
Incisivi e denti laterali,
universali



Mc Call
43-784-02
Fig. 17S/18S



Universal
bifurkale Wurzelflächen
universal
bifurcate root surfaces
universal
superficies radiculares
bifurcadas
universal
surface de racine bifurcale
universali
superfici di radici bifurcate

43-290-13 -
43-784-02 -

17,5 cm / 6 7/8"

Universalkürette
Universal curette
Cureta universal
Curette universelle
Curetta universale

Hohlgriff, 8 mm
hollow handle, 8 mm
mango hueco, 8 mm
poignée creuse, 8 mm
manico cavo, 8 mm

- GR** = grau
grey
gris
gris
grigio
- Y** = gelb
yellow
amarillo
jaune
giallo
- R** = rot
red
rojo
rouge
rosso
- G** = grün
green
verde
vert
verde
- V** = violett
violet
violeta
violet
violeta
- W** = weiß
white
blanco
blanc
bianco
- B** = blau
blue
azur
bleu
blu
- C** = hellblau
light-blue
azul claro
bleu clair
azzurro

Küretten, subgingivaler Einsatz

Curettes, subgingival

Curetas, subgingival

Curettes, subgingival

Curette, subgingivale

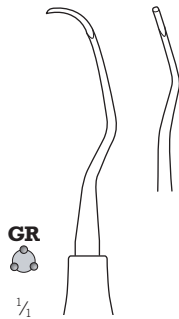

Langer
43-293-02
43-294-02

Fig. 1/2

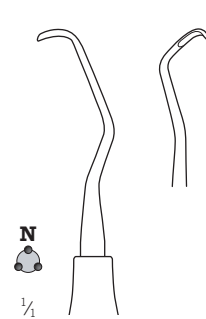

Langer
43-293-04
43-294-04

Fig. 3/4



Langer
43-293-06
43-294-06

Fig. 5/6



Unterkiefer,
Seitenzahnbereich,
mesial / distal
Mandible, lateral teeth,
mesial / distal
Maxilar inferior,
región dientes laterales,
mesial / distal
Mandibule, zone
des dents latérales,
mésial / distal
Mascella inferiore,
settore dei denti laterali,
mesiali / distali



Oberkiefer, Seitenzahnbereich,
mesial / distal
Maxilla, lateral teeth,
mesial / distal
Maxilar superior,
región dientes laterales,
mesial / distal
Maxillaire, zone
des dents latérales,
mésial / distal
Mascella superiore,
settore dei denti laterali,
mesiali / distali



Ober- und Unterkiefer,
Frontzähne, universell
Maxilla and mandible,
incisors, universal
Ambos maxilares,
incisivos, universal
Mandibule et maxillaire,
incisives, universel
Mascella superiore e inferiore,
incisivi, universali

Langer
43-293-02 -
43-294-02

17,5 cm / 6 7/8"

Universalkürette
Universal curette
Cureta universal
Curette universelle
Curetta universale

Hohlgriff, 8 mm
hollow handle, 8 mm
mango hueco, 8 mm
poignée creuse, 8 mm
manico cavo, 8 mm



= grau
grey
gris
gris
grigio



= gelb
yellow
amarillo
jaune
giallo



= rot
red
rojo
rouge
rosso



= grün
green
verde
vert
verde



= violett
violet
violeta
violet
viola



= weiß
white
blanco
blanc
bianco



= blau
blue
azur
bleu
blu



= schwarz
black
negro
noir
nero

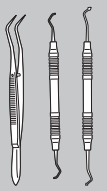

Roncati Scaler
43-800-00

17,5 cm / 6 7/8"

H6/H7

Scaler

Scaler

Limpiador

Tartre

Ablatore di tartaro

Hohlgriff, 10 mm

hollow handle, 10 mm

mango hueco, 10 mm

poignée creuse, 10 mm

manico cavo, 10 mm



Roncati
43-800-01

17,5 cm / 6 7/8"

Kürette, mikro, gerade

Curette, micro, straight

Cureta, micro, recto

Curette, micro, droit

Curetta, micro, diritto

Hohlgriff, 10 mm

hollow handle, 10 mm

mango hueco, 10 mm

poignée creuse, 10 mm

manico cavo, 10 mm



Roncati
43-800-02

17,5 cm / 6 7/8"

Kürette, mikro, gebogen

Curette, micro, curved

Cureta, micro, curva

Curette, micro, courbe

Curetta, micro, curva

Hohlgriff, 10 mm

hollow handle, 10 mm

mango hueco, 10 mm

poignée creuse, 10 mm

manico cavo, 10 mm

Warum Scaling-Instrumente immer scharf sein sollten:

1. Scharfe Instrumente bedeuten exaktes Arbeiten bei geringem Kraftaufwand.
2. Stumpfe Instrumente polieren den Zahnstein, quetschen das Weichgewebe und erfordern einen erhöhten Kraftaufwand.

Was benötigt man zum Schleifen von Instrumenten:

1. Schleifsteine (grob, fein und rund zum Entgraten)
2. Schleiföl (verhindert zu hohe Hitzeentwicklung, Erhaltung der Schleifwirkung des Schleifsteines)
3. Teststäbchen (aus Acryl zur Schärfeprüfung)
4. gutes Licht (scharfe Kanten reflektieren kein Licht)
5. Spannvorrichtung (z.B. Schraubstock)

Was ist nach dem Schleifen zu überprüfen:

1. abgerundete Rückenflächen
2. durchgängig scharfe Schneidkanten
3. einwandfreie Form des Arbeitsendes (z.B. Vergleich mit Katalogabbildung)
4. nach mehmaligem Aufschleifen des Instruments ist darauf zu achten, dass das Instrument noch stabil genug ist, um bei der anschließenden Behandlung nicht zu brechen. Sonst sollte das Instrument durch ein neues ersetzt werden.

Why scaling instruments should always be sharp:

1. Sharp instruments allow precision work with little application of force.
2. Blunt instruments polish the dental stone, bruise the soft tissue and require more application of force.

What you need for instrument sharpening:

1. Sharpening stones (rough, fine, and round for burr removal)
2. Sharpening oil (prevents excessive heat build-up; preserves the sharpening capacity of the sharpening stone)
3. Test stick (made of acrylic, for sharpness test)
4. Good light (sharp edges do not reflect light)
5. Clamping device (e.g. vise)

What to check after sharpening:

1. Roundness of back surfaces
2. Continuous sharpness of cutting edges
3. Perfect shape of working end (e.g. check against catalog illustration)
4. After several sharpening cycles, verify that the instrument is still strong enough for application. Replace instrument if necessary.

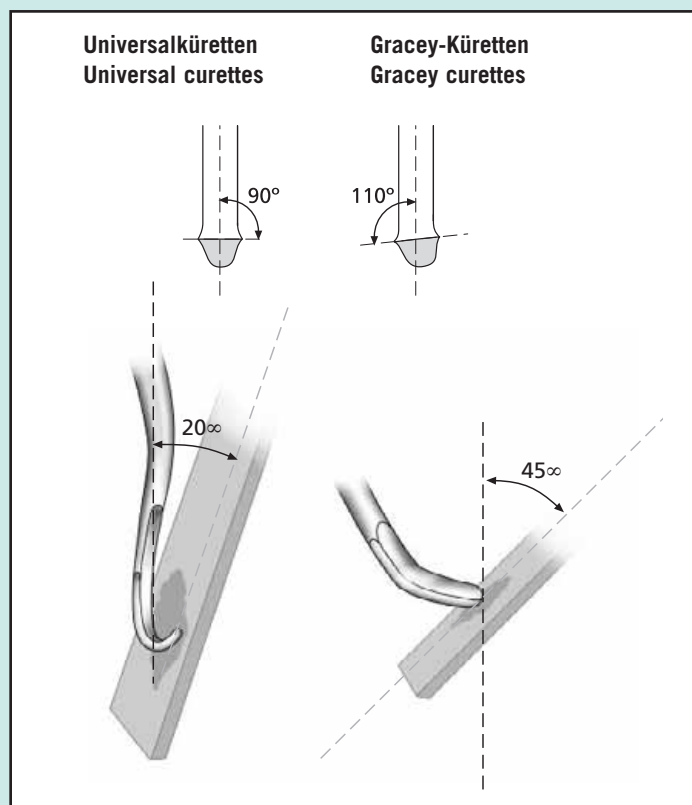
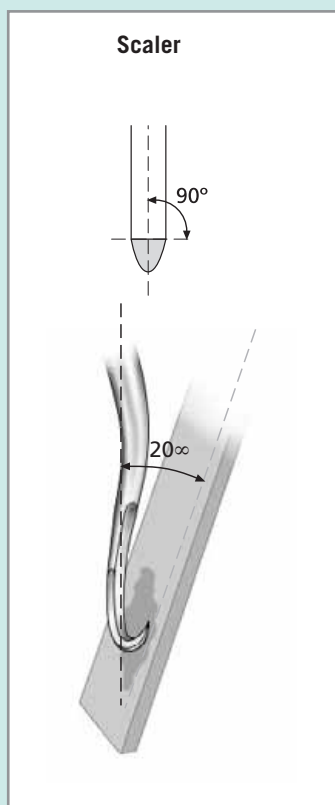

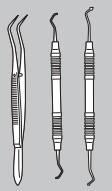

Farbkodierung von Scalern und Gracey-Küretten

1. Alle Scaler tragen eine grüne Farbkodierung – 3 Punkte verteilt auf den Durchmesser. Die Position der Farbkodierung kennzeichnet gleichzeitig das niedriger bezeichnete Arbeitsende.
2. Gracey Standard, Gracey Rigid und Gracey Mini Küretten tragen die Farbkodierung ebenfalls auf der Seite des niedriger bezeichneten Arbeitsendes, z.B. Gracey 1/2 = Farbkodierung auf der Seite von Arbeitsende Nr. 1.
3. Zur noch besseren Unterscheidung zwischen Gracey Standard und Gracey Mini auf der einen und Gracey Rigid auf der anderen Seite wurde bei den Gracey Rigid eine Farbkodierung mit sechs Farbpunkten gewählt.
4. Gracey Standard-Küretten mit Farbkodierung sind auch mit einem 10 mm-Griff erhältlich.

Color coding of scalers and Gracey curettes

1. All scalers are color-coded green – 3 points distributed across the diameter. At the same time, the color code marks the finer working end.
2. The Gracey Standard, Gracey Rigid and Gracey Mini curettes also have the color code on the side of the finer working end. Example: Gracey 1/2 = color code applied on side of working end no. 1.
3. For even better differentiation between Gracey Standard and Gracey Mini on the one hand and Gracey Rigid on the other hand, Gracey Rigid curettes are coded with six color points.
4. Color-coded Gracey Standard curettes are also available with a 10 mm handle.

43

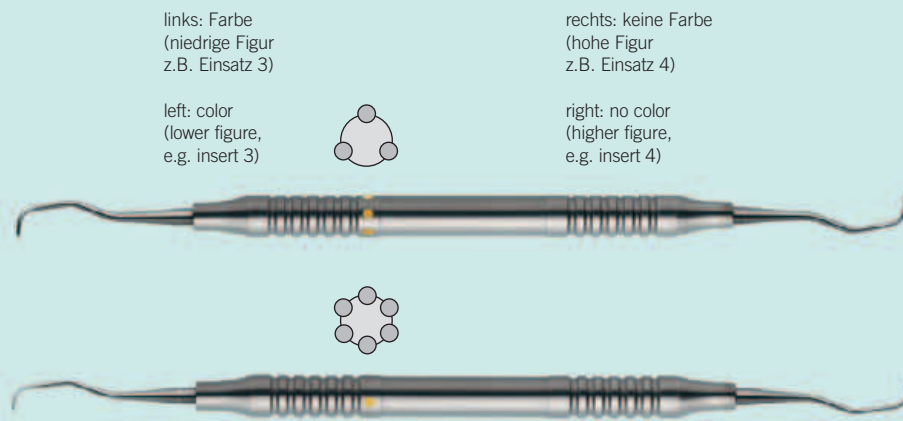

	∅		
Gracey Mini	8 mm	x	
Gracey Standard	8 mm	x	
Gracey Big	10 mm	x	
Gracey Rigid	8 mm		x

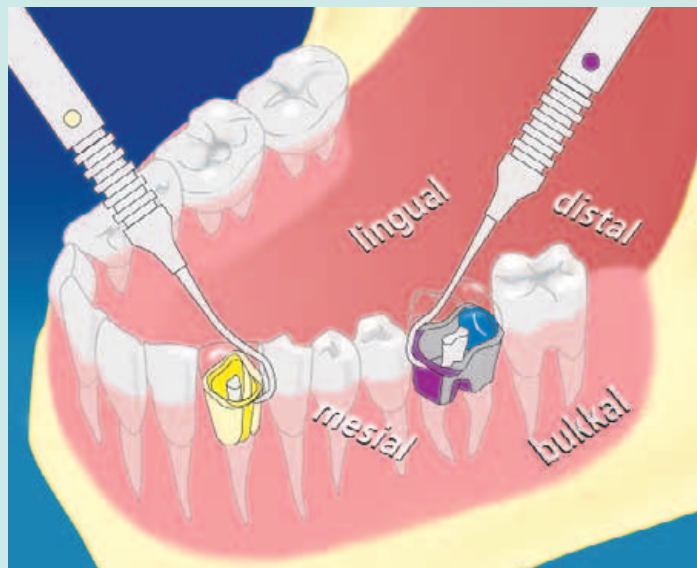

Anwendungsbereiche von Gracey-Küretten

Fields of application for Gracey curettes

- 1-2,3-4, 5-6 Frontzähne Incisors
- 7-8, 9-10 Prämolaren und Molaren (bukkal/lingual) Premolars and molars (buccal/lingual)
- 11-12, 15-16 Prämolaren und Molaren mesial, Furkation: mesialer Anteil der distalen Wurzel Premolars and molars, mesial Furcation: mesial portion of the distal root
- 13-14, 17-18 Prämolaren und Molaren distal, Furkation: distaler Anteil der mesialen Wurzel Premolars and molars, distal Furcation: distal portion of the mesial root

Gracey Mini-Küretten, subgingivaler Einsatz

Gracey mini curettes, subgingival

Gracey mini curetas, subgingival

Gracey mini curettes, subgingival

Gracey mini curette, subgingivale



1/4

Gracey Mini
43-336-02 -
43-336-08

17,5 cm / 6 7/8"

Hohlgriff, 8 mm
hollow handle, 8 mm
mango hueco, 8 mm
poignée creuse, 8 mm
manico cavo, 8 mm



43-336-02

Fig. 1/2

Frontzähne, universell,
längerer 1er Schaft,
kürzeres Arbeitsende
Incisors, universal,
first shaft longer, working
end shorter
Incisivos, universal,
vástago 1, más largo,
punta de trabajo más corta
Incisives, universel,
1ère tige plus longue,
extrémité opératoire plus
courte
Incisivi, universali,
1° stelo più lungo,
estremità di lavoro più breve

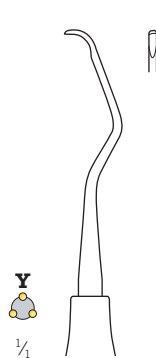

43-336-04

Fig. 3/4

Frontzähne, Prämolaren,
universell,
längerer 1er Schaft,
kürzeres Arbeitsende
Incisors, premolars,
universal,
first shaft longer,
working end shorter
Incisivos, premolares,
universal,
vástago 1, más largo,
punta de trabajo más corta
Incisives, universel,
1ère tige plus longue,
extrémité opératoire plus
courte
Incisivi, premolari,
universali,
1° stelo più lungo,
estremità di lavoro più breve

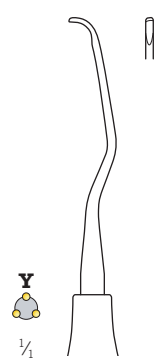

43-336-06

Fig. 5/6

Frontzähne, Prämolaren,
universell,
längerer 1er Schaft, kürzeres
Arbeitsende
Incisors, premolars,
universal,
first shaft longer,
working end shorter
Incisivos, premolares,
universal,
vástago 1, más largo,
punta de trabajo más corta
Incisives, universel,
1ère tige plus longue,
extrémité opératoire plus
courte
Incisivi, premolari,
universali,
1° stelo più lungo,
estremità di lavoro più breve

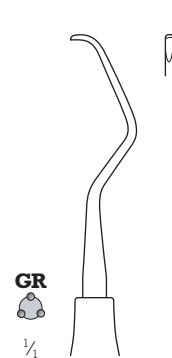

43-336-08

Fig. 7/8

Prämolaren, Molaren,
lingual/bukkal,
längerer 1er Schaft,
kürzeres Arbeitsende
Premolars, molars,
lingual/buccal,
first shaft longer, working
end shorter
Premolares, molares,
lingual/bucal, vástago 1,
más largo, punta de trabajo
más corta
Prémolaires, molaires,
lingual/buccal,
1ère tige plus longue,
extrémité opératoire plus
courte
Premolari, molari,
linguali/buccali,
1° stelo più lungo,
estremità di lavoro più breve

GR = grau
grey
gris
gris
grigio

Y = gelb
yellow
amarillo
jaune
giallo

R = rot
red
rojo
rouge
rosso

G = grün
green
verde
vert
verde

V = violett
violet
violeta
violet
viola

W = weiß
white
blanco
blanc
bianco

B = blau
blue
azur
blu

N = schwarz
black
negro
noir
nero

Gracey Mini-Küretten, subgingivaler Einsatz

Gracey mini curettes, subgingival
 Gracey mini curetas, subgingival
 Gracey mini curettes, subgingival
 Gracey mini curette, subgingivale

Reinigungsinstrumente

Scalers, periodontology
 Limpiadores de sarro, parodontología
 Instruments à détartrer, parodontologie
 Ablatori di tartaro, parodontologia

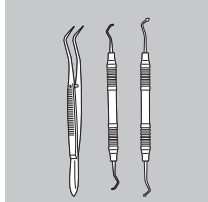

43



Gracey Mini
 43-336-10 -
 43-336-18
 17,5 cm / 6 7/8"
 Hohlgriff, 8 mm
 hollow handle, 8 mm
 mango hueco, 8 mm
 poignée creuse, 8 mm
 manico cavo, 8 mm

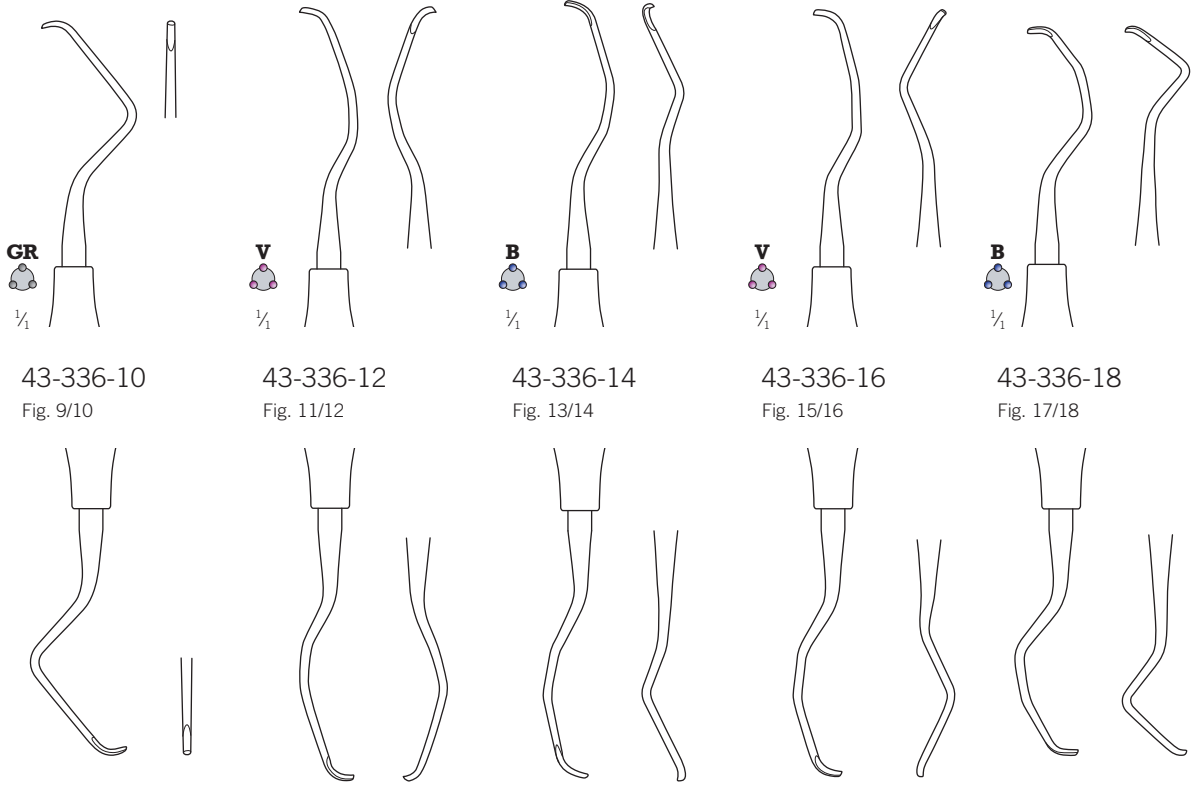

43-336-10 Fig. 9/10 43-336-12 Fig. 11/12 43-336-14 Fig. 13/14 43-336-16 Fig. 15/16 43-336-18 Fig. 17/18

<p>Prämolaren, Molaren, lingual/bukkal, längerer 1er Schaft, kürzeres Arbeitsende Premolars, molars, lingual/buccal, first shaft longer, working end shorter Premolares, molares, lingual/bucal, vástago 1, más largo, punta de trabajo más corta Prémolaires, molaires, lingual/buccal, 1ère tige plus longue, extrémité opératoire plus courte</p>	<p>Prämolaren, Molaren, mesial, mesiolingual, mesiobukkal, längerer 1er Schaft, kürzeres Arbeitsende Premolars, molars, mesial, mesiolingual, mesiobuccal, first shaft longer, working end shorter Premolares, molares, mesial, mesiolingual, mesiobucal, vástago 1, más largo, punta de trabajo más corta Prémolaires, molaires, mesial, mesiolingual, mesiobucal, 1ère tige plus longue, extrémité opératoire plus courte</p>	<p>Prämolaren, Molaren, distal, längerer 1er Schaft, kürzeres Arbeitsende Premolars, molars, distal, first shaft longer, working end shorter Premolares, molares, distal, vástago 1, más largo, punta de trabajo más corta Prémolaires, molaires, distal, 1ère tige plus longue, extrémité opératoire plus courte</p>	<p>Prämolaren, Molaren, mesial, längerer 1er Schaft, kürzeres Arbeitsende Premolars, molars, mesial, first shaft longer, working end shorter Premolares, molares, mesial, vástago 1, más largo, punta de trabajo más corta Prémolaires, molaires, mesial, 1ère tige plus longue, extrémité opératoire plus courte</p>	<p>Prämolaren, Molaren, distal, längerer 1er Schaft, kürzeres Arbeitsende Premolars, molars, distal, first shaft longer, working end shorter Premolares, molares, distal, vástago 1, más largo, punta de trabajo más corta Prémolaires, molaires, distal, 1ère tige plus longue, extrémité opératoire plus courte</p>
---	--	--	--	--

Gracey Standard-Küretten, subgingivaler Einsatz

Gracey standard curettes, subgingival

Gracey curetas estándar, subgingival

Gracey curettes standard, subgingival

Gracey curette standard, subgingivale



43-337-02

Fig. 1/2



Frontzähne, universell
Incisors, universal
Incisivos, universal
Incisives, universal
Incisivi, universali



43-337-04

Fig. 3/4



Frontzähne, Prämolaren,
universell
Incisors, premolars,
universal
Incisivos, premolares,
universal
Incisives, prémolaires,
universal
Incisivi, premolari,
universali

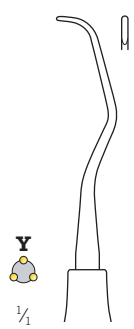

43-337-06

Fig. 5/6



Frontzähne, Prämolaren,
universell
Incisors, premolars,
universal
Incisivos, premolares,
universal
Incisives, prémolaires,
universal
Incisivi, premolari,
universali

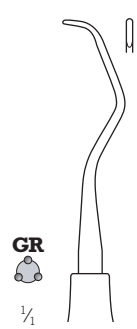

43-337-08

Fig. 7/8



Prämolaren, Molaren,
lingual / bukkal
Premolars, molars,
lingual / buccal
Premolares, molares,
lingual / bucal
Prémolaires, molaires,
lingual / buccal
Premolari, molari,
linguali / buccali

Gracey Standard
43-337-02 -
43-337-08

17,5 cm / 6 7/8"

Hohlgriff, 8 mm
hollow handle, 8 mm
mango hueco, 8 mm
poignée creuse, 8 mm
manico cavo, 8 mm

GR = grau
grey
gris
gris
grigio

Y = gelb
yellow
amarillo
jaune
giallo

R = rot
red
rojo
rouge
rosso

G = grün
green
verde
vert
verde

V = violett
violet
violeta
violet
viola

W = weiß
white
blanco
blanc
bianco

B = blau
blue
azur
bleu
blu

N = schwarz
black
negro
noir
nero

Gracey Standard-Küretten, subgingivaler Einsatz Reinigungsinstrumente

Gracey standard curettes, subgingival
 Gracey curetas estándar, subgingival
 Gracey curettes standard, subgingival
 Gracey curette standard, subgingivale

Scalers, periodontology
 Limpiadores de sarro, parodontología
 Instruments à détartrer, parodontologie
 Ablatori di tartaro, parodontologia

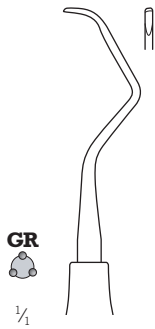
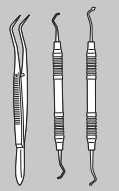

43-337-10
Fig. 9/10



Prämolaren, Molaren, lingual / bukkal
 Premolars, molars, lingual / buccal
 Premolares, molares, lingual / bucal
 Prémolaires, molaires, lingual / buccal
 Premolari, molari, linguali / buccali

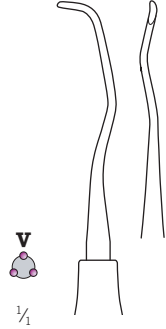

43-337-12
Fig. 11/12



Prämolaren, Molaren, mesial, mesiolingual, mesiobukkal
 Premolars, molars, mesial, mesiolingual, mesiobuccal
 Premolares, molares, mesial, mesiolingual, mesiobuccal
 Prémolaires, molaires, mésial, mésiolingual, mésiobuccal
 Premolari, molari, mesiali, mesiolinguali, mesiobuccali

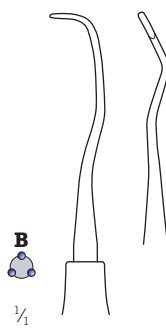

43-337-14
Fig. 13/14



Prämolaren, Molaren, distal
 Premolars, molars, distal
 Premolares, molares, distal
 Prémolaires, molaires, distal
 Premolari, molari, distali

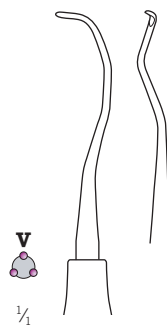

43-337-16
Fig. 15/16



Prämolaren, Molaren, mesial
 Premolars, molars, mesial
 Premolares, molares, mesial
 Prémolaires, molaires, mésial
 Premolari, molari, mesiali

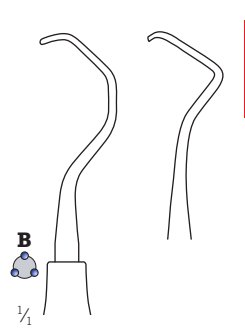

43-337-18
Fig. 17/18

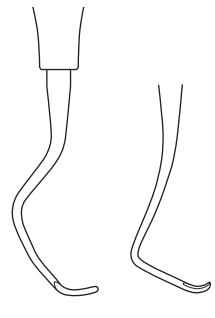

Prämolaren, Molaren, distal
 Premolars, molars, distal
 Premolares, molares, distal
 Prémolaires, molaires, distal
 Premolari, molari, distali

Gracey Standard 43-337-10 - 43-337-18

17,5 cm / 6 7/8"

Hohlgriff, 8 mm
 hollow handle, 8 mm
 mango hueco, 8 mm
 poignée creuse, 8 mm
 manico cavo, 8 mm

Gracey Rigid-Küretten, subgingivaler Einsatz

Gracey Rigid curettes, subgingival

Gracey Rigid curetas, subgingival

Gracey Rigid curettes, subgingival

Gracey Rigid curette, subgingivale



43-338-02
Fig. 1/2



Frontzähne, universell,
extra starr, für hartnäckige
Zahnbeläge
Incisors, universal,
extra rigid, for stubborn
dental plaque
Incisivos, universal,
extrarigido, para sarro
persistente
Incisives, universel,
extra rigide, pour tartes
tenaces
Incisivi, universali,
extrarigido, per placca
dentaria persistente



43-338-04
Fig. 3/4



Frontzähne, Prämolaren,
universell,
extra starr, für hartnäckige
Zahnbeläge
Incisors, premolars,
universal,
extra rigid, for stubborn
dental plaque
Incisivos, premolares,
universal,
extrarigido, para sarro
persistente
Incisives, prémolaires,
universal
extra rigide, pour tartes
tenaces
Incisivi, premolari, universali,
extrarigido, per placca
dentaria persistente



43-338-06
Fig. 5/6



Frontzähne, Prämolaren,
universell,
extra starr, für hartnäckige
Zahnbeläge
Incisors, premolars,
universal,
extra rigid, for stubborn
dental plaque
Incisivos, premolares,
universal,
extrarigido, para sarro
persistente
Incisives, prémolaires,
universal,
extra rigide, pour tartes
tenaces
Incisivi, premolari, universali,
extrarigido, per placca
dentaria persistente

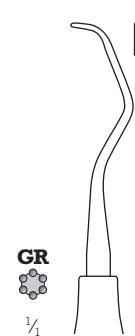

43-338-08
Fig. 7/8



Prämolaren, Molaren,
lingual, bukkal,
extra starr, für hartnäckige
Zahnbeläge
Premolars, molars, lingual,
buccal,
extra rigid, for stubborn
dental plaque
Premolares, molares, lingual,
bucal,
extrarigido, para sarro
persistente
Prémolaires, molaires,
lingual, buccal,
extra rigide, pour tartes
tenaces
Premolari, molari, linguali,
buccali,
extrarigido, per placca
dentaria persistente

Gracey Rigid
43-338-02 -
43-338-08

17,5 cm / 6 7/8"

Hohlgriff, 8 mm
hollow handle, 8 mm
mango hueco, 8 mm
poignée creuse, 8 mm
manico cavo, 8 mm

GR = grau
grey
gris
gris
grigio

Y = gelb
yellow
amarillo
jaune
giallo

R = rot
red
rojo
rouge
rosso

G = grün
green
verde
vert
verde

V = violett
violet
violeta
violet
viola

W = weiß
white
blanco
blanc
bianco

B = blau
blue
azur
blanc
blu

N = schwarz
black
negro
noir
nero

Gracey Rigid-Küretten, subgingivaler Einsatz

Gracey Rigid curettes, subgingival
 Gracey Rigid curetas, subgingival
 Gracey Rigid curettes, subgingival
 Gracey Rigid curette, subgingivale

Reinigungsinstrumente

Scalers, periodontology
 Limpiadores de sarro, parodontología
 Instruments à détartrer, parodontologie
 Ablatori di tartaro, parodontologia

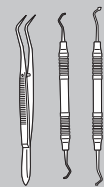

43



Gracey Rigid
 43-338-10 -
 43-338-18
 17,5 cm / 6 7/8"
 Hohlgriff, 8 mm
 hollow handle, 8 mm
 mango hueco, 8 mm
 poignée creuse, 8 mm
 manico cavo, 8 mm

 GR 1/4	 V 1/4	 B 1/4	 V 1/4	 B 1/4
43-338-10 Fig. 9/10	43-338-12 Fig. 11/12	43-338-14 Fig. 13/14	43-338-16 Fig. 15/16	43-338-18 Fig. 17/18
Prämolaren, Molaren, lingual, bukkal, extra starr, für hartnäckige Zahnbeläge Premolars, molars, lingual, buccal, extra rigid, for stubborn dental plaque Premolares, molares, lingual, bucal, extrarígido, para sarro persistente Prémolaires, molaires, lingual, buccal, extra rigide, pour tartes tenaces Premolari, molari, linguali, buccali, extrarígido, per placca dentaria persistente	Prämolaren, Molaren, mesial, mesiolingual, mesiobukkal extra starr, für hartnäckige Zahnbeläge Premolars, molars, mesial, mesiolingual, mesiobuccal, extra rigid, for stubborn dental plaque Premolares, molares, mesial, mesiolingual, mesiobuccal, extrarígido, para sarro persistente Prémolaires, molaires, mésial, mésiolingual, mesiobuccal, extra rigide, pour tartes tenaces Prémolaires, molaires, mésial, mésiolingual, mesiobuccal, extra rigide, pour tartes tenaces Premolari, molari, mesiali, mesiolinguali, mesiobuccali, extrarígido, per placca dentaria persistente	Prämolaren, Molaren, distal extra starr, für hartnäckige Zahnbeläge Premolars, molars, distal extra rigid, for stubborn dental plaque Premolares, molares, distal, extrarígido, para sarro persistente Prémolaires, molaires, distal, extra rigide, pour tartes tenaces Premolari, molari, distali, extrarígido, per placca dentaria persistente	Prämolaren, Molaren, mesial, extra starr, für hartnäckige Zahnbeläge Premolars, molars, mesial, extra rigid, for stubborn dental plaque Premolares, molares, mesial, extrarígido, para sarro persistente Prémolaires, molaires, mésial, extra rigide, pour tartes tenaces Premolari, molari, mesiali, extrarígido, per placca dentaria persistente	Prämolaren, Molaren, distal extra starr, für hartnäckige Zahnbeläge Premolars, molars, distal extra rigid, for stubborn dental plaque Premolares, molares, distal, extrarígido, para sarro persistente Prémolaires, molaires, distal, extra rigide, pour tartes tenaces Premolari, molari, distali, extrarígido, per placca dentaria persistente

Gracey Küretten mit 10 mm-Griff

Gracey curettes with 10 mm handle
 Gracey curetas para mangos 10 mm
 Gracey curettes avec manches à 10 mm
 Cracey curette con manici 10 mm



43-339-02
Fig. 1/2



Frontzähne, universell
 Incisors, universal
 Incisivos, universal
 Incisives, universel
 Incisivi, universali

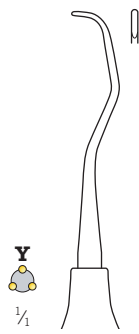

43-339-04
Fig. 3/4



Frontzähne, Prämolaren,
 universell
 Incisors, premolars, universal
 Incisivos, premolares,
 universal
 Incisives, prémolaires,
 universel
 Incisivi, premolari, universali



43-339-06
Fig. 5/6



Frontzähne, Prämolaren,
 universell
 Incisors, premolars, universal
 Incisivos, premolares,
 universal
 Incisives, prémolaires,
 universel
 Incisivi, premolari, universali



43-339-08
Fig. 7/8



Prämolaren, Molaren,
 lingual, bukkal
 Premolars, molars, lingual,
 buccal
 Premolares, molares, lingual,
 bucal
 Prémolaires, molaires,
 lingual, buccal
 Premolari, molari, linguale,
 buccali

1/4

Big Gracey
 43-339-02 -
 43-339-08

17,5 cm / 6 7/8"

Hohlgriff, 10 mm
 hollow handle, 10 mm
 mango hueco, 10 mm
 poignée creuse, 10 mm
 manico cavo, 10 mm

GR = grau
 grey
 gris
 gris
 grigio

Y = gelb
 yellow
 amarillo
 jaune
 giallo

R = rot
 red
 rojo
 rouge
 rosso

G = grün
 green
 verde
 vert
 verde

V = violett
 violet
 violeta
 violet
 viola

W = weiß
 white
 blanco
 blanc
 bianco

B = blau
 blue
 azur
 bleu
 blu

N = schwarz
 black
 negro
 noir
 nero

Gracey Küretten mit 10 mm-Griff

Gracey curettes with 10 mm handle
 Gracey curetas para mangos 10 mm
 Gracey curettes avec manches à 10 mm
 Gracey curette con manici 10 mm

Reinigungsinstrumente

Scalers, periodontology
 Limpiadores de sarro, parodontología
 Instruments à détartrer, parodontologie
 Ablatori di tartaro, parodontologia

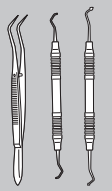

43

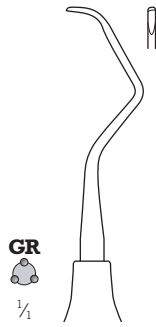

43-339-10
Fig. 9/10

Prämolaren, Molaren, lingual, bukkal
 Premolars, molars, lingual, buccal
 Premolares, molares, lingual, bucal
 Prémolaires, molaires, lingual, buccal
 Premolari, molari, linguali, buccali

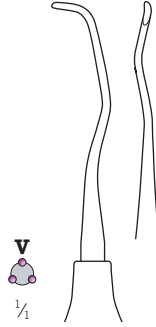

43-339-12
Fig. 11/12

Prämolaren, Molaren, mesial, mesiolingual, mesiobukkal
 Premolars, molars, mesial, mesiolingual, mesiobuccal
 Premolares, molares, mesial, mesiolingual, mesiobuccal
 Prémolaires, molaires, mésial, mésiolingual, mésiobuccal
 Premolari, molari, mesiali, mesiolinguali, mesiobuccali

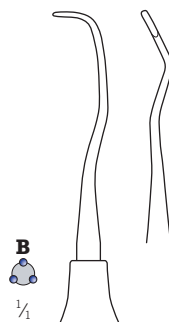

43-339-14
Fig. 13/14

Prämolaren, Molaren, distal
 Premolars, molars, distal
 Premolares, molares, distal
 Prémolaires, molaires, distal
 Premolari, molari, distali

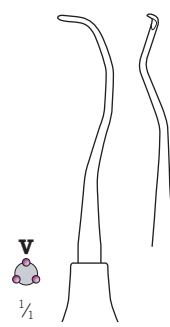

43-339-16
Fig. 15/16

Prämolaren, Molaren, mesial
 Premolars, molars, mesial
 Premolares, molares, mesial
 Prémolaires, molaires, mésial
 Premolari, molari, mesiali

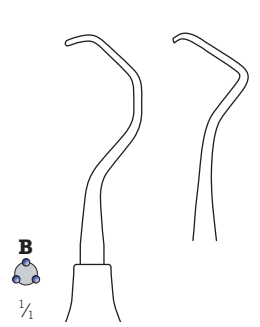

43-339-18
Fig. 17/18

Prämolaren, Molaren, distal
 Premolars, molars, distal
 Premolares, molares, distal
 Prémolaires, molaires, distal
 Premolarim molari, distali

Big Gracey 43-339-10 - 43-339-18

17,5 cm / 6 7/8"

Hohlgriff, 10 mm
 hollow handle, 10 mm
 mango hueco, 10 mm
 poignée creuse, 10 mm
 manico cavo, 10 mm

Küretten, subgingivaler Einsatz

Curettes, subgingival

Curetas, subgingival

Curettes, subgingival

Curette, subgingivale

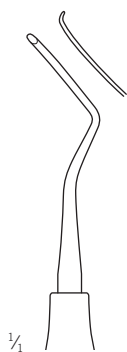

43-350-01
Fig. 1



43-350-02
Fig. 2



43-350-03
Fig. 3

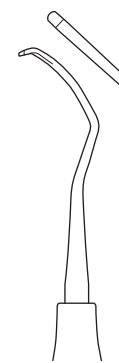

43-350-04
Fig. 4



Furkationskürette
Furcation curette
Cureta de furcación
Curette à furcation
Curetta di forcazione
0,9 mm
bukkal / lingual
buccal / lingual
buccal / lingual
buccal / lingual
buccali / linguali

Furkationskürette
Furcation curette
Cureta de furcación
Curette à furcation
Curetta di forcazione
3 mm
bukkal / lingual
buccal / lingual
buccal / lingual
buccal / lingual
buccali / linguali

Furkationskürette
Furcation curette
Cureta de furcación
Curette à furcation
Curetta di forcazione
0,9 mm
mesial / distal
mesial / distal
mesial / distal
mesial / distal
mesiali / distali

Furkationskürette
Furcation curette
Cureta de furcación
Curette à furcation
Curetta di forcazione
1,3 mm
mesial / distal
mesial / distal
mesial / distal
mesial / distal
mesiali / distali

43-350-01 -
43-350-04

17,5 cm / 6 7/8"

Hohlgriff, 8 mm
hollow handle, 8 mm
mango hueco, 8 mm
poignée creuse, 8 mm
manico cavo, 8 mm

Küretten, subgingivaler Einsatz

Curettes, subgingival
Curetas, subgingival
Curettes, subgingival
Curette, subgingivale

Reinigungsinstrumente

Scalers, periodontology
Limpiadores de sarro, parodontología
Instruments à détartrer, parodontologie
Ablatori di tartaro, parodontologia

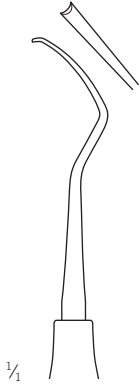
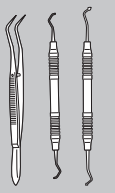

43-350-05
Fig. 5

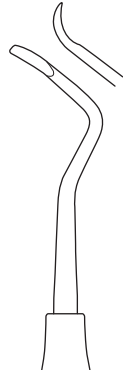

Prichard
43-364-01
Fig. 1/2



43

Furkationskürette
Furcation curette
Cureta de furcación
Curette à furcation
Curetta di forcazione

0,9 mm
labial / lingual
labial / lingual
labial / lingual
labiale / lingual
labiali / linguali

Chirurgische Kürette,
extra lange, kräftige
Konstruktion,
zweischneidig

Bone curette,
extra long, robust
construction, double
cutting

Cureta para hueso,
construcción robusta
extralarga, doble
cortante

Curette à os,
construction très
longue, robuste,
double coupe

Curetta ossea,
design extralungo,
robusto, doppio
taglio

Gracey Mini-Küretten, subgingivaler Einsatz

Gracey mini curettes, subgingival

Gracey mini curetas, subgingival

Gracey mini curettes, subgingival

Gracey mini curette, subgingivale

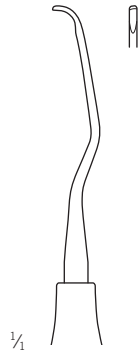

Frontzähne, Prämolaren,
universell,
längerer 1er Schaft,
kürzeres Arbeitsende

Incisors, premolars,
universal,
first shaft longer,
working end shorter

Incisivos, premolares,
universal,
vástago 1, más largo,
punta de trabajo más corta

Incisives, universal,
1ère tige plus longue,
extrémité opératoire plus
courte

Incisivi, premolari,
universali,
1° stelo più lungo,
estremità di lavoro più breve

1/4

43-334-06

Ti

Fig. 5/6

17,5 cm / 6 7/8"

Hohlgriff, 10 mm
hollow handle, 10 mm
mango hueco, 10 mm
poignée creuse, 10 mm
manico cavo, 10 mm



Ti

Griff, Titan
Handle, Titane
Mango, Titane
Poignée, Titane
Manico, Titane

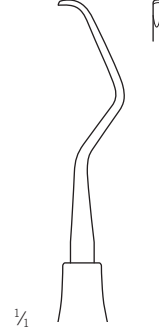

Prämolaren, Molaren,
lingual/bukkal,
längerer 1er Schaft,
kürzeres Arbeitsende

Premolars, molars,
lingual/buccal,
first shaft longer,
working end shorter

Premolares, molares,
lingual/bucal, vástago 1,
más largo, punta de trabajo
más corta

Prémolaires, molaires,
lingual/bucal,
1ère tige plus longue,
extrémité opératoire plus
courte

Premolari, molari,
linguali/buccali,
1° stelo più lungo,
estremità di lavoro più breve

1/4

43-334-08

Ti

Fig. 7/8

17,5 cm / 6 7/8"

Hohlgriff, 10 mm
hollow handle, 10 mm
mango hueco, 10 mm
poignée creuse, 10 mm
manico cavo, 10 mm

Gracey Mini-Küretten, subgingivaler Einsatz

Gracey mini curettes, subgingival
 Gracey mini curetas, subgingival
 Gracey mini curettes, subgingival
 Gracey mini curette, subgingivale

Reinigungsinstrumente

Scalers, periodontology
 Limpiadores de sarro, parodontología
 Instruments à détartrer, parodontologie
 Ablatori di tartaro, parodontologia

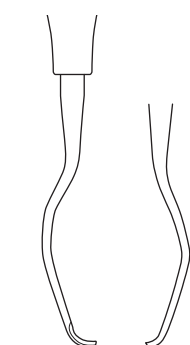
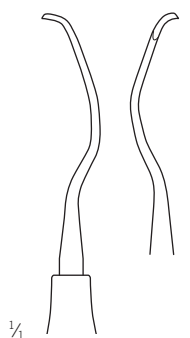
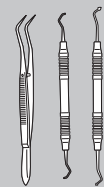

Prämolaren, Molaren, mesial, mesiolingual, mesiobukkal, längerer 1er Schaft, kürzeres Arbeitsende
 Premolars, molars, mesial, mesiolingual, mesiobuccal, first shaft longer, working end shorter
 Premolares, molares, mesial, mesiolingual, mesiobucal, vástago 1, más largo, punta de trabajo más corta

Prémolaires, molaires, mésial, mésiolingual, mésiobuccal, 1ère tige plus longue, extrémité opératoire plus courte
 Premolari, molari, mesiali, mesiolinguali, mesiobuccali, 1° stelo più lungo, estremità di lavoro più breve

1/4

43-334-12

Ti

Fig. 11/12

17,5 cm / 6 7/8"

Hohlgriff, 10 mm
 hollow handle, 10 mm
 mango hueco, 10 mm
 poignée creuse, 10 mm
 manico cavo, 10 mm



Ti

Griff, Titan
 Handle, Titane
 Mango, Titane
 Poignée, Titane
 Manico, Titane



Prämolaren, Molaren, distal, längerer 1er Schaft, kürzeres Arbeitsende

Premolars, molars, distal, first shaft longer, working end shorter

Premolares, molares, distal, vástago 1, más largo, punta de trabajo más corta

Prémolaires, molaires, distal, 1ère tige plus longue, extrémité opératoire plus courte

Premolari, molari, distali, 1° stelo più lungo, estremità di lavoro più breve

1/4

43-334-14

Ti

Fig. 13/14

17,5 cm / 6 7/8"

Hohlgriff, 10 mm
 hollow handle, 10 mm
 mango hueco, 10 mm
 poignée creuse, 10 mm
 manico cavo, 10 mm

Gracey Standard-Küretten, subgingivaler Einsatz

Gracey standard curettes, subgingival

Gracey curetas estándar, subgingival

Gracey curettes standard, subgingival

Gracey curette standard, subgingivale



Frontzähne, Prämolaren,
universell
Incisors, premolars, universal
Incisivos, premolares,
universal
Incisives, prémolaires,
universel
Incisivi, premolari, universali

1/4

43-335-06 Ti

Fig. 5/6

17,5 cm / 6 7/8"

Hohlgriff, 10 mm
hollow handle, 10 mm
mango hueco, 10 mm
poignée creuse, 10 mm
manico cavo, 10 mm



Prämolaren, Molaren,
lingual / bukkal
Premolars, molars,
lingual / buccal
Prémolaires, molaires,
lingual / bucal
Prémolaires, molaires,
lingual / buccal
Premolari, molari,
linguali / buccali

1/4

43-335-08 Ti

Fig. 7/8

17,5 cm / 6 7/8"

Hohlgriff, 10 mm
hollow handle, 10 mm
mango hueco, 10 mm
poignée creuse, 10 mm
manico cavo, 10 mm



Ti

Griff, Titan
Handle, Titane
Mango, Titane
Poignée, Titane
Manico, Titane

Gracey Standard-Küretten, subgingivaler Einsatz Reinigungsinstrumente

Gracey standard curettes, subgingival
 Gracey curetas estándar, subgingival
 Gracey curettes standard, subgingival
 Gracey curette standard, subgingivale

Scalers, periodontology
 Limpiadores de sarro, parodontología
 Instruments à détartrer, parodontologie
 Ablatori di tartaro, parodontologia

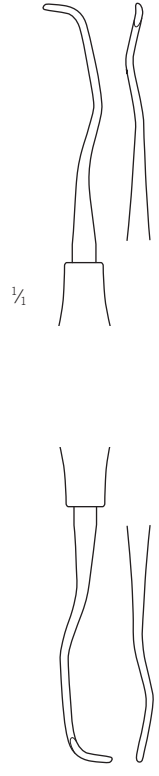
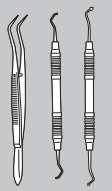

Prämolaren, Molaren, mesial,
 mesiolingual, mesiobukkal
 Premolars, molars, mesial,
 mesiolingual, mesiobuccal
 Premolares, molares, mesial,
 mesiolingual, mesiobucal
 Prémolaires, molaires, mésial,
 mesiolingual, mésiobuccal
 Premolari, molari, mesiali,
 mesiolinguali, mesiobuccali

1/1

43-335-12 Ti

Fig. 11/12
 17,5 cm / 6 7/8"
 Hohlgriff, 10 mm
 hollow handle, 10 mm
 mango hueco, 10 mm
 poignée creuse, 10 mm
 manico cavo, 10 mm

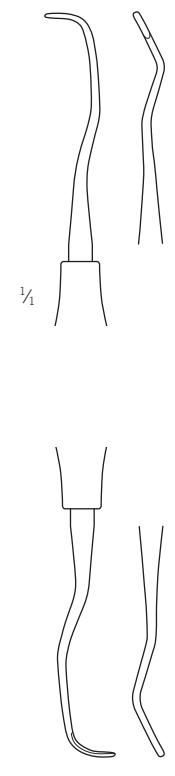

Prämolaren, Molaren, distal
 Premolars, molars, distal
 Premolares, molares, distal
 Prémolaires, molaires, distal
 Premolari, molari, distali

1/1

43-335-14 Ti

Fig. 13/14
 17,5 cm / 6 7/8"
 Hohlgriff, 10 mm
 hollow handle, 10 mm
 mango hueco, 10 mm
 poignée creuse, 10 mm
 manico cavo, 10 mm



Ti
 Griff, Titan
 Handle, Titane
 Mango, Titane
 Poignée, Titane
 Manico, Titane

Schleifsteine

Sharpening stones

Piedras de afilar

Meules

Pietre per affilare



Record Arkansas 43-840-00

115 x 40 x 10/2 mm

Multiform, weiß
multi shape, white
forma múltiple, blanco
multiforme, blanc
multiforme, bianco

Zum Vorschleifen stumpfer Instrumente.
Mit abgerundeten Kanten und abgeschrägten
Flächen für Radien und Flächen

For pregrinding of blunt instruments. The
rounded edges and bevelled surfaces enable
the sharpening of radius and surfaces

Para preafilar instrumentos romos. Los cantos
redondeados y las superficies biseladas
permiten afilar radios y superficies

Pour le dégrossissage d'instruments émoussés.
Avec bords arrondies et surfaces en biseau
pour rayons et surfaces

Per la sgrossatura degli strumenti smussati.
Con bordi arrotondati e superfici smussate
consentono di affilare radi e superfici



Original Arkansas 43-840-01

100 x 25 x 7 mm

flach, grau-weiß
flat, grey-white
plano, blanco-gris
plat, blanc-gris
piatto, bianco-grigio

Zum wiederholten Aufschleifen sowie Finieren von Scalern
und Küretten

For repeated grinding and finishing of scalers and
curettes

Para el afilado continuo y acabado de limpiadores y
curettes

Pour le polissage répété ainsi que la finition
d'instruments pour enlever la tartre et curettes

Per una ripetuta molatura e finitura di ablatori di tartaro e
curette



Original Arkansas 43-840-02

100 mm lang, Ø 8 mm

rund, grau-weiß
round, grey-white
redondo, blanco-gris
rond, blanc-gris
rotondo, bianco-grigio

Zum Entgraten der Federkanten
For burr removing from cutting edges

Para quitar la rebaba de los filos

Pour l'ébarbage des bords

Per la sbavatura dei bordi



India-Korund 43-840-05

115 x 45 x 2 - 10 mm

fein, braun-beige
delicate, brown-beige
delicado, marrón-beige
fin, brun-beige
fine, beige-marrone

Zum Vorschleifen von sehr stumpfen Instrumenten
For sharpening and recontouring of very blunt
instruments

Para preafilar y volverles a dar forma a instrumentos

Pour le dégrossissage d'instruments émoussés

Per la sgrossatura di strumenti molto smussati



India-Korund 43-840-06

100 mm lang, Ø 5 - 10 mm

rund, fein, braun-beige
round, delicate, brown-beige
redondo, delicado, marrón-beige
rond, fin, brun-beige
rotondo, file, beige-marrone

Zum Entgraten von Federkanten

For burr removing from cutting edges

Para quitar la rebaba de los filos

Pour l'ébarbage des bords

Per la sbavatura dei bordi



43-840-08

75 mm lang, Ø 7 mm

Teststäbchen aus Kunststoff
Test stick plastic
Varita de prueba de plástico
Bâtonnets pour test en plastique
Asta per test in plastica

Verpackungseinheit 6 Stück
package of 6 pieces
embalaje de 6 piezas
unité de commande 6 pièces
confezione da 6 pezzi

Zur Kontrolle der Schneidwirkung von Scalern und
Küretten

For testing the sharpness of scalers and curettes

Para probar el filo de limpiadores y curetas

Pour le contrôle de l'effet de coupe d'instruments

pour enlever le tartre et de curettes

Per il controllo dell'effetto di taglio di ablatori di
tartaro e curette

Schleifsteine

Sharpening stones

Piedras de afilar

Meules

Pietre per affilare

Reinigungsinstrumente

Scalers, periodontology

Limpiadores de sarro, parodontología

Instruments à détartrer, parodontologie

Ablatori di tartaro, parodontologia



43



Record Arkansas 10-875-00

150 x 50 mm

im Holzkasten

in wooden case

en estuche de madera

en conteneur en bois

in contenitori di legno



43-840-09

Schleifsteinöl

Sharpening stone oil

Aceite para piedras de afilar

Huile à pierre à aiguiser

Olio per pietra abrasiva

Parodontometer

Periodontal probes
 Sondas parodontales
 Sondes parodontales
 Sonde parodontali

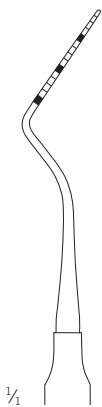

43-300-01



Iglhaut
 43-300-01 
 17,5 cm / 6 7/8"
 massiver Griff, 6 mm,
 solid handle, 6 mm
 mango sólido, 6 mm
 poignée massive, 6 mm
 solida impugnatura, 6 mm

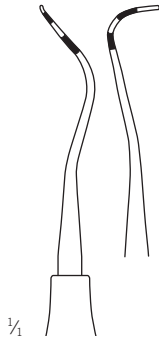

43-347-40



Furkationssonde,
 graduiertes Arbeits-ende
 Furcation probe,
 graduated working end
 Sonda de furcación,
 punta de trabajo graduada
 Sonde de furcation,
 extrémité opératoire graduée
 Sonda di forcazione,
 estremità di lavoro graduata

Nabers
 43-347-40
 17,5 cm / 6 7/8"
 Hohlgriff, 8 mm
 hollow handle, 8 mm
 mango hueco, 8 mm
 poignée creuse, 8 mm
 manico cavo, 8mm



43-356-08
 Fig. 8
 Grad. 3-6-8-11



43-356-10
 Fig. 10
 Grad. 1-2-3-5-7-8-9-10



43-356-11
 Fig. 11
 Grad. 3-6-8-11



43-357-00
 Fig. W
 Grad. 1-2-3-5-7-8-9-10

43-356-08 - 43-357-00
 16 cm / 6 1/8"
 massiver Griff, 6 mm,
 solid handle, 6 mm
 mango sólido, 6 mm
 poignée massive, 6 mm
 solida impugnatura, 6 mm

Parodontometer-Ansatz

Periodontal probes, interchangeable
 Sondas parodontales, intercambiables
 Sondes parodontales, interchangeables
 Sonde parodontali, intercambiabili

Reinigungsinstrumente

Scalers, periodontology
 Limpiadores de sarro, parodontología
 Instruments à détartrer, parodontologie
 Ablatori di tartaro, parodontologia

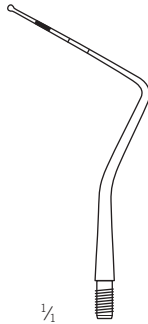
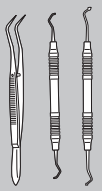

St
Ti

43-734-11

43-734-13

43-734-21

43-734-23

43-735-11

43-735-13

43-735-21

43-735-23

Fig. CPG 11,5 WHO
 Grad. 3,5-5,5-8,5-11,5

Fig. CPG 12
 Grad. 3-6-9-12

Fig. CP 15 UNC
 Grad. 1-2-3-4-...-14-15

Fig. CPNG 22
 Grad. 2-4-6-8-10-12

mit Kugel
 with ball
 con bola
 avec bille
 con sfera



Nabers
 43-347-40

17,5 cm / 6 7/8"

Hohlgriff, 8 mm
 hollow handle, 8 mm
 mango hueco, 8 mm
 poignée creuse, 8 mm
 manico cavo, 8mm

Sondengriffe siehe Seite 290
 Probe handles see page 290
 Mangos endosondas miren página 290
 Poignées endosondes voir page 290
 Impugnatori endosonde vedi pagina 290

Parodontometer

Periodontal probes
 Sondas parodontales
 Sondes parodontales
 Sonde parodontali



43-736-00 -
 43-736-26

17,5 cm / 6 7/8"

massiver Griff, 6 mm,
 solid handle, 6 mm
 mango sólido, 6 mm
 poignée massive, 6 mm
 solida impugnatura, 6 mm

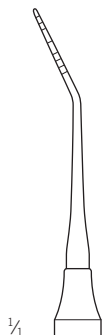

1/4

Merrit A
 43-736-00

Grad. 1-2-3-5-7-8-9-10

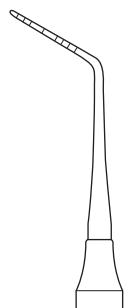

Merrit E
 43-736-01

Grad. 1-2-3-5-7-8-9-10



Goldman-Fox
 43-736-04

Grad. 1-2-3-5-7-8-9-10



Michigan
 43-736-06

Grad. 3-6-8



1/4

Mercury
 43-736-08

Grad. 3-6-9-12



mit Kugel
 with ball
 con bola
 avec bille
 con sfera

43-736-10

Fig. CPNG 12S

Grad. 3-6-9-12



mit Kugel
 with ball
 con bola
 avec bille
 con sfera

WHO
 43-736-11

Fig. CPG 11,5 WHO

Grad. 3,5-5,5-8,5-11,5



43-736-12

Fig. CPG 12

Grad. 3-6-9-12



1/4

43-736-15

Fig. CP 15 UNC

Grad. 1-2-3-4-5 ... 14-15



43-736-22

Fig. CPNG 22

Grad. 2-4-6-8-10-12



43-736-26

Fig. 26G

Grad. 1-2-3-5-7-8-9-10

Parodontometer

Periodontal probes
 Sondas parodontales
 Sondes parodontales
 Sonde parodontali

Reinigungsinstrumente

Scalers, periodontology
 Limpiadores de sarro, parodontología
 Instruments à détartrer, parodontologie
 Ablatori di tartaro, parodontologia

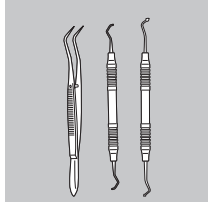

Williams-Goldman-Fox
 43-738-02
 Grad. 1-2-3-5-7-8-9-10

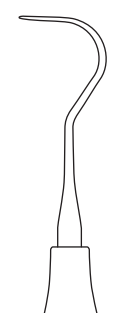

43-738-04
 Fig. CP 11/23
 Grad. 3-6-8-11



43-738-06
 Fig. CP 12/23
 Grad. 3-6-9-12

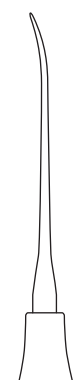

43-738-08
 Fig. GF/3
 Grad. 1-2-3-5-7-8-9-10

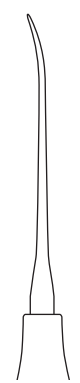

43-738-10
 Fig. UM/3
 Grad. 3-6-8

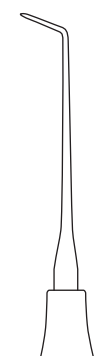
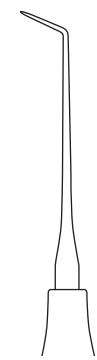
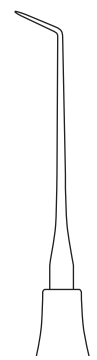
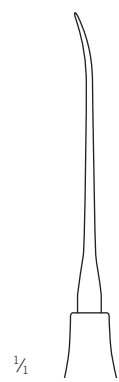

43-738-02 -
 43-738-20
 17,5 cm / 6 7/8"
 Hohlgriff , 8 mm
 hollow handle, 8 mm
 mango hueco, 8 mm
 poignée creuse, 8 mm
 manico cavo, 8mm

43-738-12
 Fig. W/3
 Grad. 1-2-3-5-7-8-9-10

43-738-14
 Fig. GF/6
 Grad. 1-2-3-5-7-8-9-10

43-738-16
 Fig. UM/6
 Grad. 3-6-8

43-738-18
 Fig. W/6
 Grad. 1-2-3-5-7-8-9-10

43-738-20
 Fig. GF/17
 Grad. 1-2-3-5-7-8-9-10



Parodontometer

Periodontal probes
Sondas parodontales
Sondes parodontales
Sonde parodontali



43-738-22
Fig. UM/17
Grad. 3-6-8



43-738-24
Fig. W/17
Grad. 1-2-3-5-7-8-9-10

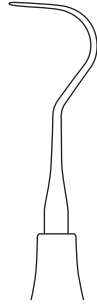

43-738-26
Fig. GF/23
Grad. 1-2-3-5-7-8-9-10

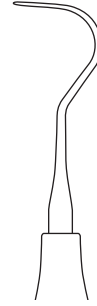

43-738-28
Fig. UM/23
Grad. 3-6-8

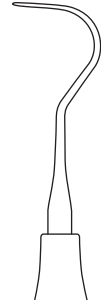

43-738-30
Fig. W/23
Grad. 1-2-3-5-7-8-9-10



43-738-22 -
43-738-30

17,5 cm / 6 7/8"

Hohlgriff, 8 mm
hollow handle, 8 mm
mango hueco, 8 mm
poignée creuse, 8 mm
manico cavo, 8 mm

Zahnsonden

Explorers
Sondas
Sondes
Sonde

Reinigungsinstrumente

Scalers, periodontology
Limpiadores de sarro, parodontología
Instruments à détartrer, parodontologie
Ablatori di tartaro, parodontologia

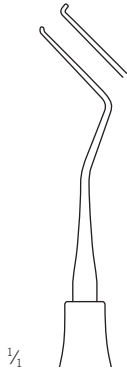
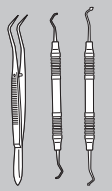

1/4



1/4

Cross
43-348-10

17,5 cm / 6 7/8"

Hohlgriff, 8 mm
hollow handle, 8 mm
mango hueco, 8 mm
poignée creuse, 8 mm
manico cavo, 8 mm

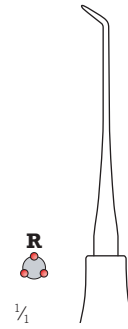

1/4



1/4

Zürich
43-400-02

17,5 cm / 6 7/8"

Hohlgriff, 8 mm
hollow handle, 8 mm
mango hueco, 8 mm
poignée creuse, 8 mm
manico cavo, 8 mm

Mikro-Sonde, zum Ertasten des Wurzelkanals von retrograd nach WSR

Micro probe, for retrograde detection of root canal following apicoectomy

Micro sonda, para la detección retrógrada del canal radicular después de la apicectomía

Micro sonde, pour la détection rétrograde du canal de la racine après résection de l'apex

Micro sonda, per la rilevazione retrograda del canale della radice in seguito a interventi di apicectomia

GR = grau
grey
gris
gris
grigio

Y = gelb
yellow
amarillo
jaune
giallo

R = rot
red
rojo
rouge
rosso

G = grün
green
verde
vert
verde

V = violett
violet
violeta
violet
viola

W = weiß
white
blanco
blanc
bianco

B = blau
blue
azur
bleu
blu

C = hellblau
light-blue
azul claro
bleu clair
azzurro

Zahnsonden

Explorers
Sondas
Sondes
Sonde

finoLine

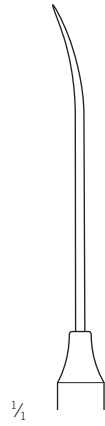

43-400-03
Fig. 3

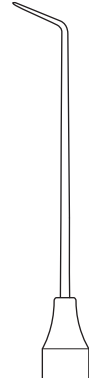

43-400-06
Fig. 6



43-400-08
Fig. 8 A

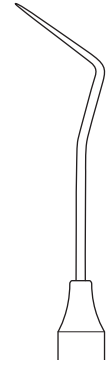

43-400-09
Fig. 9

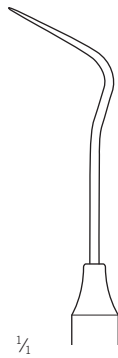

43-400-12
Fig. 12



43-400-17
Fig. 17

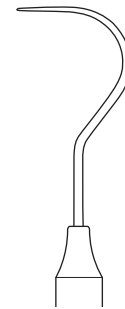

43-400-23
Fig. 23

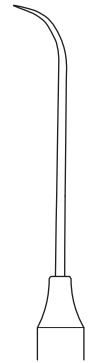

43-400-30
Fig. 3A

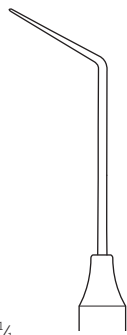

43-400-60
Fig. 6XL

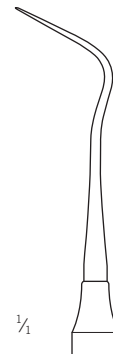

White
43-401-12
Fig. 12

43-400-03 -
43-401-12
17,5 cm / 6 7/8"
extra feine Zahnsonde
extra delicate tooth probe
sonda dental extradelicada
sonde dentaire extra fine
sonda dentale superfine
massiver Griff, 6 mm
solid handle, 6 mm
mango sólido, 6 mm
poignée massive, 6 mm
manico cavo, 6 mm

Zahnsonden

Explorers
Sondas
Sondes
Sonde

Reinigungsinstrumente

Scalers, periodontology
Limpiadores de sarro, parodontología
Instruments à détartrer, parodontologie
Ablatori di tartaro, parodontologia

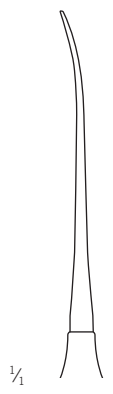
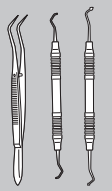

43-402-03

Fig. 3
Lokalisierung von Furkationen und Untersuchungen im Interdentalraum
Detection of furcations and for easy entry into interproximal spaces
Detección de furcaciones y acceso fácil a los espacios interproximales
Localisation de furcations et examens dans l'espace interdentaire
Localizzazione di furcazioni e per il facile accesso a spazi interdentali

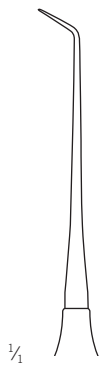

43-402-06

Fig. 6
Lokalisierung von Karies, Zahnstein, Wurzelkanälen und Furkationen
Detection of plaque, caries, root canals and furcations
Detección de sarro, caries, canales radiculares y furcaciones
Localisation de caries, de tartre, de canaux de racine et de furcations
Localizzazione di carie, tartaro, canali di radici e forcazioni



43-402-08
Fig. 8A



43-402-09
Fig. 9



Briault
43-402-11
Fig. EXD 11

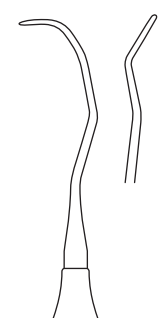

43-402-12
Fig. EXD 11-12

43-402-03 -
43-402-12
17,5 cm / 6 7/8"
massiver Griff, 6 mm
solid handle, 6 mm
mango sólido, 6 mm
poignée massive, 6 mm
manico cavo, 6 mm

Zahnsonden

Explorers
Sondas
Sondes
Sonde



43-402-17 -
43-402-66

17,5 cm / 6 7/8"

massiver Griff, 6 mm
solid handle, 6 mm
mango sólido, 6 mm
poignée massive, 6 mm
manico cavo, 6 mm



White
43-402-17

Fig. 17

Für subgingivale Untersuchung und
Approximalkaries

Mainly for sub-gingival examination and
approx. caries

Sobre todo para el examen subgingival y
caries aproximal

Pour l'examen subgingival et des
caries proximales

Principalmente per gli esami subgingivali
e carie contigue



White
43-402-23

Fig. 23

Allgemeinuntersuchung, besonders für
Schneidezähne

For general examination, especially for
incisors

Para el examen general, especialmente
de incisivos

Examen général, surtout des
incisives

Esame generale, in particolare per
gli incisivi

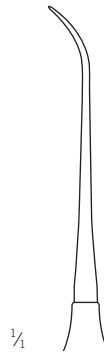

43-402-33

Fig. 3A



43-402-54

Fig. 54

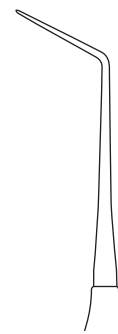

43-402-66

Fig. 6XL

Lokalisierung von Karies, Zahnstein,
Wurzelkanälen und Furkationen

Detection of plaque, caries, root canals
and furcations

Detección de sarro, caries, canales
radiculares y furcaciones

Localisation de caries, de tartre, de
canaux de racine et de furcations

Localizzazione di carie, tartaro, canali
di radici e forcazioni

Zahnsonden

Explorers
Sondas
Sondes
Sonde

Reinigungsinstrumente

Scalers, periodontology
Limpiadores de sarro, parodontología
Instruments à détartrer, parodontologie
Ablatori di tartaro, parodontologia

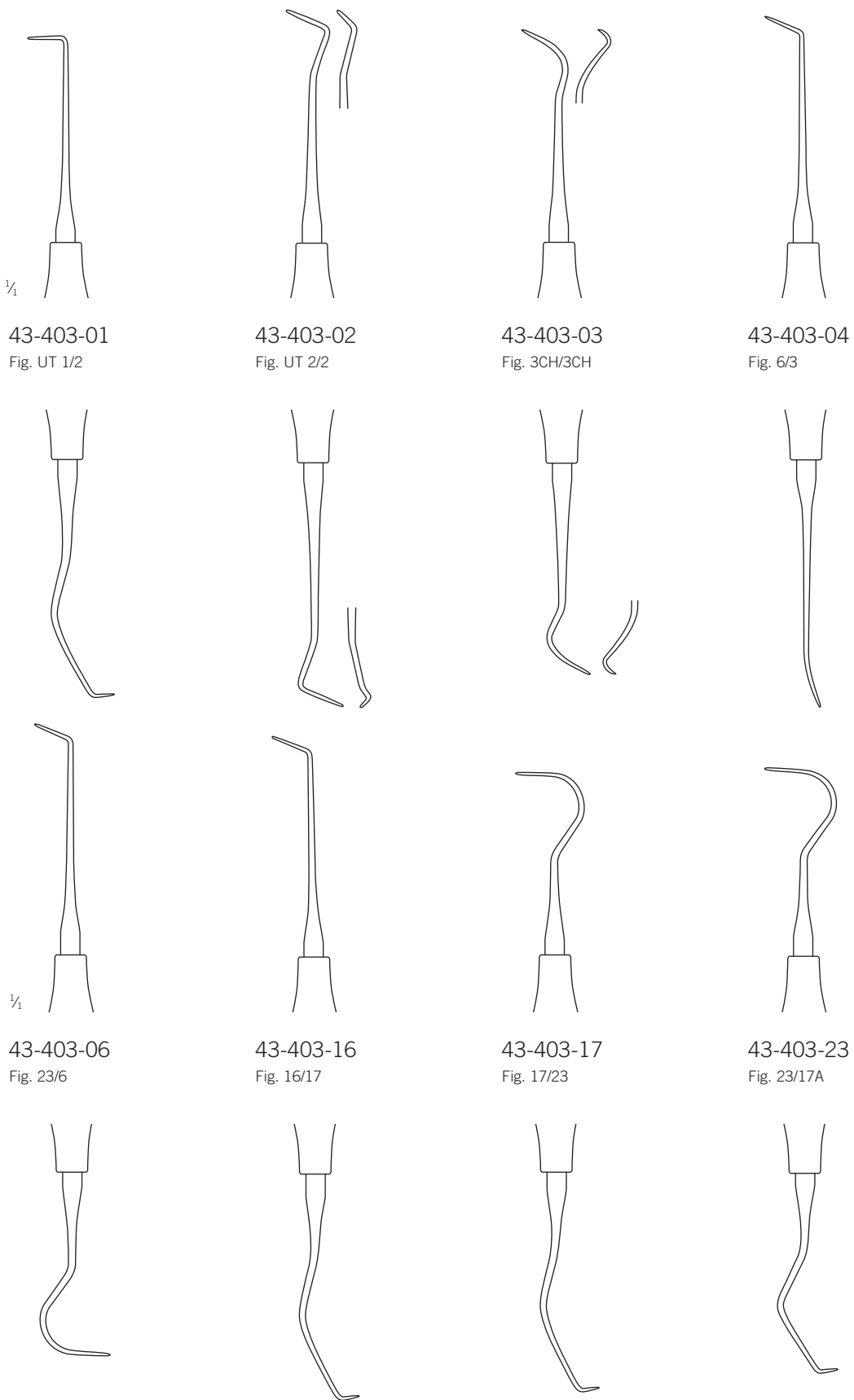
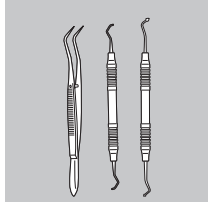

1/4

43-403-01
Fig. UT 1/2

43-403-02
Fig. UT 2/2

43-403-03
Fig. 3CH/3CH

43-403-04
Fig. 6/3

1/4

43-403-01 -
43-403-23
17,5 cm / 6 7/8"
Hohlgriff, 8 mm,
hollow handle, 8 mm
mango hueco, 8 mm
poignée creuse, 8 mm
manico cavo, 8 mm

1/4

43-403-06
Fig. 23/6

43-403-16
Fig. 16/17

43-403-17
Fig. 17/23

43-403-23
Fig. 23/17A

Zahnsonden, Zahnsonden-Ansätze

Explorers, explorers interchangeable

Sondas, sondas intercambiables

Sondes, sondes interchangeables

Sonde, sonda intercambiabili

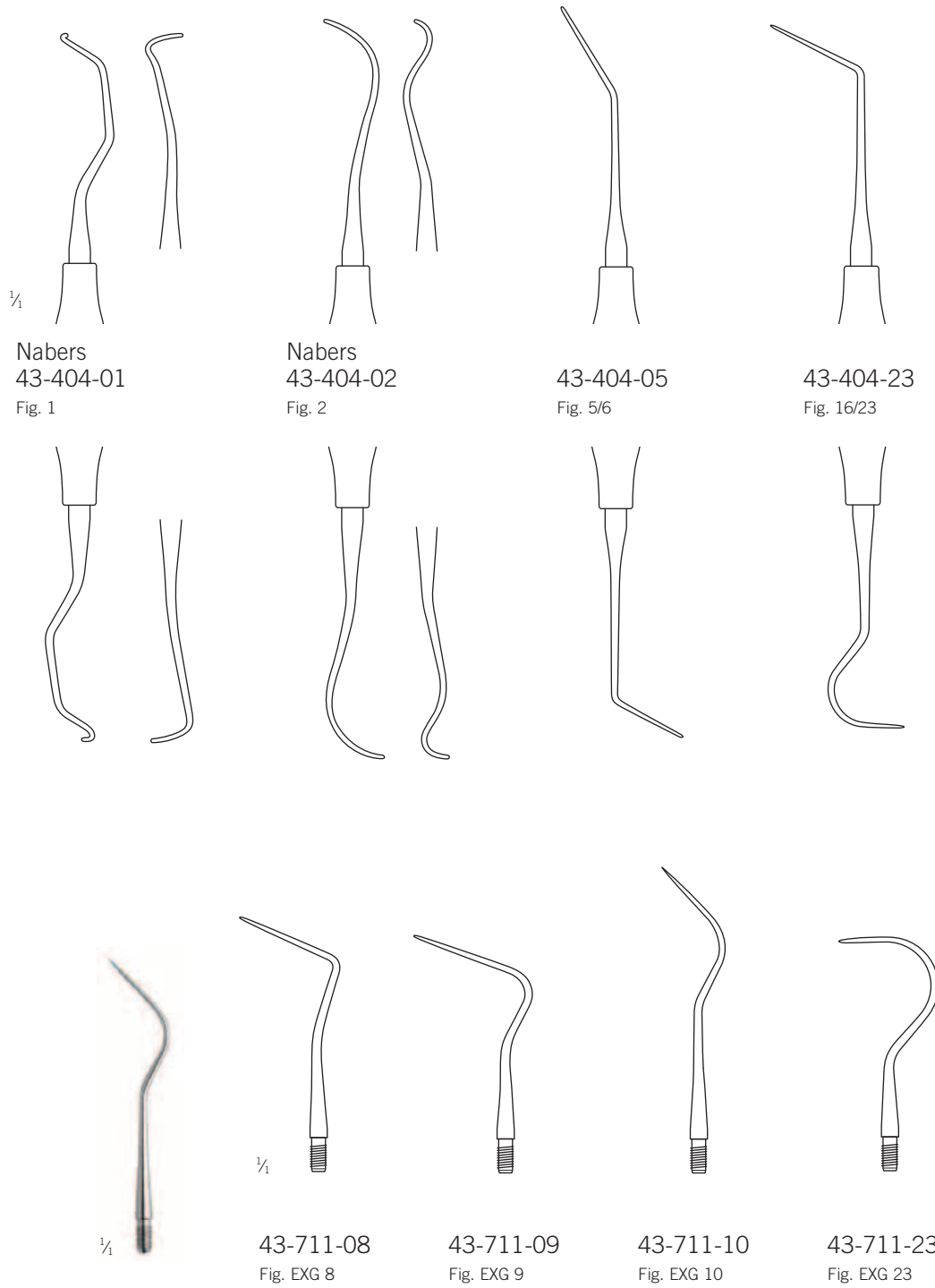

$\frac{1}{2}$
Nabers
43-404-01
Fig. 1

Nabers
43-404-02
Fig. 2

43-404-05
Fig. 5/6

43-404-23
Fig. 16/23

$\frac{1}{2}$
43-404-01 -
43-404-23
17,5 cm / 6 $\frac{7}{8}$ "
Hohlgriff, 8 mm,
hollow handle, 8 mm
mango hueco, 8 mm
poignée creuse, 8 mm
manico cavo, 8 mm

$\frac{1}{2}$

43-711-08
Fig. EXG 8

43-711-09
Fig. EXG 9

43-711-10
Fig. EXG 10

43-711-23
Fig. EXG 23

Exkavatoren

Excavators
Excavadores
Excavateurs
Escavatori

Reinigungsinstrumente

Scalers, periodontology
Limpiadores de sarro, parodontología
Instruments à détartrer, parodontologie
Ablatori di tartaro, parodontologia

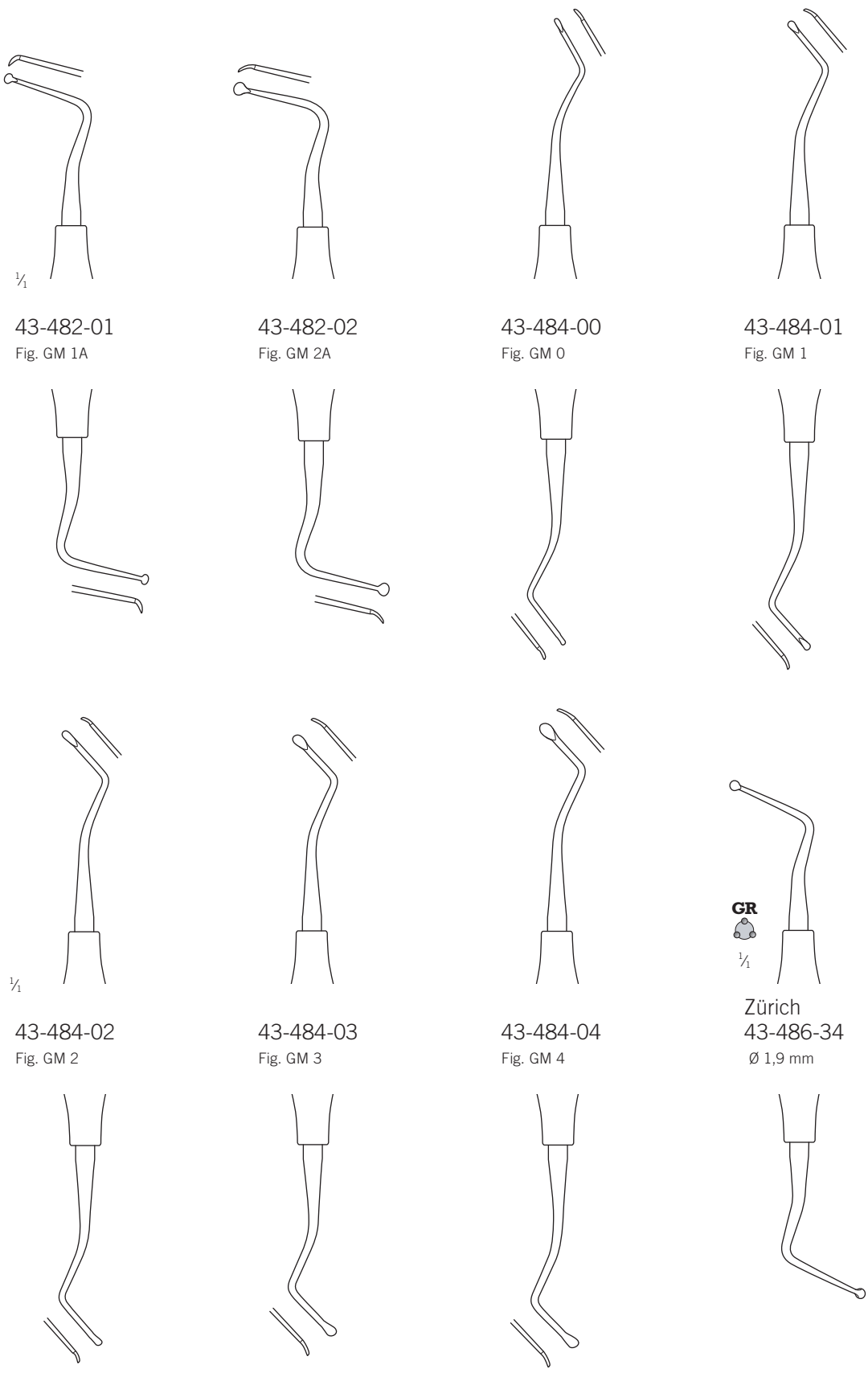
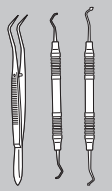

43-482-01
Fig. GM 1A

43-482-02
Fig. GM 2A

43-484-00
Fig. GM 0

43-484-01
Fig. GM 1

43-484-02
Fig. GM 2

43-484-03
Fig. GM 3

43-484-04
Fig. GM 4

GR
1/4
Zürich
43-486-34
Ø 1,9 mm

43-482-01 -
43-486-34
17,5 cm / 6 7/8"
Hohlgriff, 8 mm,
hollow handle, 8 mm
mango hueco, 8 mm
poignée creuse, 8 mm
manico cavo, 8 mm
doppelendig
double ended
de doble punta
à extrémité double
a punta doppia

- GR** = grau grey gris grigio
- Y** = gelb yellow amarillo giallo
- R** = rot red rojo rouge rosso
- G** = grün green verde verde
- V** = violett violet violeta violeta viola
- W** = weiß white blanco bianco
- B** = blau blue azul blu
- C** = hellblau light-blue azul claro bleu clair azzurro

Exkavatoren

Excavators
Excavadores
Excavateurs
Escavatori

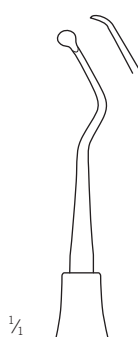

43-487-00
Fig. GM 125/126

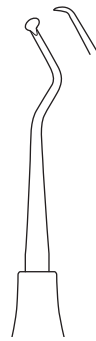

43-487-02
Fig. GM 127/128

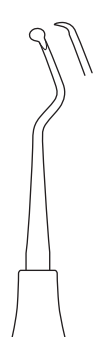

43-487-04
Fig. GM 129/130



43-487-06
Fig. GM 133/134

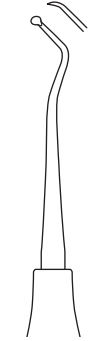

43-487-08
Fig. GM 153/154



43-487-10
Fig. GM 14

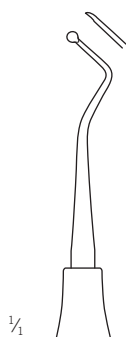

43-487-12
Fig. GM 38/39



43-487-14
Fig. GM E1



43-487-16
Fig. GM E2



43-487-18
Fig. GM E3

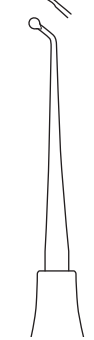

43-487-20
Fig. GM 6



43-487-22
Fig. GM 17S

43-487-00 -
43-487-22

17,5 cm / 6 7/8"

Hohlgriff, 8 mm
hollow handle, 8 mm
mango hueco, 8 mm
poignée creuse, 8 mm
manico cavo, 8 mm

doppelendig
double ended
de doble punta
à extrémité double
a punta doppia



Exkavatoren

Excavators
Excavadores
Excavateurs
Escavatori

Reinigungsinstrumente

Scalers, periodontology
Limpiadores de sarro, parodontología
Instruments à détartrer, parodontologie
Ablatori di tartaro, parodontologia

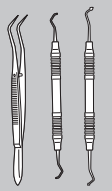

43

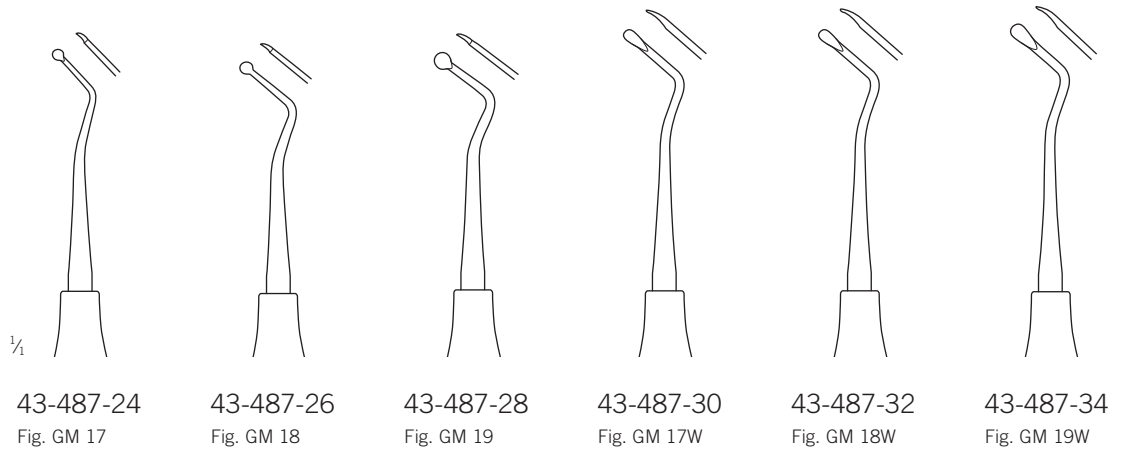

43-487-24 Fig. GM 17 43-487-26 Fig. GM 18 43-487-28 Fig. GM 19 43-487-30 Fig. GM 17W 43-487-32 Fig. GM 18W 43-487-34 Fig. GM 19W

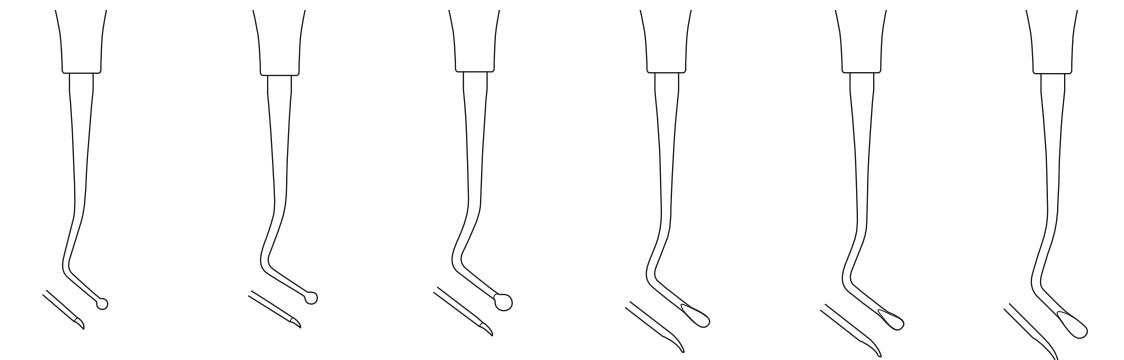

43-487-35 Fig. GM 61/62 43-487-36 Fig. GM 63/64 43-487-38 Fig. GM 65/66 43-487-40 Fig. GM 31L 43-487-42 Fig. GM 32L 43-487-44 Fig. GM 33L

43-487-24 -
43-487-44
17,5 cm / 6 7/8"
Hohlgriff, 8 mm
hollow handle, 8 mm
mango hueco, 8 mm
poignée creuse, 8 mm
manico cavo, 8 mm
doppelendig
double ended
de doble punta
à extrémité double
a punta doppia

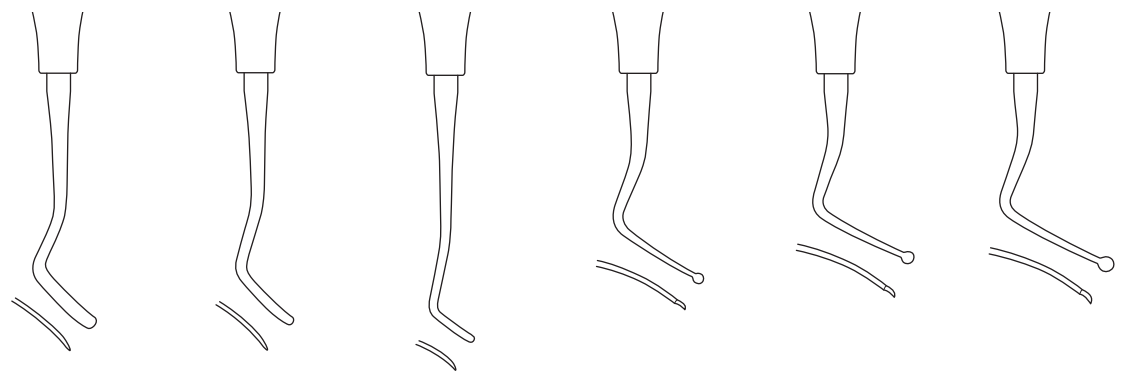

Schmelzmeißel

Enamel chisels

Cinceles para esmalte

Ciseaux à émail

Tagliasmalto



Black
43-493-01
Fig. 1



Black
43-493-02
Fig. 2



Black
43-493-26
Fig. 26



Black
43-493-27
Fig. 27



Black
43-493-28
Fig. 28



Black
43-493-29
Fig. 29



Black
43-493-52
Fig. 51/52



Black
43-493-54
Fig. 53/54



Black
43-493-64
Fig. 63/64



Black
43-493-66
Fig. 65/66



Black
43-493-78
Fig. 77/78



Black
43-493-80
Fig. 79/80



43-493-01 -
43-493-80

17,5 cm / 6 7/8"

massiver Griff, 6 mm

solid handle, 6 mm

mango sólido, 6 mm

poignée massive, 6 mm

solida impugnatura, 6 mm

doppelendig

double ended

de doble punta

à extrémité double

a punta doppia

Schmelzmeißel

Enamel chisels
Cinceles para esmalte
Ciseaux à émail
Tagliasmalto

Reinigungsinstrumente

Scalers, periodontology
Limpiadores de sarro, parodontología
Instruments à détartrer, parodontologie
Ablatori di tartaro, parodontologia

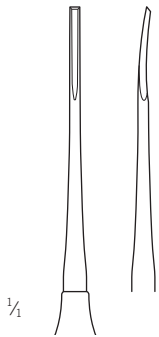
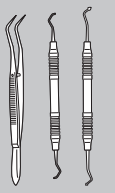

1/1
Wedelstaedt
43-494-02
Fig. 1/2

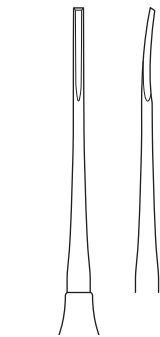

Wedelstaedt
43-494-04
Fig. 3/4

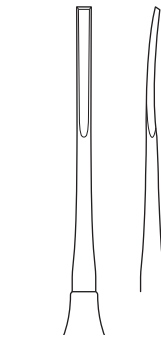

Wedelstaedt
43-494-06
Fig. 5/6

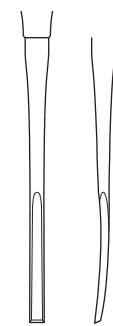
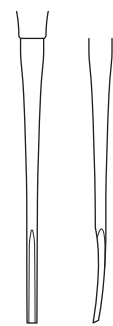
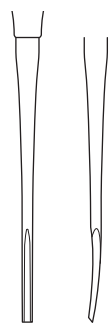

43-494-02 -
43-494-06
17,5 cm / 6 7/8"
massiver Griff, 6 mm
solid handle, 6 mm
mango sólido, 6 mm
poignée massive, 6 mm
solida impugnatura, 6 mm
doppelendig
double ended
de doble punta
à extrémité double
a punta doppia

Nervkanal-Instrumente

Root canal instruments
Instrumentos para canales
Instruments à canaux
Strumenti per trattamenti canalari

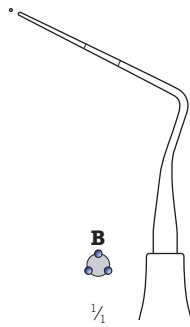

1/4

Zürich
43-500-31

Fig. 30/40

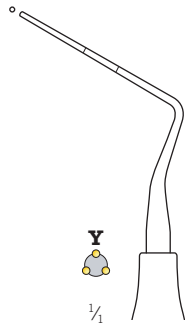

1/4

Zürich
43-500-51

Fig. 50/90

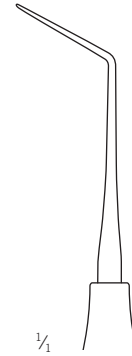

1/4

Stewart
43-504-01



1/4

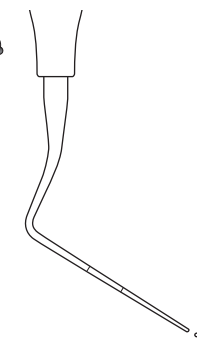

Plugger
Plugger
Obturador
Obturateur
Otturatore



1/4

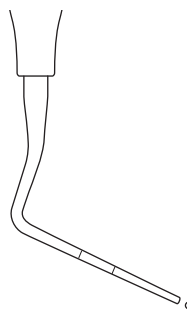

Plugger
Plugger
Obturador
Obturateur
Otturatore



Endo-Sonde
Endo probe
Endosonda
Endosonda
Endosonda

1/4

43-500-31 -
43-504-01

17,5 cm / 6 7/8"

Hohlgriff, 8 mm
hollow handle, 8 mm
mango hueco, 8 mm
poignée creuse, 8 mm
manico cavo, 8 mm

doppelendig
double ended
de doble punta
à extrémité double
a punta doppia



GR = grau
grey
gris
gris
grigio



Y = gelb
yellow
amarillo
jaune
giallo



R = rot
red
rojo
rouge
rosso



G = grün
green
verde
vert
verde



V = violett
violet
violeta
violet
viola



W = weiß
white
blanco
blanc
bianco



B = blau
blue
azur
bleu
blu



N = schwarz
black
negro
noir
nero

Nervkanal-Instrumente

Root canal instruments
Instrumentos para canales
Instruments à canaux
Strumenti per trattamenti canalari

Reinigungsinstrumente

Scalers, periodontology
Limpiadores de sarro, parodontología
Instruments à détartrer, parodontologie
Ablatori di tartaro, parodontologia

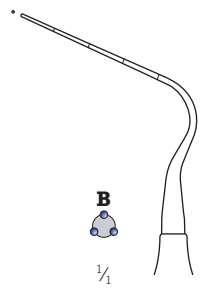
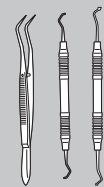

43-505-03
Fig. 30

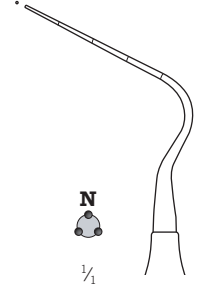

43-505-04
Fig. 40

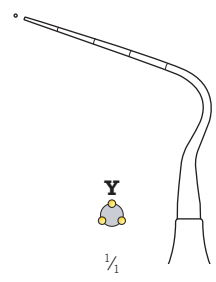

43-505-05
Fig. 50

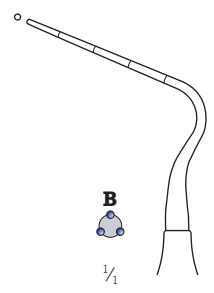

43-505-06
Fig. 60

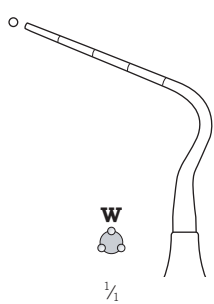

43-505-09
Fig. 90

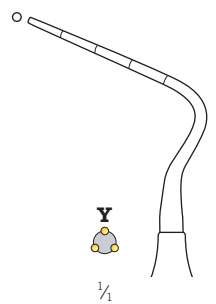

43-505-10
Fig. 100

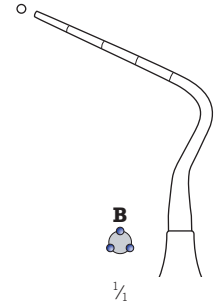

43-505-12
Fig. 120

Plugger
Plugger
Obturador
Obturateur
Otturatore

1/4

43-505-03 -
43-505-12
17,5 cm / 6 7/8"
massiver Griff, 6 mm
solid handle, 6 mm
mango sólido, 6 mm
poignée massive, 6 mm
solida impugnatura, 6 mm
einendig
single ended
de una sola punta
à une extrémité
a una sola punta

Nervkanal-Instrumente

Root canal instruments
Instrumentos para canales
Instruments à canaux
Strumenti per trattamenti canalari



1/1

43-506-01 -
43-507-06

16 cm / 6 1/8"

massiver Griff, 6 mm
solid handle, 6 mm
mango sólido, 6 mm
poignée massive, 6 mm
solida impugnatura, 6 mm

einendig
single ended
de una sola punta
à une extrémité
a una sola punta

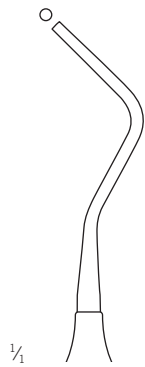

43-506-01

Fig. 1



43-506-02

Fig. 2



43-506-03

Fig. 3

Plugger
Plugger
Obturador
Obturateur
Otturatore

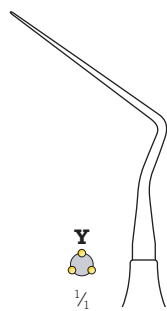

43-507-02

Fig. 20



43-507-03

Fig. 30



43-507-04

Fig. 40

Spreader
Spreader
Extendedor
Etendeur
Estensore



43-507-05

Fig. 50

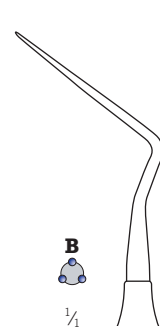

43-507-06

Fig. 60

Spreader
Spreader
Extendedor
Etendeur
Estensore

GR = grau
grey
gris
gris
grigio

Y = gelb
yellow
amarillo
jaune
giallo

R = rot
red
rojo
rouge
rosso

G = grün
green
verde
vert
verde

V = violett
violet
violeta
violet
viola

W = weiß
white
blanco
blanc
bianco

B = blau
blue
azur
blanc
blu

N = schwarz
black
negro
noir
nero

Gingivektomiemesser

Gingivectomy knives
Bisturías para la gingivectomía
Bistouris pour la gingivectomie
Bisturie per gengivectomia

Reinigungsinstrumente

Scalers, periodontology
Limpiadores de sarro, parodontología
Instruments à détartrer, parodontologie
Ablatori di tartaro, parodontologia

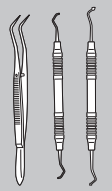

43



1/4

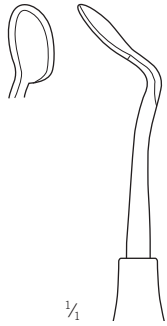

43-326-37
Fig. 7



43-326-38
Fig. 8



43-326-39
Fig. 9



43-326-40
Fig. 10



43-326-41
Fig. 11

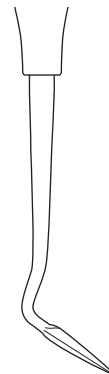
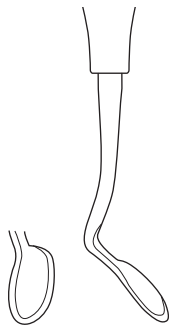

43-326-37 -
43-326-41

17,5 cm / 6 7/8"

massiver Griff, 6 mm
solid handle, 6 mm
mango sólido, 6 mm
poignée massive, 6 mm
solida impugnatura, 6 mm

doppelendig
double ended
de doble punta
à extrémité double
a punta doppia

Gingivektomiemesser

Gingivectomy knives

Bisturías para la gingivectomía

Bistouris pour la gingivectomie

Bisturie per gengivectomia

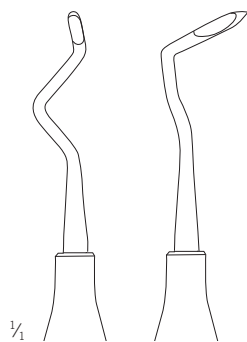

38-050-03

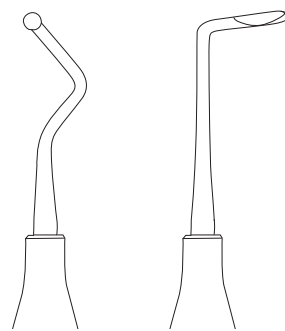

38-050-04

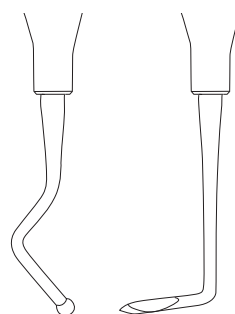
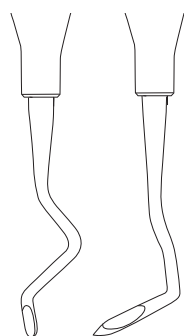

1/4

Allen-Iglhaut
38-050-03 -
38-050-04



16 cm / 6 1/8"

Hohlgriff, 10 mm
hollow handle, 10 mm
mango hueco, 10 mm
poignée creuse, 10 mm
manico cavo, 10 mm

doppelendig
double ended
de doble punta
à extrémité double
a punta doppia

Gingivektomiemesser

Gingivectomy knives
 Bisturíes para la gingivectomía
 Bistouris pour la gingivectomie
 Bisturie per gengivectomia

Parodontologie

Periodontology
 Parodontología
 Parodontologie
 Parodontologia

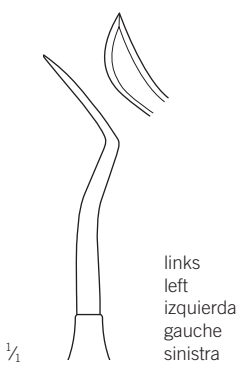
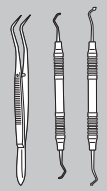

Kirkland
 43-331-51

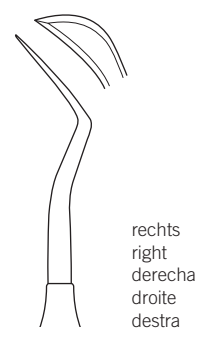

Kirkland
 43-331-61

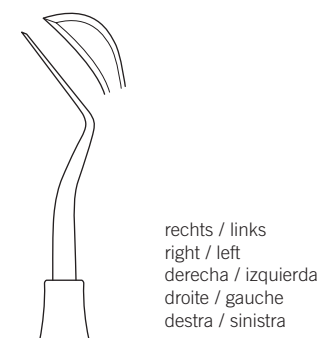

Kirkland
 43-332-61

Für Gingivektomie und Rekonturierung der Gingiva.
 Sehr wirksam im retromolaren Bereich

For gingivectomy or gingivoplastic surgery.
 Very effective in retro molar region

Para la gingivectomía o cirugía gingivoplástica.
 Muy eficaz en la región retromolar

Pour gingivectomie et gengivoplastie chirurgicale.
 Très efficace dans la région rétromolaire

Per la gengivectomia e la chirurgia gengivoplastica.
 Molto efficace nella regione retromolare

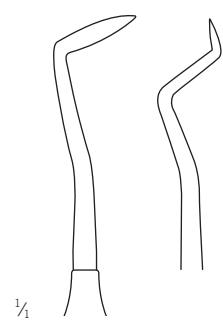

Orban
 43-333-01

Fig. 1

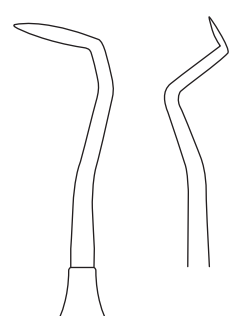

Orban
 43-333-02

Fig. 2

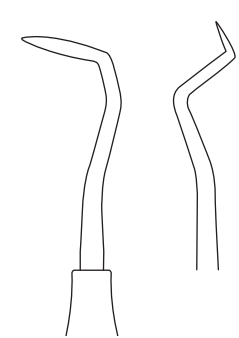

Orban
 43-333-12

Fig. 1/2

43-331-51 -
 43-333-12

16 cm / 6 1/8"
 massiver Griff, 6 mm
 solid handle, 6 mm
 mango sólido, 6 mm
 poignée massive, 6 mm
 solida impugnatura, 6 mm

einendig
 single ended
 de una sola punta
 à une extrémité
 a una sola punta

Mit kontragewinkeltem Schaft, speziell für posteriore Anwendung
 sowie für das Exzidieren von interproximalem Gewebe bei Gingivektomie

Counter angled shank, especially suitable for excision of
 interproximal tissue in gingivectomy

Vástago contraangular, especialmente idóneo para la extracción del
 tejido interproximal en gingivectomía

Avec tige contre coudée, spéciale pour application postérieure
 et excision de tissus interproximaux en gingivectomie

Con stelo controangolato, speciale per l'asportazione di tessuto
 interprossimale in gengivectomia

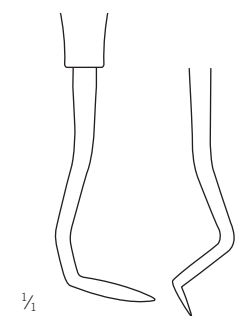

44

Füllungsinstrumente

Filling instruments
Instrumentos para obturaciones
Instruments pour plombages
Otturatori

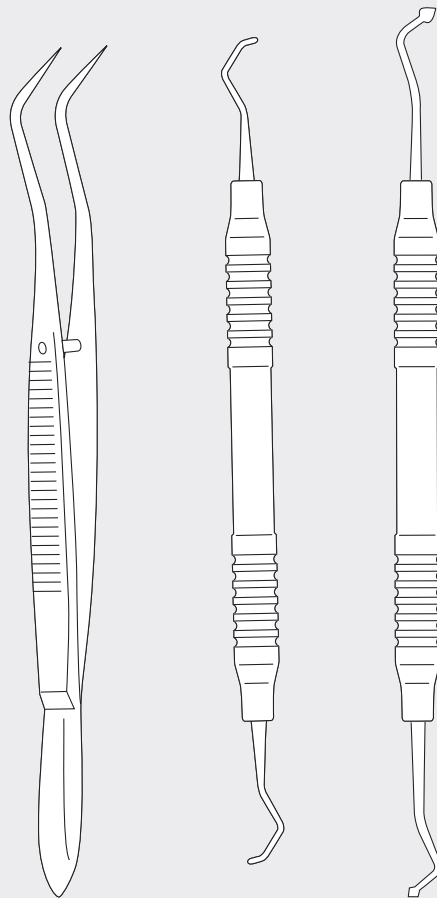

Amalgaminstrumente

Amalgam instruments
Instrumentos amalgamas
Instruments à amalgame
Strumenti per amalgama

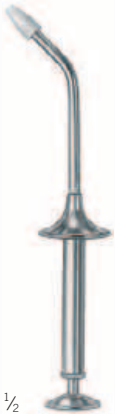

½

44-187-01

Amalgampistole
Amalgam carrier
Porta amalgamas
Pistolet pour amalgame
Cucchiaino portamalgama

gewinkelt
angled
acodado
coudé
angolato



½

44-185-01

Amalgampistole
Amalgam carrier
Porta amalgamas
Pistolet pour amalgame
Cucchiaino portamalgama

leicht gebogen
slightly curved
ligeramente curvo
légèrement courbé
leggermente curvo



¼

44-187-05

Kunststoffansatz allein zu 44-185-01 und 44-187-01
Plastic tip alone for 44-185-01 and 44-187-01
Sólo aditamento de plástico para 44-185-01 y 44-187-01
Appendice en plastique uniquement pour 44-185-01 et 44-187-01
Accessorio in plastica per 44-185-01 e 44-187-01



¼

44-200-30

Amalgam-Fingerbecher, Boden flach
Amalgam finger bowl, bottom flat
Vaso para dedos de amalgama, base plana
Coupelle pour amalgame, fond plat
Vaso di amalgama, base piana



¼

44-200-31

Amalgam-Fingerbecher, Boden rund
Amalgam finger bowl, bottom round
Vaso para dedos de amalgama, base redonda
Coupelle pour amalgame, fond rond
Vaso di amalgama, base tonda

Füllungsinstrumente

Filling instruments

Instrumentos para obturaciones

Instrumentos pour plombages

Otturatori

Füllungsinstrumente

Filling instruments

Instrumentos para obturaciones

Instrumentos pour plombages

Otturatori

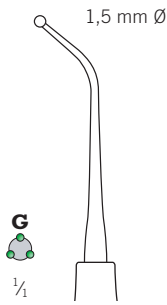
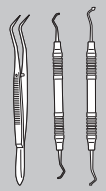

44-269-03

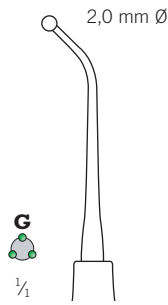

44-269-04

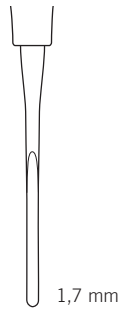

1,7 mm

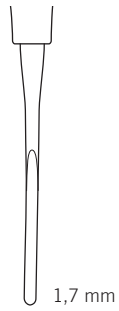

1,7 mm

1/4

Zürich

44-269-03 - 44-269-04

17 cm / 6 5/8"

Kugelstopfer/Spatel-Kombination

Ball type condenser/spatula combination

Combinación condensador tipo bola/espátula

Combinaison obturateur à bille/spatule

Combinazione spatola/otturatore a sfera

Hohlgriff, 8 mm

hollow handle, 8 mm

mango hueco, 8 mm

poignée creuse, 8 mm

manico cavo, 8 mm

Ideal für Füllungen von retrograd mit MTA oder Super EBA

Ideal for retrograde fillings with MTA and Super EBA

Ideal para empastes retrógrados con MTA y Super EBA

Idéal pour le remplissage rétrograde avec du matériel MTA et Super EBA

Ideale per otturazioni retrograde con MTA e Super EBA

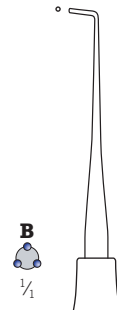

44-272-03
17,5 cm / 6 3/4"

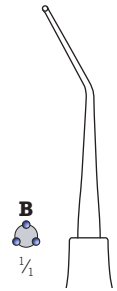

44-272-04
P / 6 3/4"

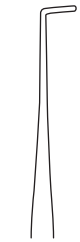

90° einfach gewinkelt
90° angle, single
ángulo 90°, sencillo
angle de 90°, simple
angolo di 90°, semplice

90° gewinkelt mit Kontrawinkel
90° angle with counter angle
ángulo 90° con contraángulo
angle de 90° avec contre angle
angolo di 90°, con controangolo

1/4

Zürich

44-272-03 - 44-272-04

16,5 cm / 6 1/2"

Planstopfer "Retrograd"

Plane condenser "Retrograd"

Condensador plano "Retrograd"

Obturateur plan "Retrograd"

Otturatore piano "Retrograd"

Hohlgriff, 8 mm

hollow handle, 8 mm

mango hueco, 8 mm

poignée creuse, 8 mm

manico cavo, 8 mm

Ideal für Füllungen von retrograd mit MTA oder Super EBA

Ideal for retrograde fillings with MTA and Super EBA

Ideal para empastes retrógrados con MTA y Super EBA

Idéal pour le remplissage rétrograde avec du matériel MTA et Super EBA

Ideale per otturazioni retrograde con MTA e Super EBA

Kompositinstrument

Composite instrument
 Instrumento compuesto
 Instrument composite
 Strumento composto

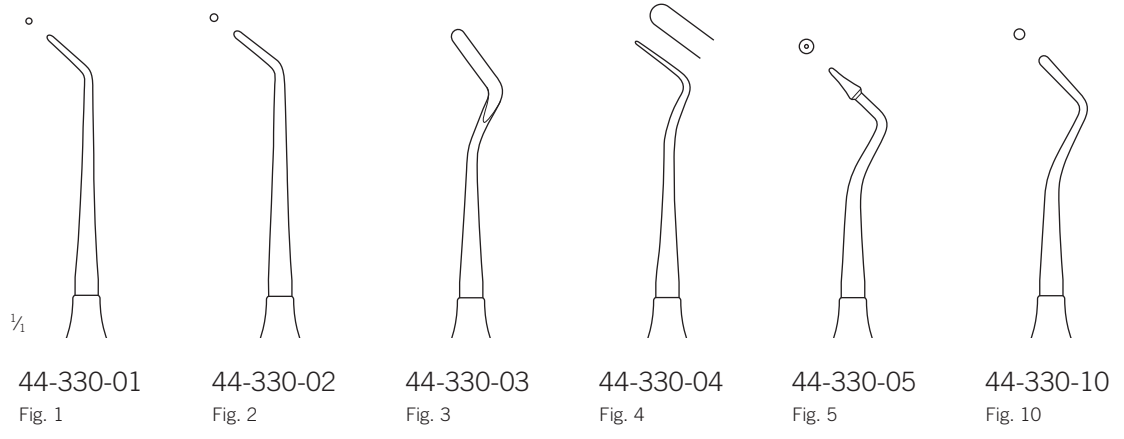

44-330-01 Fig. 1 44-330-02 Fig. 2 44-330-03 Fig. 3 44-330-04 Fig. 4 44-330-05 Fig. 5 44-330-10 Fig. 10

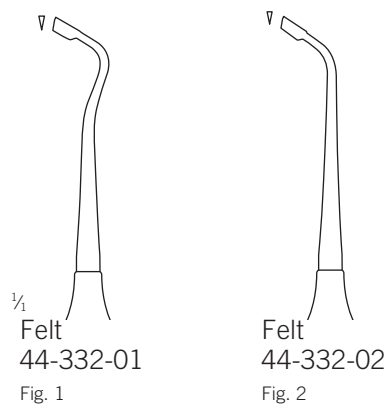
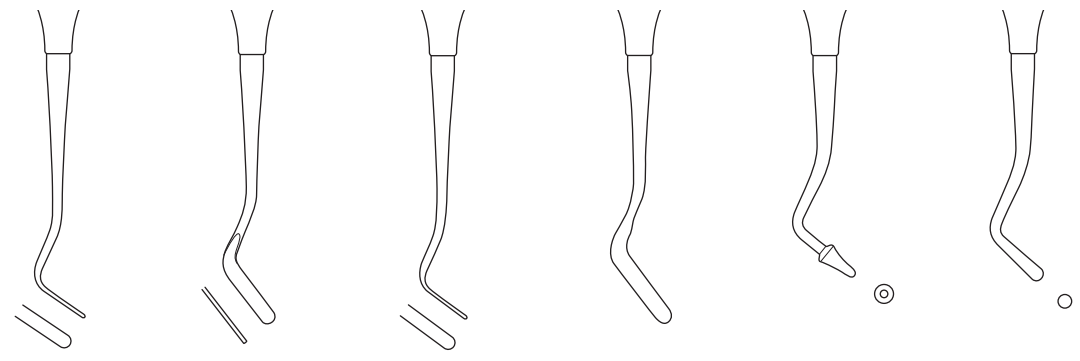

1/4 Felt 44-332-01 Fig. 1 1/4 Felt 44-332-02 Fig. 2

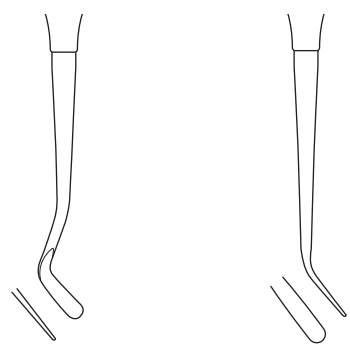

44-330-01 -
 44-332-02

17,5 cm / 6 7/8"

titanbeschichtet, massiver Griff, 6 mm
 titanium coated, solid handle, 6 mm
 con revestimiento de titanio, mango sólido, 6 mm
 revêtu de titane, poignée massive, 6 mm
 con rivestimento in titano, solida impugnatura, 6 mm

titanbeschichtet
 nichthaftend
 titanium coated
 non adhesive
 con revestimiento
 de titanio
 no adhesivo
 recouvert de titane
 non adhésif
 con rivestimento
 in titano
 non adesivo

Kompositinstrument

Composite instrument
Instrumento compuesto
Instrument composite
Strumento composito

Füllungsinstrumente

Filling instruments
Instrumentos para obturaciones
Instruments pour plombages
Otturatori

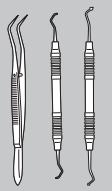

1/4

44-332-03 -
44-334-04

17,5 cm / 6 7/8"

titanbeschichtet, massiver Griff, 6 mm
titanium coated, solid handle, 6 mm
con revestimiento de titanio, mango sólido, 6 mm
revêtu de titane, poignée massive, 6 mm
con rivestimento in titanio, solida impugnatura

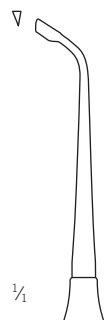

1/4

Felt
44-332-03
Fig. 3



Felt
44-332-04
Fig. 4

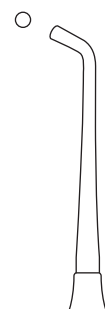

Felt
44-332-05
Fig. 5

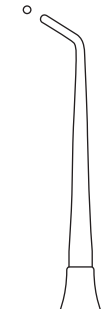

Felt
44-332-06
Fig. 6

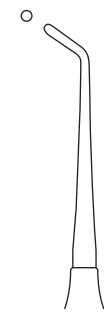
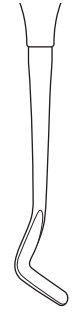

Goldstein
44-334-01
Fig. 1

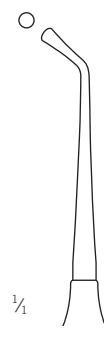

1/4

Goldstein
44-334-02
Fig. 2



Goldstein
44-334-03
Fig. 3



Goldstein
44-334-04
Fig. 4



titanbeschichtet
nichthaftend
titanium coated
non adhesive
con revestimiento
de titanio
no adhesivo
recouvert de titane
non adhésif
con rivestimento
in titanio
non adesivo

Kompositinstrument

Composite instrument
Instrumento compuesto
Instrument composite
Strumento composto

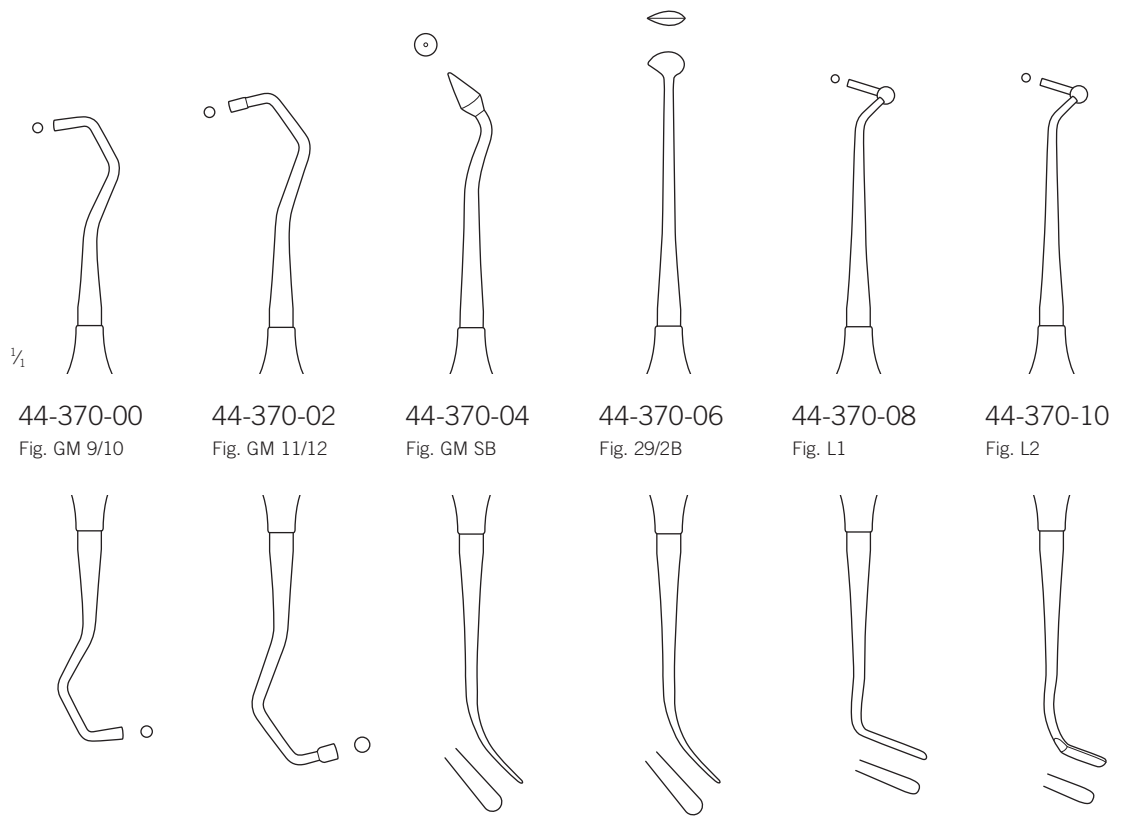

44-370-00
Fig. GM 9/10

44-370-02
Fig. GM 11/12

44-370-04
Fig. GM SB

44-370-06
Fig. 29/2B

44-370-08
Fig. L1

44-370-10
Fig. L2

44-370-00 -
44-370-10

17,5 cm / 6 7/8"

massiver Griff, 6 mm

solid handle, 6 mm

mango sólido, 6 mm

poignée massive, 6 mm

solida impugnatura, 6 mm

Elefantenfußstopfer

Elephant foot condenser
Condensador pie de elefante
Obturateur pied d'éléphant
Otturatore a piede di elefante

Füllungsinstrumente

Filling instruments
Instrumentos para obturaciones
Instruments pour plombages
Otturatori

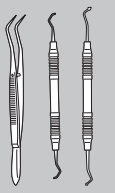

1/4

44-375-00

Fig. 0



44-375-01

Fig. 1



44-375-02

Fig. 2



1/4

44-375-00 -
44-375-02

17,5 cm / 6 7/8"

massiver Griff, 6 mm
solid handle, 6 mm
mango sólido, 6 mm
poignée massive, 6 mm
solida impugnatura, 6 mm

Kugelstopfer, Polierinstrumente

Ball type condenser, polisher

Condensador tipo bola, instrumentos para pulir

Obturateur à bille, polissoir

Otturatore a sfera, lucidatore



44-377-01
Fig. 1



44-377-02
Fig. 2



44-377-03
Fig. 3



44-377-04
Fig. 4



44-377-05
Fig. 5



44-377-18
Fig. 18



44-377-27
Fig. 26/27S



44-377-28
Fig. 28/29



44-377-29
Fig. 27/29

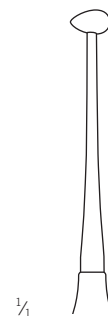

Polierinstrument
Polisher
Instrumento para pulir
Polissoir
Lucidatore

44-377-01 -
44-377-29

17,5 cm / 6 7/8" massiver Griff, 6 mm
solid handle, 6 mm
mango sólido, 6 mm
poignée massive, 6 mm
solida impugnatura, 6 mm

Planstopfer

Plane condenser
Condensador plano
Obturateur plan
Otturatore piano

Füllungsinstrumente

Filling instruments
Instrumentos para obturaciones
Instruments pour plombages
Otturatori

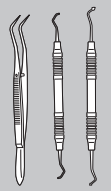

44-379-01
Fig. 1



44-379-02
Fig. 2



44-379-03
Fig. 3



1/4

44-379-01 -
44-379-03

17,5 cm / 6 7/8"

massiver Griff, 6 mm
solid handle, 6 mm
mango sólido, 6 mm
poignée massive, 6 mm
solida impugnatura, 6 mm



44-379-11
Fig. 1S



44-379-12
Fig. 2S



44-379-13
Fig. 3S



1/4

44-379-11 -
44-379-13

17,5 cm / 6 7/8"

massiver Griff, 6 mm
solid handle, 6 mm
mango sólido, 6 mm
poignée massive, 6 mm
solida impugnatura, 6 mm

Füllungsinstrumente

Filling instruments

Instrumentos para obturaciones

Instruments pour plombages

Otturatori

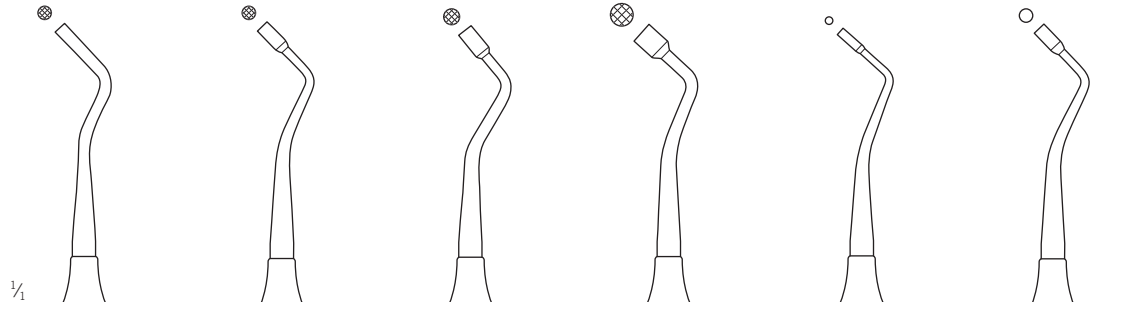

44-380-02 Fig. 1S 44-380-04 Fig. 2S 44-380-06 Fig. 3S 44-380-08 Fig. 4S 44-380-10 Fig. 1P 44-380-12 Fig. 2P

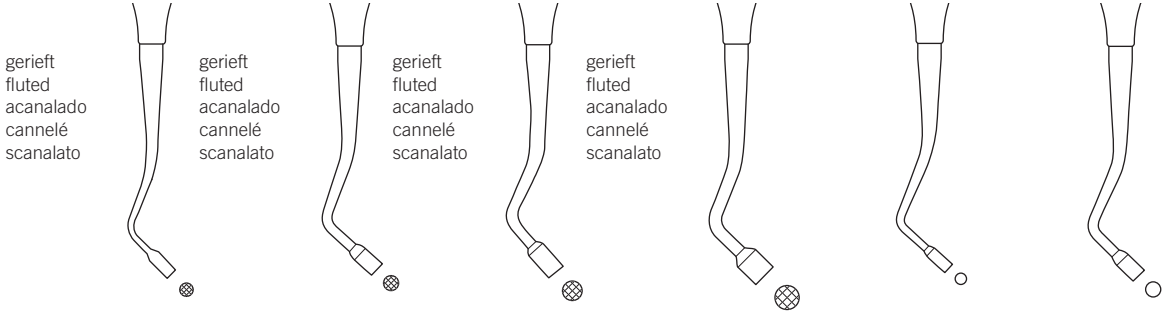

gerieft
fluted
acanalado
cannelé
scanalato

gerieft
fluted
acanalado
cannelé
scanalato

gerieft
fluted
acanalado
cannelé
scanalato

gerieft
fluted
acanalado
cannelé
scanalato

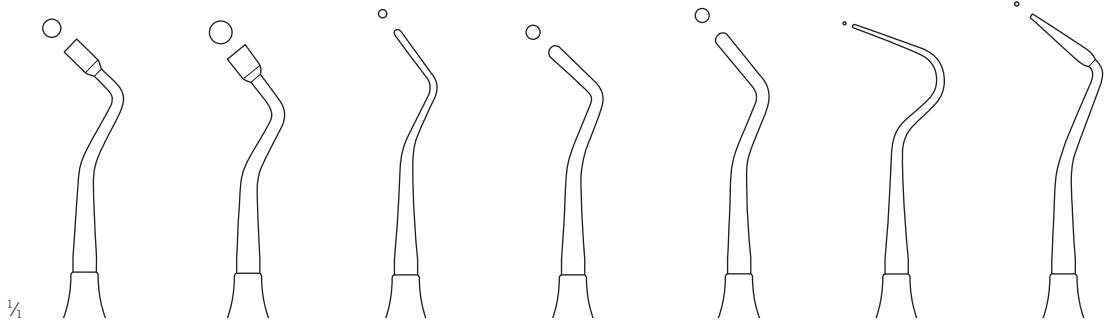

44-380-02 - 44-380-26 44-380-14 Fig. 3P 44-380-16 Fig. 4P 44-380-18 Fig. 1D 44-380-20 Fig. 2D 44-380-22 Fig. 3D 44-380-24 Fig. M1 44-380-26 Fig. M2

17,5 cm / 6 7/8"
massiver Griff, 6 mm
solid handle, 6 mm
mango sólido, 6 mm
poignée massive, 6 mm
solida impugnatura, 6 mm

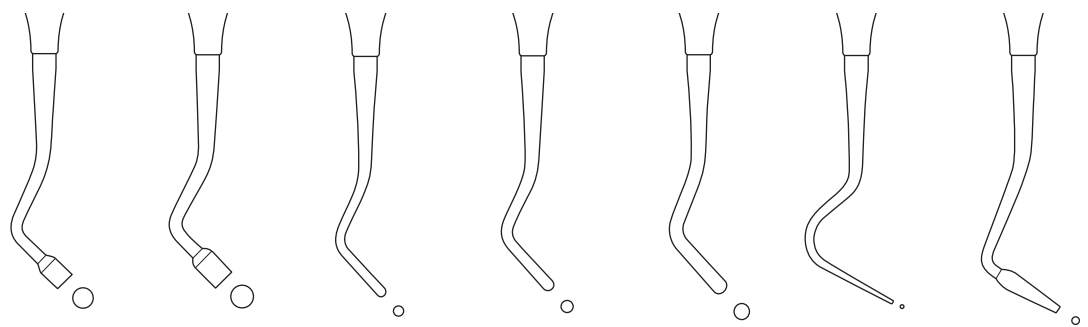

Füllungsinstrumente

Filling instruments

Instrumentos para obturaciones

Instrumentes pour plombages

Otturatori

Füllungsinstrumente

Filling instruments

Instrumentos para obturaciones

Instrumentes pour plombages

Otturatori

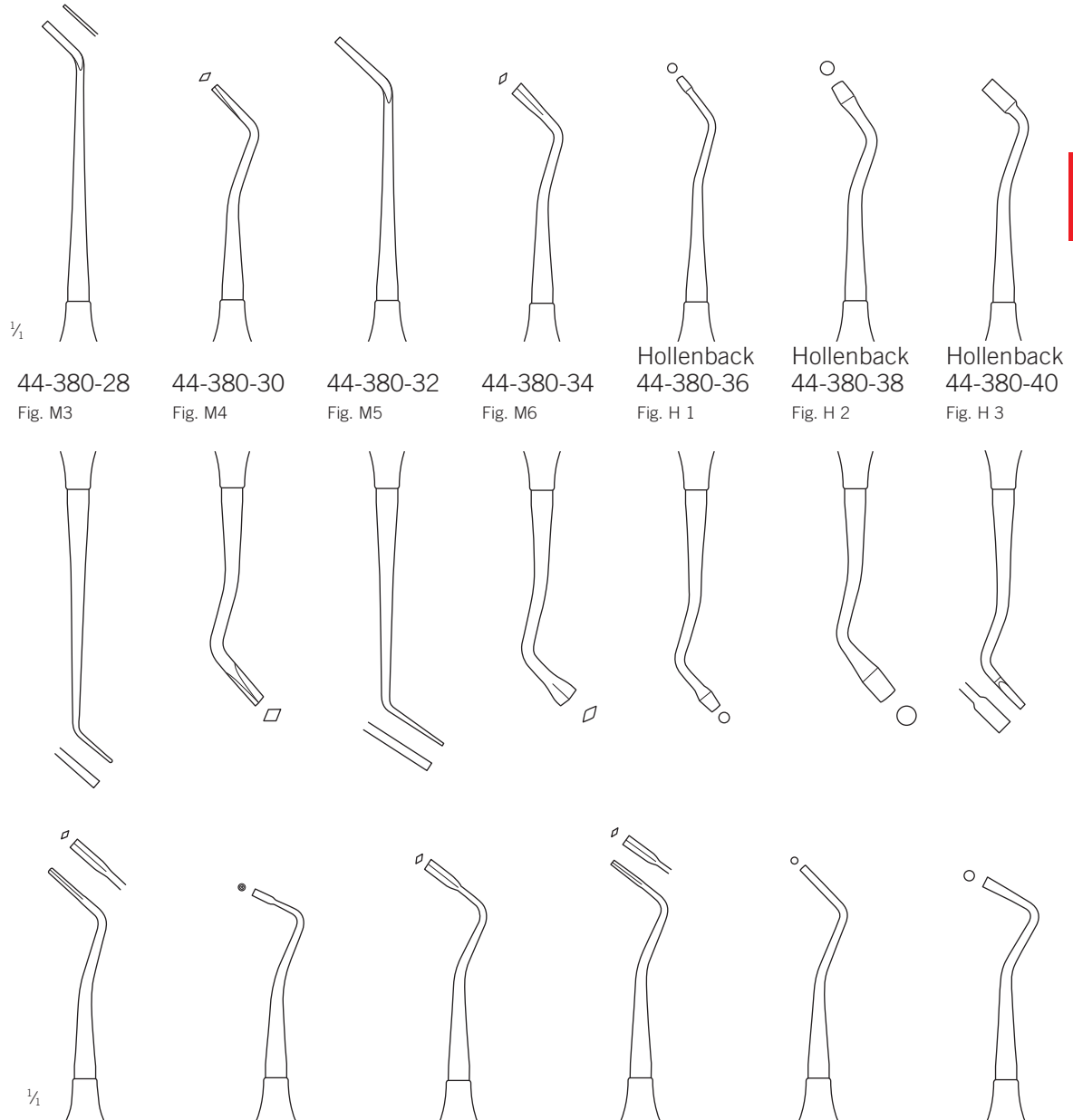
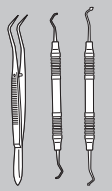

44-380-28
Fig. M3

44-380-30
Fig. M4

44-380-32
Fig. M5

44-380-34
Fig. M6

Hollenback
44-380-36
Fig. H 1

Hollenback
44-380-38
Fig. H 2

Hollenback
44-380-40
Fig. H 3

Hollenback
44-380-42
Fig. H 4

44-380-44
Fig. MQ 1S

44-380-46
Fig. T 0

44-380-48
Fig. T 1

44-380-50
Fig. T 2

44-380-52
Fig. T 3

44-380-28 -
44-380-52
17,5 cm / 6 7/8"
massiver Griff, 6 mm
solid handle, 6 mm
mango sólido, 6 mm
poignée massive, 6 mm
solida impugnatura, 6 mm

gerieft
fluted
acanalado
canalé
scanalato

Füllungsinstrumente

Filling instruments

Instrumentos para obturaciones

Instruments pour plombages

Otturatori



44-382-01

Fig. 1



44-382-02

Fig. 2



44-382-03

Fig. 3



44-382-01 -
44-382-03

17,5 cm / 6 7/8"

massiver Griff, 6 mm

solid handle, 6 mm

mango sólido, 6 mm

poignée massive, 6 mm

solida impugnatura, 6 mm

Füllungsinstrumente

Filling instruments

Instrumentos para obturaciones

Instrumentos pour plombages

Otturatori

Füllungsinstrumente

Filling instruments

Instrumentos para obturaciones

Instrumentos pour plombages

Otturatori

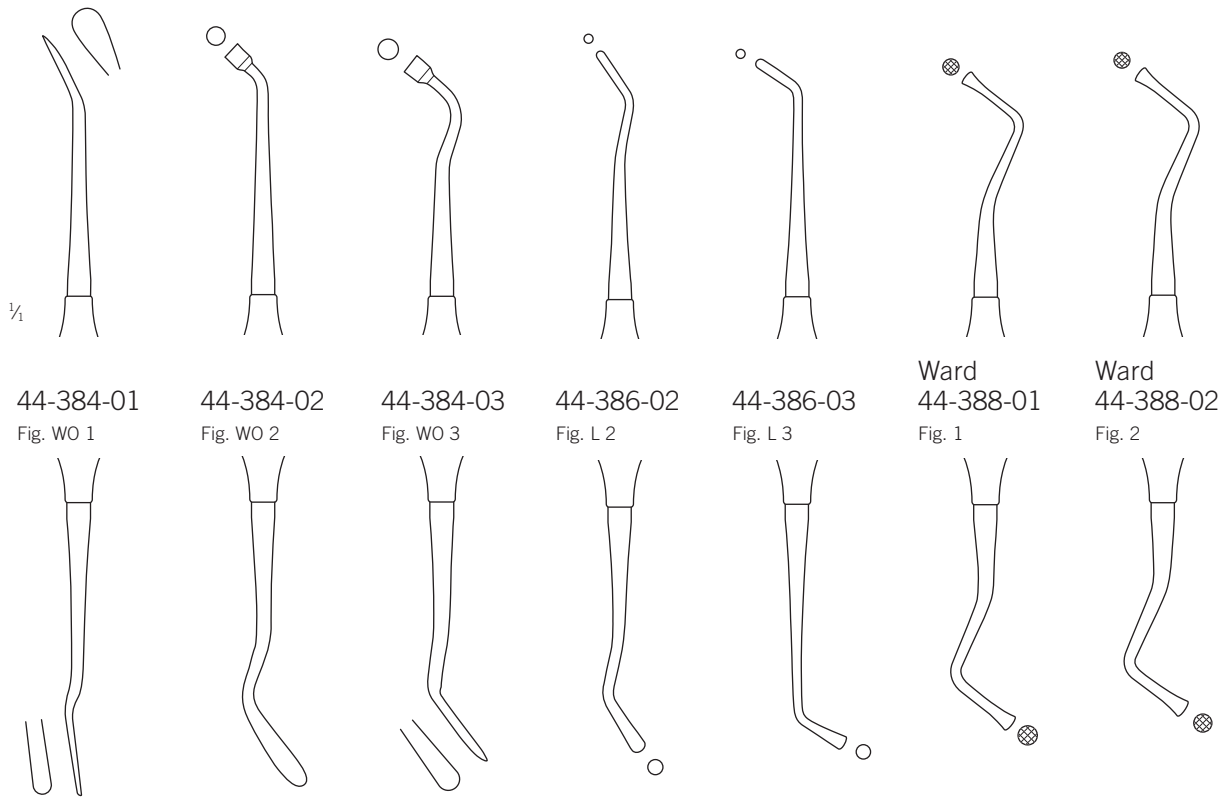
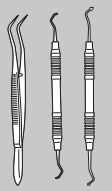

44-384-01
Fig. W0 1

44-384-02
Fig. W0 2

44-384-03
Fig. W0 3

44-386-02
Fig. L 2

44-386-03
Fig. L 3

Ward
44-388-01
Fig. 1

Ward
44-388-02
Fig. 2

44-384-01 -
44-388-02
17,5 cm / 6 7/8"
massiver Griff, 6 mm
solid handle, 6 mm
mango sólido, 6 mm
poignée massive, 6 mm
solida impugnatura, 6 mm

Kugel/Spatel-Kombination

Ball/spatula combination
 Combinación bola/espátula
 Combinaison bille/spatule
 Combinazione sfera/spatola

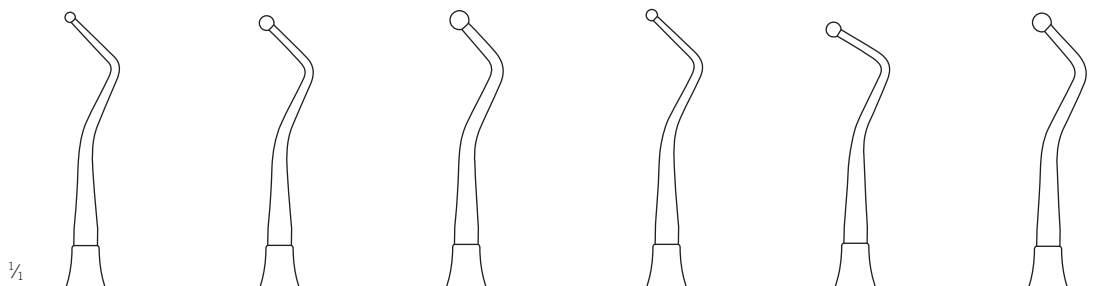

44-390-01
Fig. 1

44-390-02
Fig. 2

44-390-03
Fig. 3

44-390-11
Fig. 1A

44-390-12
Fig. 2A

44-390-13
Fig. 3A

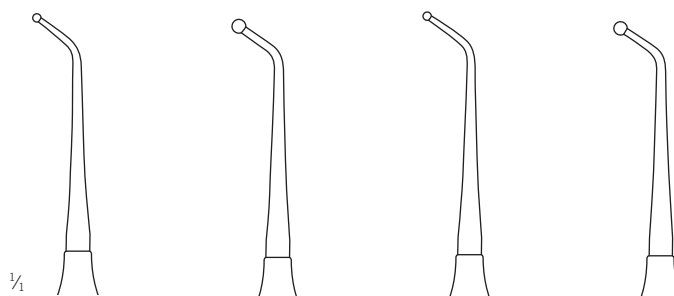
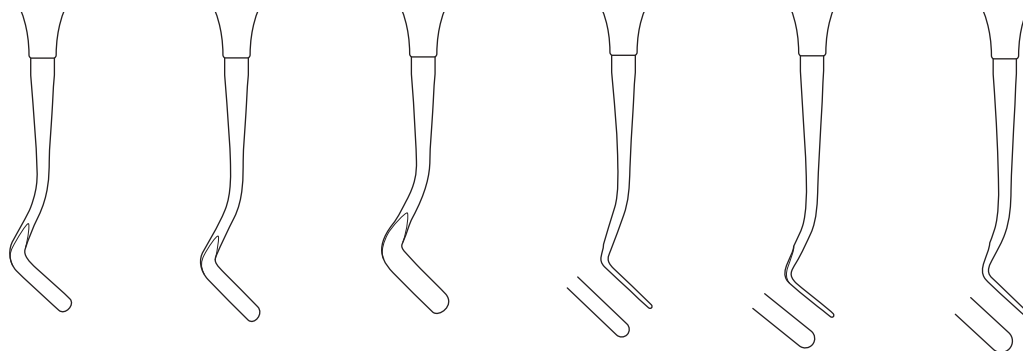

44-390-21
Fig. 1B

44-390-22
Fig. 2B

44-390-31
Fig. 1C

44-390-32
Fig. 2C

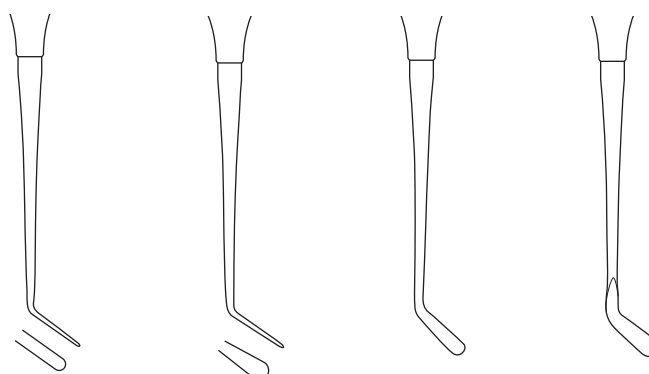

44-390-01 -
44-390-32

17,5 cm / 6 7/8"
 massiver Griff, 6 mm
 solid handle, 6 mm
 mango sólido, 6 mm
 poignée massive, 6 mm
 solida impugnatura, 6 mm

Spatel

Spatula
Espátula
Spatule
Spatola

Füllungsinstrumente

Filling instruments
Instrumentos para obturaciones
Instruments pour plombages
Otturatori

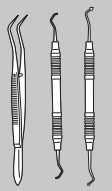

44-392-01
Fig. 1



44-392-02
Fig. 2



44-392-03
Fig. 3



44-392-10
Fig. 10

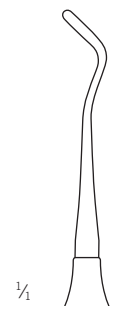
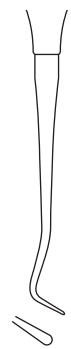

44-392-11
Fig. 11A

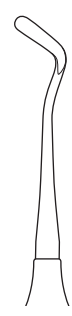

44-392-12
Fig. 12



44-392-13
Fig. 13



44-392-01 -
44-392-13

17,5 cm / 6 7/8"
massiver Griff, 6 mm
solid handle, 6 mm
mango sólido, 6 mm
poignée massive, 6 mm
solida impugnatura, 6 mm

Füllungsinstrumente

Filling instruments

Instrumentos para obturaciones

Instruments pour plombages

Otturatori



1/1

44-394-07 -
44-396-79

17,5 cm / 6 7/8"

massiver Griff, 6 mm

solid handle, 6 mm

mango sólido, 6 mm

poignée massive, 6 mm

solida impugnatura, 6 mm

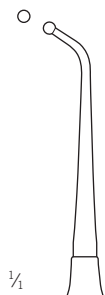

1/1

44-394-07

Fig. 7A

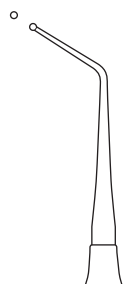

44-394-19

Fig. 19

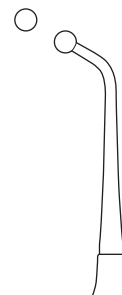

44-394-77

Fig. 7B

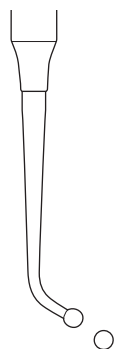

1/1

44-396-06

Fig. 6



44-396-11

Fig. 11

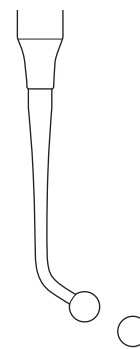

44-396-79

Fig. 179



1/1

44-396-06

Fig. 6



44-396-11

Fig. 11



44-396-79

Fig. 179



Füllungsinstrumente

Filling instruments

Instrumentos para obturaciones

Instrumentes pour plombages

Otturatori

Füllungsinstrumente

Filling instruments

Instrumentos para obturaciones

Instrumentes pour plombages

Otturatori

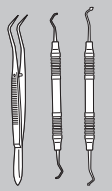

Heidemann
44-398-01 -
44-399-13

17,5 cm / 6 7/8"
massiver Griff, 6 mm
solid handle, 6 mm
mango sólido, 6 mm
poignée massive, 6 mm
solida impugnatura, 6 mm



1/4

44-398-01
Fig. 1
2,0 mm



44-398-02
Fig. 2
2,5 mm



44-398-04
Fig. 3
3 mm



1/4

44-399-11
Fig. 11
2,0 mm

scharf
sharp
afilado
affilé
affilato



44-399-12
Fig. 12
2,5 mm

scharf
sharp
afilado
affilé
affilato



44-399-13
Fig. 13
3,0 mm

scharf
sharp
afilado
affilé
affilato



Mini-Zementspatel

Mini cement mixing spatula

Mini espátula para cemento

Mini spatule à plâtre

Mini spatola per cemento

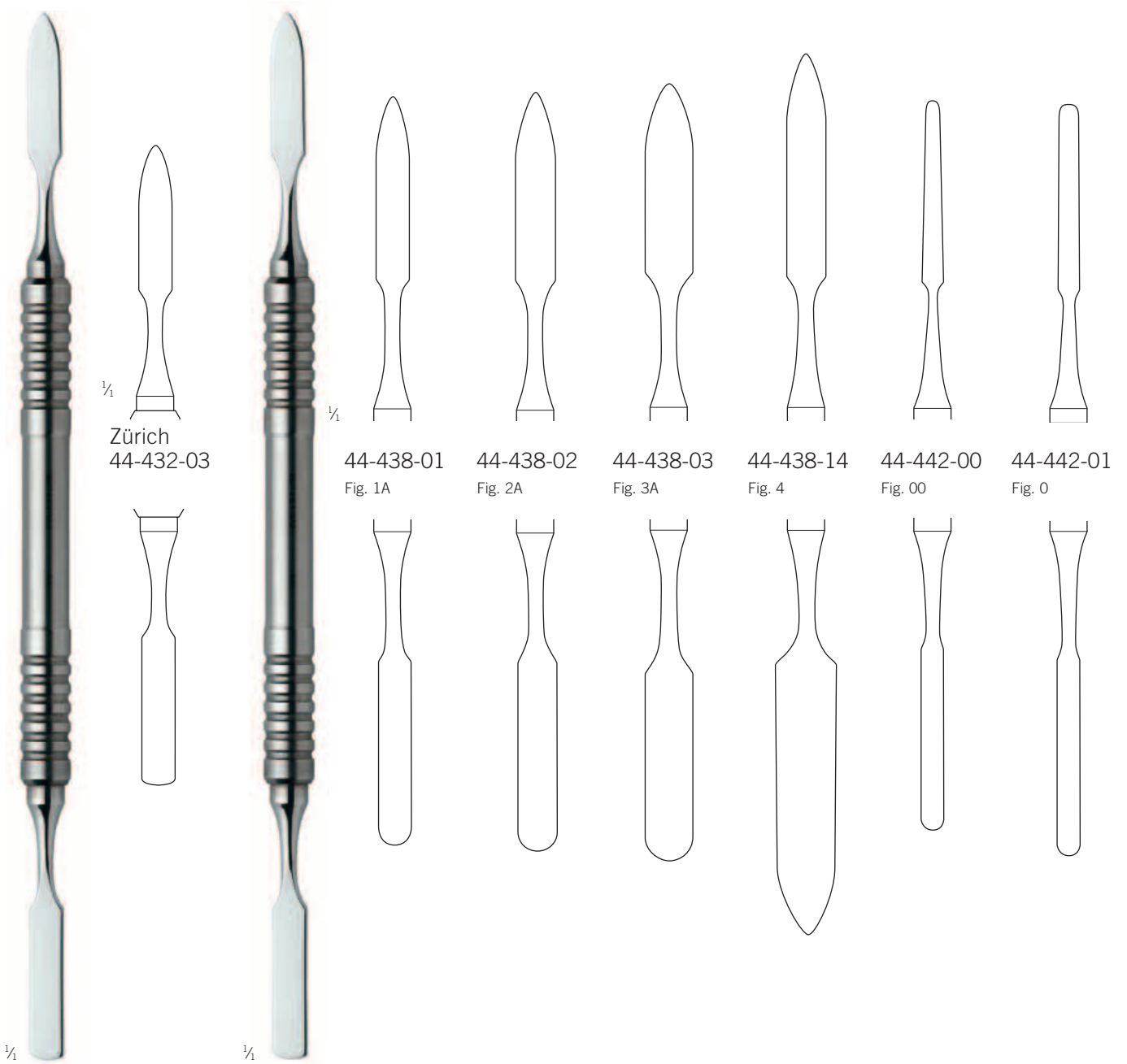

Zürich
44-432-03

17,5 cm / 6 7/8"

Hohlgriff, 8 mm
hollow handle, 8 mm
mango hueco, 8 mm
poignée creuse, 8 mm
manico cavo, 8 mm

44-438-01 - 44-442-01

17,5 cm / 6 7/8"

Hohlgriff, 8 mm
hollow handle, 8 mm
mango hueco, 8 mm
poignée creuse, 8 mm
manico cavo, 8 mm

Zementspatel, Silikatspatel

Cement mixing spatula, silicate mixing spatula

Espátula para mezclar, espátula de silicato

Spatule à plâtre, spatule à silicate

Spatola per cemento, spatola per la mescolatura di silicone

Füllungsinstrumente

Filling instruments

Instrumentos para obturaciones

Instrumentos pour plombages

Otturatori

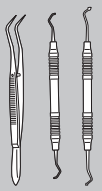

1/1

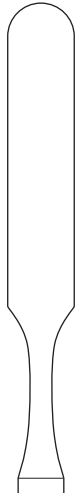

1/1

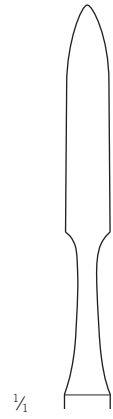

1/1



44-444-02
Fig. 2



44-444-03
Fig. 3

44-444-01
Fig. 1



44-440-02

17 cm / 6 5/8"

massiver Griff, 6 mm
solid handle, 6 mm
mango sólido, 6 mm
poignée massive, 6 mm
solida impugnatura, 6 mm

Martin

44-444-01 - 44-444-03

17,5 cm / 6 7/8"

Zementspatel, 6 mm, massiver Griff
Cement mixing spatula, 6 mm, solid handle
Espátula para cemento, mango sólido de 6 mm
Spatule à plâtre, poignée massive de 6 mm
Spatola per cemento, solida impugnatura da 6 mm



1/2

44-457-01

17,5 cm / 6 7/8"

Silikatspatel, aus Kunststoff
Silicate spatula, plastic
Espátula de silicato, de plástico
Spatule à silicate, en plastique
Spatola di silicone, in plastica

Matrizen und Matrizenspanner

Matrix bands and retainers

Portamatrices y matrices

Porte matrices et matrices

Portamatrici e matrici



1/2

Ivory
44-465-01

Fig. 1



1/2

Ivory
44-467-01

Fig. 12



1/2

Ivory
44-468-01

Fig. 12A



1/2

Ivory
44-480-05 5 mm

44-480-06 6 mm

44-480-07 7 mm

1/4



44-470-01

Fig. 1



44-470-04

Fig. 4



44-470-02

Fig. 2



44-470-05

Fig. 5

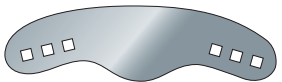

44-470-03

Fig. 3



44-470-06

Fig. 6

für Molaren, 12 Stück
for molars, 12 pieces
para molares, 12 piezas
pour molaires, 12 pièces
per molari, 12 pezzi

für Prämolaren, 12 Stück
for premolars, 12 pieces
para premolares, 12 piezas
pour prémolaires, 12 pièces
per premolari, 12 pezzi

Matrizen und Matrizenspanner

Matrix bands and retainers
 Portamatrices y matrices
 Porte matrices et matrices
 Portamatrici e matrici

Füllungsinstrumente

Filling instruments
 Instrumentos para obturaciones
 Instruments pour plombages
 Otturatori

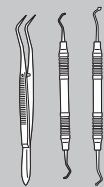

44-481-01
 Junior
 44-481-05
 Universal

Tofflemire
 44-481-01 - 44-481-05

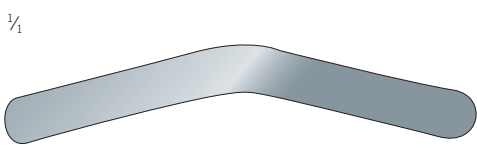

Tofflemire
 44-482-01
 Fig. 1
 12 Stück
 12 pieces
 12 piezas
 12 pièces
 12 pezzi

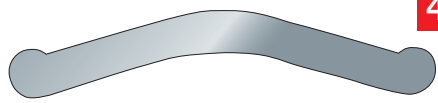

Tofflemire
 44-482-13
 Fig. 13
 12 Stück
 12 pieces
 12 piezas
 12 pièces
 12 pezzi

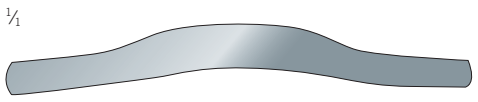

44-484-07
 Fig. 7



44-484-08
 Fig. 8

für Molaren, 12 Stück
 for molars, 12 pieces
 para molares, 12 piezas
 pour molaires, 12 pièces
 per molari, 12 pezzi



44-484-09
 Fig. 9

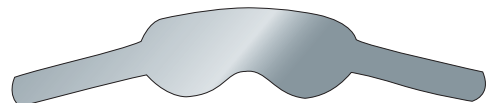

44-484-10
 Fig. 10

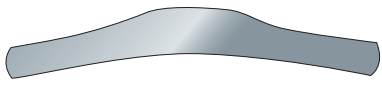

44-484-11
 Fig. 11

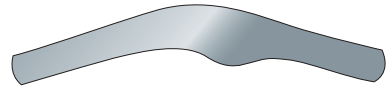

44-484-12
 Fig. 12



44-484-13
 Fig. 13



44-485-05	5 mm x 1 m
44-485-06	6 mm x 1 m
44-485-07	7 mm x 1 m

Kofferdam-Instrumente

Rubber dam instruments

Dique de goma

Instruments kofferdam

Kofferdam



1/2

Ainsworth
44-500-16

16 cm / 6 1/8"

Kofferdam-Lochzange

Punch forceps

Perforadores

Pinces à perforer

Pinze foradiga



1/2

USA
44-502-15

15 cm / 5 7/8"

Kofferdam-Lochzange

Punch forceps

Perforadores

Pinces à perforer

Pinze foradiga



1/2

Ivory
44-506-16

16 cm / 6 1/8"

Kofferdam-Klammerzange

Clamp forceps

Portaclamps

Pinces porte crampons

Pinze per uncini



1/2

Brewer
44-513-17

17 cm / 6 6/8"

Kofferdam-Klammerzange

Clamp forceps

Portaclamps

Pinces porte crampons

Pinze per uncini



1/2

Stockes
44-503-17

17 cm / 6 6/8"

Kofferdam-Klammerzange

Clamp forceps

Portaclamps

Pinces porte crampons

Pinze per uncini

Kofferdam-Instrumente

Rubber dam instruments
 Dique de goma
 Instruments kofferdam
 Kofferdam

Füllungsinstrumente

Filling instruments
 Instrumentos para obturaciones
 Instruments pour plombages
 Otturatori

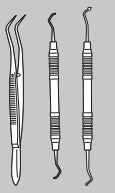

1/2

Wizard
 44-520-00

Fig. 60
 Kofferdam-Halter
 Rubber dam holder
 Sostenedor
 Porte digues
 Supporto per kofferdam



1/4

Ivory	44-515-26 Fig. 26	44-515-27 Fig. 27	44-515-28 Fig. 28	44-515-29 Fig. 29
-------	----------------------	----------------------	----------------------	----------------------



1/4

44-515-30 Fig. 30	44-515-31 Fig. 31	44-515-51 Fig. 51	44-515-60 Fig. 60
----------------------	----------------------	----------------------	----------------------

46

Abdrucklöffel, Modellierinstrumente, Kroneninstrumente

Impression trays, carving instruments, instruments for crown work
Cubetas para impresiones, instrumentos para modelar, instrumentos para coronas
Porte empreintes, instruments à modeler, instruments pour couronnes
Portaimpronte, strumenti per modellare, strumenti per corone

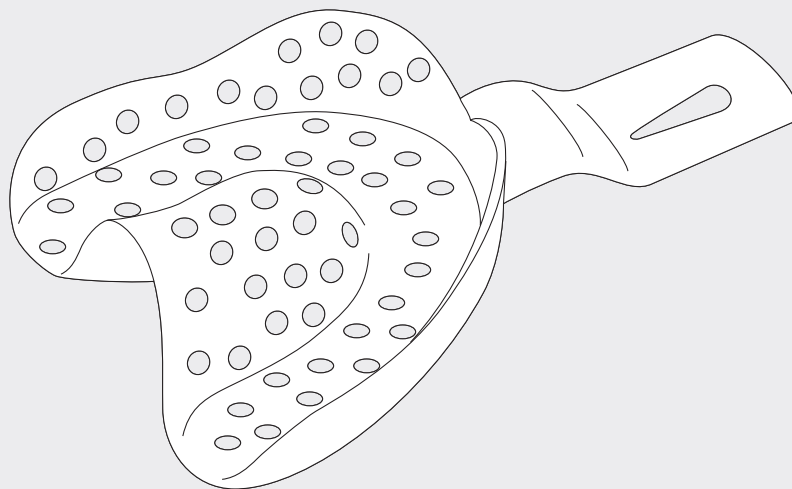

Elite-Abdrucklöffel nach Ehrlicke

Elite impression trays according to Ehrlicke

Elite cubetas para impresiones según Ehrlicke

Porte empreintes selon Ehrlicke

Portaimpronte Ehrlicke



Form BO (SUP/B)

für bezahnte Oberkiefer, gelocht
for toothed upper jaws, perforated
para mandíbulas superiores dentadas, perforadas
maxillaires dentés, perforés
per mascella superiore dentata, perforata

46-101-00	Fig. 0
46-101-01	Fig. 1
46-101-02	Fig. 2
46-101-03	Fig. 3
46-101-04	Fig. 4

Fig. 0 = für Kinder / for children / para niños / pour enfants / per bambini



Form PO (SUP/P)

für partiell bezahnte Oberkiefer, gelocht
for partially toothed upper jaws, perforated
para mandíbulas superiores parcialmente dentadas, perforadas
maxillaires partiellement dentés, perforés
per mascella superiore parzialmente dentata, perforata

46-102-01	Fig. 1
46-102-02	Fig. 2
46-102-03	Fig. 3



Form FO (SUP/F)

für Funktionsabdrücke im Oberkiefer, gelocht
for upper functional impressions, perforated
para impresiones funcionales superiores, perforadas
maxillaires, empreintes fonctionelles, perforés
per impronte funzionali nella mascella superiore dentata, perforata

46-103-01	Fig. 1
46-103-02	Fig. 2
46-103-03	Fig. 3



Form UO (SUP/U)

für unbezahnte Oberkiefer, gelocht
for edentulous upper jaws, perforated
para mandíbulas superiores desdentadas, perforadas
maxillaires édentés, perforés
per mascella superiore edentula, perforata

46-104-01	Fig. 1
46-104-02	Fig. 2
46-104-03	Fig. 3

Elite-Abdrucklöffel nach Ehrlicke

Elite impression trays according to Ehrlicke
Elite cubetas para impresiones según Ehrlicke
Porte empreintes selon Ehrlicke
Portaimpronte Ehrlicke

Abdrucklöffel

Impression trays
Cubetas para impresiones
Porte empreintes
Portaimpronte



Form BU (INF/B)

für bezahnte Unterkiefer, gelocht
for toothed lower jaws, perforated
para mandíbulas inferiores dentadas, perforadas
mandibules dentés, perforés
per mascella inferiore dentata, perforata

46-106-00	Fig. 0
46-106-01	Fig. 1
46-106-02	Fig. 2
46-106-03	Fig. 3
46-106-04	Fig. 4

Fig. 0 = für Kinder / for children / para niños / pour enfants / per bambini

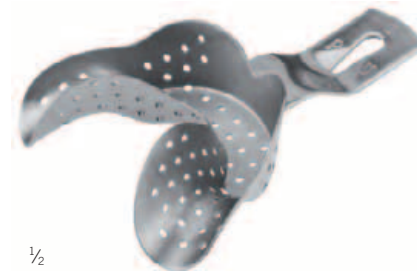

Form PU (INF/P)

für partiell bezahnte Unterkiefer, gelocht
for partially toothed lower jaws, perforated
para mandíbulas inferiores parcialmente dentadas, perforadas
mandibules partiellement dentés, perforés
per mascella inferiore parzialmente dentata, perforata

46-107-01	Fig. 1
46-107-02	Fig. 2
46-107-03	Fig. 3



Form UU (INF/U)

für unbezahnte Unterkiefer, gelocht
for edentulous lower jaws, perforated
para mandíbulas inferiores desdentadas, perforadas
Mandibules édentés, perforés
Per mascella inferiore edentula, perforata

46-108-01	Fig. 1
46-108-02	Fig. 2
46-108-03	Fig. 3



Form BO (SUP/B)

für bezahnte Oberkiefer, ungelocht
for toothed upper jaws, unperforated
para mandíbulas superiores dentadas, no perforadas
maxillaires dentés, non perforés
per mascella superiore dentata, non perforata

46-131-00	Fig. 0
46-131-01	Fig. 1
46-131-02	Fig. 2
46-131-03	Fig. 3
46-131-04	Fig. 4

Fig. 0 = für Kinder / for children / para niños / pour enfants / per bambini

Elite-Abdrucklöffel nach Ehrlicke

Elite impression trays according to Ehrlicke

Elite cubetas para impresiones según Ehrlicke

Porte empreintes selon Ehrlicke

Portaimpronte Ehrlicke



1/2

Form PO (SUP/P)

für partiell bezahnte Oberkiefer, ungelocht
for partially toothed upper jaws, unperforated
para mandíbulas superiores parcialmente dentadas, no perforadas
maxillaires partiellement dentés, non perforés
per mascella superiore parzialmente dentata, non perforata

46-132-01	Fig. 1
46-132-02	Fig. 2
46-132-03	Fig. 3



1/2

Form FO (SUP/F)

für Funktionsabdrücke oben, ungelocht
for upper functional impressions, unperforated
para impresiones funcionales superiores, no perforadas
maxillaires, empreintes fonctionnelles, non perforés
per impronte funzionali in alto, non perforate

46-133-01	Fig. 1
46-133-02	Fig. 2
46-133-03	Fig. 3



1/2

Form UO (SUP/U)

für unbezahnte Oberkiefer, ungelocht
for edentulous upper jaws, unperforated
para mandíbulas desdentadas superiores, no perforadas
maxillaires édentés, non perforés
per mascella superiore edentula, non perforata

46-134-01	Fig. 1
46-134-02	Fig. 2
46-134-03	Fig. 3



1/2

Form BU, Fig. 0 (INF/B)

für bezahnte Unterkiefer, ungelocht
for toothed lower jaws, unperforated
para mandíbulas inferiores dentadas, no perforadas
mandibules dentés, non perforés
per mascella inferiore dentata, non perforata

46-136-00	Fig. 0
46-136-01	Fig. 1
46-136-02	Fig. 2
46-136-03	Fig. 3
46-136-04	Fig. 4

Fig. 0 = für Kinder / for children / para niños / pour enfants / per bambini

Elite-Abdrucklöffel nach Ehrlicke

Elite impression trays according to Ehrlicke
Elite cubetas para impresiones según Ehrlicke
Porte empreintes selon Ehrlicke
Portaimpronte Ehrlicke

Abdrucklöffel

Impression trays
Cubetas para impresiones
Porte empreintes
Portaimpronte

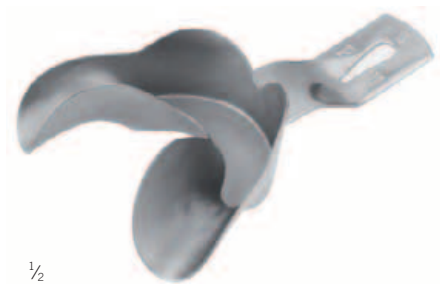
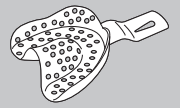

1/2

Form PU (INF/P)

für partiell bezahnte Unterkiefer, ungelocht
for partially toothed lower jaws, unperforated
para mandíbulas inferiores parcialmente dentadas, no perforadas
mandibules partiellement dentés, non perforés
per mascella inferiore parzialmente non dentata, non perforata

46-137-01	Fig. 1
46-137-02	Fig. 2
46-137-03	Fig. 3



1/2

Form UU (INF/U)

für unbezahnte Unterkiefer, ungelocht
for edentulous lower jaws, unperforated
para mandíbulas inferiores desdentadas, no perforadas
mandibules édentés, non perforés
per mascella inferiore edentula, non perforata

46-138-01	Fig. 1
46-138-02	Fig. 2
46-138-03	Fig. 3

Abdrucklöffel für partielle Abdrücke

Impression trays for partial impressions

Cubetas para impresiones parciales

Porte empreintes partiels

Portaimpronte parziali



½

Form C1/2R

gelocht
perforated
perforado
perforé
perforato

46-151-01	Fig. 1
46-151-02	Fig. 2
46-151-03	Fig. 3



½

Form C1/2R

ungelocht
unperforated
no perforado
non perforé
non perforato

46-152-11	Fig. 1
46-152-12	Fig. 2
46-152-13	Fig. 3



½

Form C1/2L

gelocht
perforated
perforado
perforé
perforato

46-161-01	Fig. 1
46-161-02	Fig. 2
46-161-03	Fig. 3



½

Form C1/2L

ungelocht
unperforated
no perforado
non perforé
non perforato

46-162-11	Fig. 1
46-162-12	Fig. 2
46-162-13	Fig. 3



½

46-171-01

mit drehbarem Griff und Stellschraube
with swivel handle and fixing screw
con mango giratorio y tornillo de sujeción
avec poignée pivotante et vis de blocage
con impugnatura girevole e vite di regolazione

gelocht
perforated
perforado
perforé
perforato



½

46-172-11

gelocht
perforated
perforado
perforé
perforato



½

46-175-01

mit drehbarem Griff
with swivel handle
con mango giratorio
avec poignée pivotante
con impugnatura girevole

gelocht
perforated
perforado
perforé
perforato



½

46-176-11

mit drehbarem Griff
with swivel handle
con mango giratorio
avec poignée pivotante
con impugnatura girevole

ungelocht
unperforated
no perforado
non perforé
non perforato

Abdrucklöffel für partielle Abdrücke

Impression trays for partial impressions

Cubetas para impresiones parciales

Porte empreintes partiels

Portaimpronte parziali

Abdrucklöffel

Impression trays

Cubetas para impresiones

Porte empreintes

Portaimpronte



1/2



Stolley
46-181-01

mit drehbarem Griff und Fixierschieber
with swivel handle and slide
con mango giratorio y cierre corredizo
avec poignée pivotante et curseur de fixation
con impugnatura girevole e cursore di fissaggio

gelocht
perforated
perforado
perforé
perforato



1/2

Stolley
46-182-11

ungelocht
unperforated
no perforado
non perforé
non perforato

Spatel / Fadenstopfer

Spatulas / gingival cord packer

Espátulas / instrumentos para hilo retractor

Spatules / instruments pour fil retracteur

Spatole / strumenti per fili di retrazione



46-185-02

17,5 cm / 6 7/8"

Fig. 2

massiver Griff, 6 mm
solid handle, 6 mm
mango sólido, 6 mm
poignée massive, 6 mm
manico cavo, 6 mm



46-185-02

17,5 cm / 6 7/8"

Fig. 2

massiver Griff, 6 mm
solid handle, 6 mm
mango sólido, 6 mm
poignée massive, 6 mm
manico cavo, 6 mm



Schwarz

46-280-17

17 cm / 6 6/8"

Plexiglas
plexiglass
plexiglás
plexiglas
plexiglas



Lichtenstein

46-288-17

17 cm / 6 6/8"

Weichgummi, Kunststoff

Soft rubber, plastic
Goma blanda, plástico
Caoutchouc mou, plastique
Gomma morbida, plastica

Modellierinstrumente

Carving instruments
Instrumentos para modelar
Instruments à modeler
Strumenti per modellare

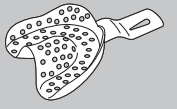

46



½

46-320-13

130 mm

Weichgummi
soft rubber
goma blanda
caoutchouc mou
gomma morbida



½

46-321-13

130 mm

Kunststoff
plastic
plástico
plastique
plastica

Wachs-, Porzellan- und Modellierinstrumente

Wax, porcelain and modelling carvers

Talladores y espátulas para cera, porcelana y modelar

Instruments à modeler

Strumenti per modellare

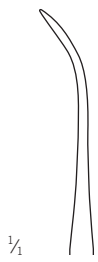

46-342-01
Fig. 1



46-342-02
Fig. 2



46-342-03
Fig. 3



46-342-04
Fig. 4



46-342-05
Fig. 5

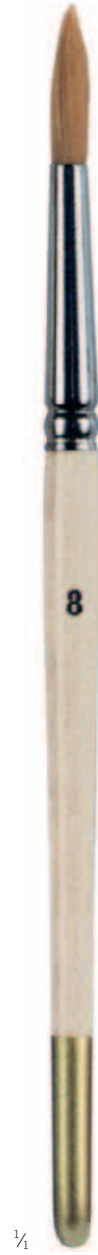

46-342-90

Fig. 90

Wachspinsel
wax brush
pincel de cera
pinceau à cire
pennello per cera

Thomas
46-342-01 - 46-342-05

17,5 cm / 6 7/8"

massiver Griff, 6 mm
solid handle, 6 mm
mango sólido, 6 mm
poignée massive, 6 mm
solida impugnatura, 6 mm

Wachs-, Porzellan- und Modellierinstrumente

Wax, porcelain and modelling carvers
 Talladores y espátulas para cera, porcelana y modelar
 Instruments à modeler
 Strumenti per modellare

Parodontologie

Periodontology
 Parodontología
 Parodontologie
 Parodontologia

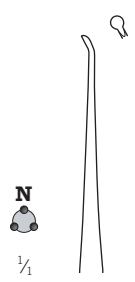
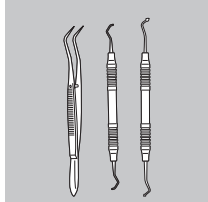

Zürich
46-361-02



Mercury
46-362-01
Fig. 1

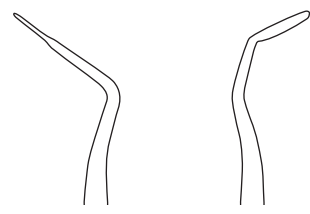

46-362-02
USC, Fig. 2



46-362-03
Fig. 104



Mikroschnitzer, zum Abtragen von überschüssigem Füllungsmaterial bei WSR

Micro carver, for removing superfluous filling material (apicoectomy)

Micro tallador, para resecar material de empaste superfluo en la apicectomía

Micro sculpteur, pour enlever le matériau de remplissage superflu lors de la résection de l'apex

Micro intagliatore, per l'asportazione di materiale di otturazione superfluo per l'apicectomia

1/4

46-361-02 -
46-362-03

17,5 cm / 6 7/8"

massiver Griff, 6 mm
 solid handle, 6 mm
 mango sólido, 6 mm
 poignée massive, 6 mm
 solida impugnatura, 6 mm



GR = grau
 grey
 gris
 gris
 grigio



Y = gelb
 yellow
 amarillo
 jaune
 giallo



R = rot
 red
 rojo
 rouge
 rosso



G = grün
 green
 verde
 vert
 verde



V = violett
 violet
 violeta
 violet
 viola



W = weiß
 white
 blanco
 blanc
 bianco



B = blau
 blue
 azur
 bleu
 blu



N = schwarz
 black
 negro
 noir
 nero

Wachs-, Porzellan- und Modellierinstrumente

Wax, porcelain and modelling carvers

Talladores y espátulas para cera, porcelana y modelar

Instruments à modeler

Strumenti per modellare



Hollenback
46-363-01
Fig. 1/2



Hollenback
46-363-02
Fig. 3



Hollenback
46-363-03
Fig. 3S



Frahm
46-364-01
Fig. 0/1



Frahm
46-364-02
Fig. 2/3



Ward
46-365-01
Fig. 1

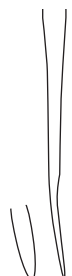

¼

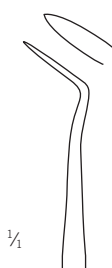

Ward
46-365-02
Fig. 1S



Ward
46-365-03
Fig. 2



Nyström
46-366-01
Fig. 1



Nyström
46-366-02
Fig. 2



Nyström
46-366-03
Fig. 3

46-363-01 -
46-366-03
17,5 cm / 6 7/8"

massiver Griff, 6 mm
solid handle, 6 mm
mango sólido, 6 mm
poignée massive, 6 mm
solida impugnatura, 6 mm

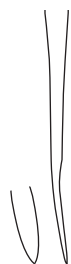

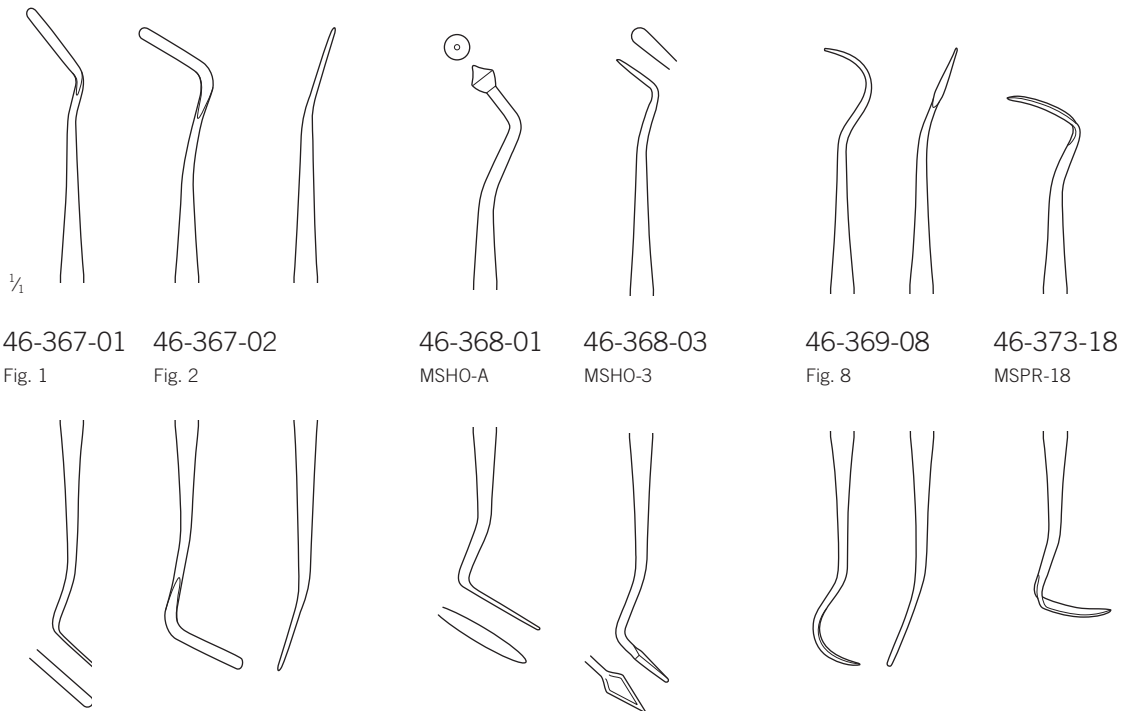
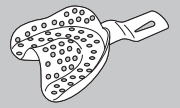

46-367-01
Fig. 1

46-367-02
Fig. 2

46-368-01
MSHO-A

46-368-03
MSHO-3

46-369-08
Fig. 8

46-373-18
MSPR-18

für interdental Anwendungen
for interdental applications
para aplicaciones interdenciales
pour applications interdentaires
per applicazioni interdentali

46-367-01 -
46-373-18

17,5 cm / 6 7/8"

massiver Griff, 6 mm
solid handle, 6 mm
mango sólido, 6 mm
poignée massive, 6 mm
solida impugnatura, 6 mm

Wachs-, Porzellan- und Modellierinstrumente

Wax, porcelain and modelling carvers

Talladores y espátulas para cera, porcelana y modelar

Instruments à modeler

Strumenti per modellare

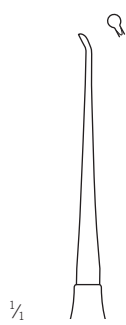

46-374-00
C/D Fig. 0

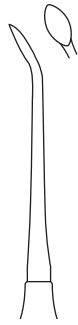

46-374-05
C/D Fig. 4/5

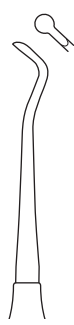

46-374-06
C/D Fig. 3/6



46-374-07
C/D Fig. 4/7



46-374-92
C/D Fig. 89/92



374-99
Fig. 110

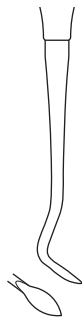

46-374-00 -
46-374-99

17,5 cm / 6 7/8"

massiver Griff, 6 mm

solid handle, 6 mm

mango sólido, 6 mm

poignée massive, 6 mm

solida impugnatura, 6 mm

Wachs-, Porzellan- und Modellierinstrumente

Wax, porcelain and modelling carvers
Talladores y espátulas para cera, porcelana y modelar
Instruments à modeler
Strumenti per modellare

Modellierinstrumente

Carving instruments
Instrumentos para modelar
Instruments à modeler
Strumenti per modellare

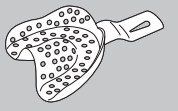

Hylin
46-392-02



Zahle
46-394-02



Le Cron
46-401-02
Fig. 1



Beale
46-462-02
Fig. 1

Wachs-, Porzellan- und Modellierinstrumente

Wax, porcelain and modelling carvers

Talladores y espátulas para cera, porcelana y modelar

Instruments à modeler

Strumenti per modellare

AI



Greenstein
46-470-01

Fig. 1

18 cm / 7 1/8"

Rundgriff, 8 mm
round handle, 8 mm
mango redondo, 8 mm
poignée ronde, 8 mm
impugnatura rotonda, 8 mm

erhältlich zu 3 Stück
available in 3 piece packs
disponible en emballages de 3 piezas
disponible en paquet de 3 unités
disponibile in confezioni da 3 pezzi

für Keramik
for ceramics
para cerámica
pour céramique
per ceramica

Wachs-, Porzellan- und Modellierinstrumente

Wax, porcelain and modelling carvers

Talladores y espátulas para cera, porcelana y modelar

Instruments à modeler

Strumenti per modellare

Modellierinstrumente

Carving instruments

Instrumentos para modelar

Instruments à modeler

Strumenti per modellare

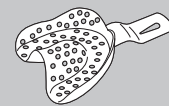

AI



Greenstein
46-470-02

Fig. 2

18 cm / 7 1/8"

Rundgriff, 8 mm
round handle, 8 mm
mango redondo, 8 mm
poignée ronde, 8 mm
impugnatura rotonda, 8 mm

erhältlich zu 3 Stück
available in 3 piece packs
disponible en embalajes de 3 piezas
disponible en paquet de 3 unités
disponibile in confezioni da 3 pezzi

für Keramik
for ceramics
para cerámica
pour céramique
per ceramica

Wachs-, Porzellan- und Modellierinstrumente / Kroneninstrumente

Wax, porcelain and modelling carvers / Instruments for crown work

Talladores y espátulas para cera, porcelana y modelar / Instrumentos para coronas

Instruments à modeler / Instruments de couronnes

Strumenti per modellare / Strumenti per corone



Gisy-Wild
46-480-15

15 cm / 6"

Wachsmesser
Wax knife
Cuchillo para cera
Couteau à cire
Coltello per cera



Gritmann
46-481-17

Gipsmesser
Plaster knife
Cuchillo para yeso
Couteau à plâtre
Coltello per gesso



46-482-13

13 cm / 5"

46-482-17

17 cm / 6 1/4"

Fahnenstock
46-482-13 - 46-482-17

Wachsmesser
Wax knife
Cuchillo para cera
Couteau à cire
Coltello per gesso



Miller
46-517-15

15 cm / 6"

Artikulationspapier-Pinzetten
Articulating paper forceps
Pinzas para papel de articulación
Pincettes à papier d'articulation
Pinzette per carta di articolazione



Miller
46-518-15

15 cm / 6"



Sachs
46-520-01

Kronensetzer
Crown setter
Fijador de coronas
Ajusteur de couronne
Fissatore per corona
Plexiglas
plexiglass
plexiglás
plexiglas
plexiglas



Mershon
46-528-01

Bandtreiber
Band pusher
Ajustador de bandas
Ajusteur de bande
Dispositivo di azionamento del nastro



46-530-01

Kronensetzer
Crown setter
Fijador de coronas
Ajusteur de couronne
Fissatore per corona
Edelstahl
stainless steel
acero inoxidable
acier inoxydable
acciaio inossidabile



Paris
46-546-01

16 cm / 6 1/8"

Dentimeter
Dentimeter
Dentímetro
Dentimètre
Dentimetro



Treyemann
46-578-02

Kronenabnehmer (Hirtenstab)
Crown remover
Extractor de coronas
Extracteur de couronne
Estrattore per corona

Kroneninstrumente

Instruments for crown work
Instrumentos para coronas
Instruments de couronnes
Strumenti per corone

Kroneninstrumente

Instruments for crown work
Instrumentos para coronas
Instruments pour couronnes
Strumenti per corone

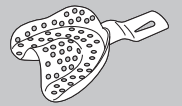

1/2

Crown-Butler
46-582-01

Fig. 1
mit 3 Einsätzen
with 3 inserts
con 3 piezas de inserción
avec 3 inserts
con 3 inserti

46



1/2

Crown-Butler
46-583-00

Fig. 2

incl. 46-583-01
46-583-02
46-583-03



1/2

Crown-Butler
46-583-01

Fig. 1A

Einsatz für Crown-Butler, Fig. 1 + 2
Insert for Crown-Butler, Fig. 1 + 2
Pieza de inserción para el Crown-Butler, Fig. 1 + 2
Insert pour Crown-Butler, Fig. 1 + 2
Inserto per Crown-Butler, Fig. 1 + 2



1/2

Crown-Butler
46-583-02

Fig. 2A



1/2

Crown-Butler
46-583-03

Fig. 3A

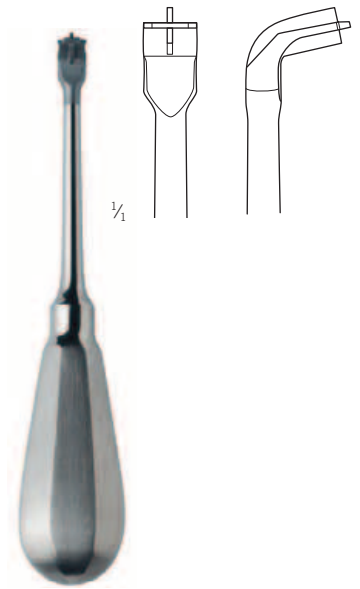

1/4

1/2

46-593-00

Kronenaufbieger
Crown spreader
Alicates extendedores de coronas
Releveur de couronne
Estensore per corona

Kroneninstrumente

Instruments for crown work

Instrumentos para coronas

Instruments de couronnes

Strumenti per corone



1/2



1/1



1/2



1/2

DIAMANT 46-595-13

incl. 46-596-00 + 46-597-00

Teleskopkronenzange mit auswechselbaren
Diamant-Einsätzen

Telescopic crown pliers with exchangeable
diamond inserts

Alicates telescópicos para coronas con piezas
de inserción de diamante intercambiables

Pince télescopique à couronnes avec inserts en
diamant interchangeables

Pinzette telescopiche per corona con inserti in
diamante intercambiabili

46-596-00

Diamanteinsätze für
Teleskopkronenzange

Diamond inserts for
telescopic crown pliers

Piezas de inserción de
diamante para alicates
telescópicos para coronas

Inserts en diamant pour
la pince télescopique à
couronne

Inserti di diamante per
pinzette telescopiche per
corone

46-597-00

Inbusschlüssel für
Teleskopkronenzange

Hex key for telescopic crown
pliers

Llave hexagonal para
alicates telescópicos
para coronas

Clé mâle coudée pour
la pince télescopique à
couronne

Pinzette telescopiche
per corone

46-599-13

Standard

Teleskopkronenzange
Telescopic crown pliers
Alicates telescópicos para coronas
Pince télescopique à couronnes
Pinzette telescopiche per coronas



46-595-13



46-595-13

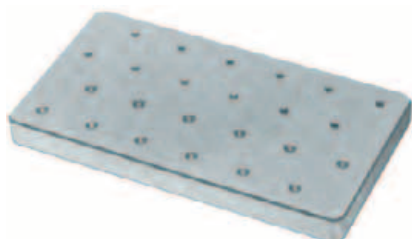

Schön 46-655-00

für 24 Bohrer, für Hand- und Winkelstücke
for 24 burrs/drill bits, for handpieces and angle pieces
para 24 brocas, para piezas manuales y acodadas
pour 24 forets, pour pièces à main et pièces coudées
par 24 punte da trapano, per pezzi manuali e angolari

47

Technikzangen

Technic pliers
Alicates para técnica
Pinces pour technique
Tenaglie per tecnica

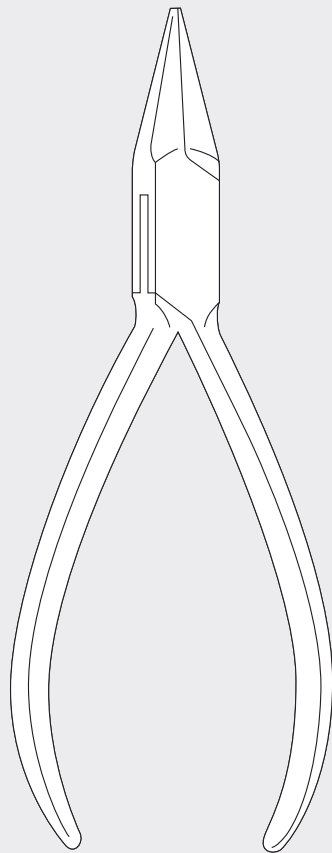

Drahtscheren

Wire cutting scissors

Tijeras para alambre

Cisailles à fils

Forbici per filo metallico

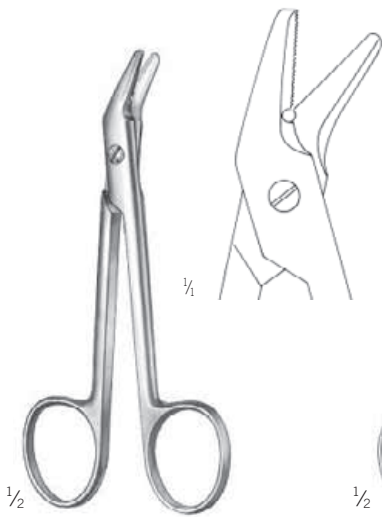

1/2

Universal
11-865-12

12 cm / 4 5/8"
gezahnt
toothed
dentada
dentelée
dentata

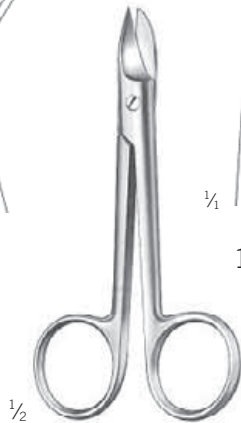

1/2

Beebee
11-874-10 – 11-879-12

10,5 cm / 4 1/8"

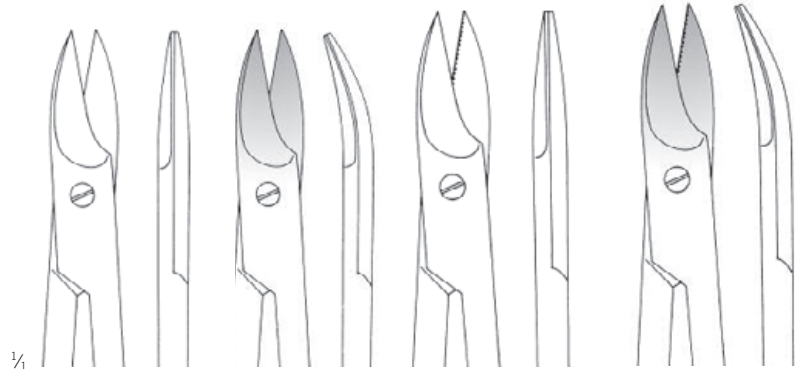

1/4

11-874-10

11-875-10

11-878-12

11-879-12

eine Schneide gezahnt
one toothed cutting edge
una hoja dentada
une lame dentelée
una lama dentata

eine Schneide gezahnt
one toothed cutting edge
una hoja dentada
une lame dentelée
una lama dentata

TC GOLD



1/2

Universal
11-995-12

12,5 cm / 4 7/8"

Drahtschere, eine Schneide gezahnt
Wire cutting scissors, one toothed cutting edge
Tijera para alambre, una hoja dentada
Ciseaux à fils, une lame dentelée
Forbici per fili, una lama dentata

TC GOLD

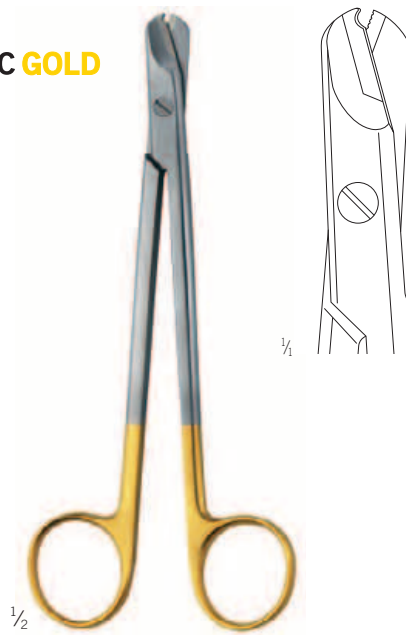

1/2

Martin
11-996-16

16 cm / 6 1/8"

Drahtschere
Wire cutting scissors
Tijera para alambre
Ciseaux à fils
Forbici per fili

Drahtzwirbelzangen

Wire twisting forceps
Pinzas para torcer alambre
Pincas à torsader le fil
Pinze per ritorcere fili

Technikzangen

Technic pliers
Alicates para técnica
Pincas pour technique
Tenaglie per tecnica

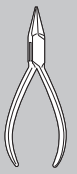

TC GOLD



Martin
22-500-01
15,5 cm / 5 1/8"



22-500-15
15,5 cm / 5 1/8"



22-501-15
15,5 cm / 5 1/8"

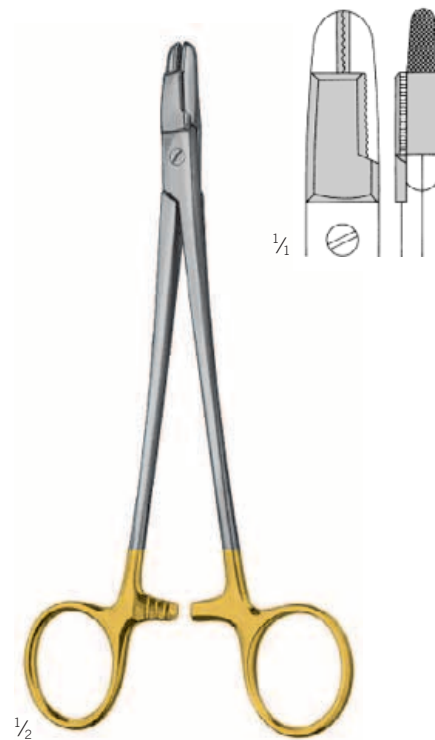

Martin
22-502-18
18,5 cm / 7 2/8"
Kombi-Drahtzwirbelzange
Combi wire twisting forceps
Combi pinza de alambre
Combi pince à torsader le fil
Combi pinza per ritorcere fili

Rund-, Flachzange

Flat nose pliers

Alicates de pico plano

Pinces plates, rondes

Tenaglie piatte

TC GOLD



1/2

22-511-01

18 cm / 7 1/8"

parallel fassend
parallel grip
acción paralela
action parallèle
afferramento parallelo



1/2

22-516-18

18 cm / 7 1/8"

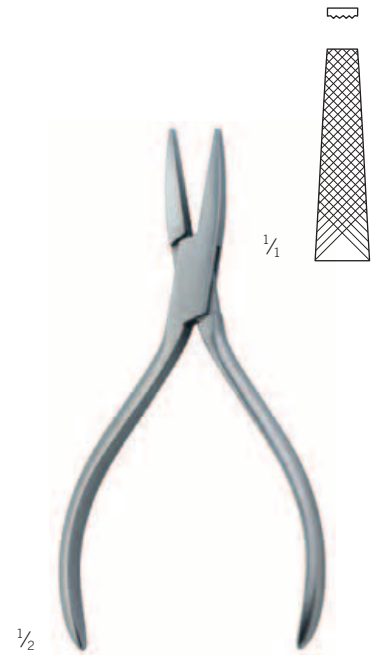

1/2

47-505-14

14,5 cm / 5 6/8"

5 mm, gerieft
5 mm, fluted
5 mm, acanalado
5 mm, cannelé
5 mm, scanalato

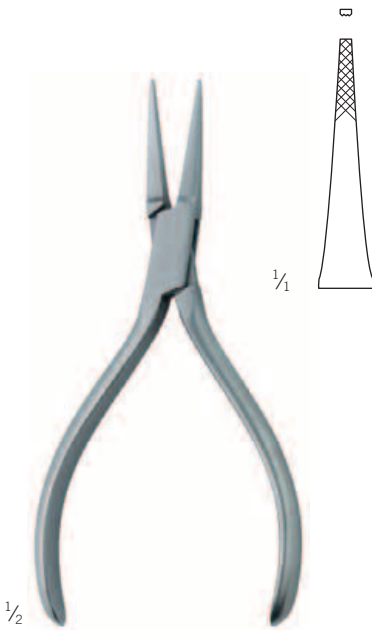

1/2

47-518-14

14,5 cm / 5 6/8"

schmal, gerieft
narrow, fluted
estrecho, acanalado
étroit, cannelé
sottile, scanalato

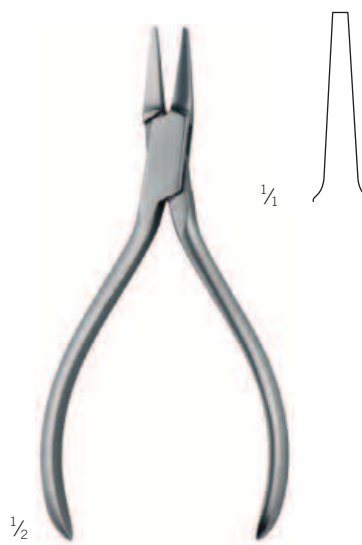

1/2

47-521-13

13 cm / 5 1/8"

glatt
smooth
liso
lisse
liscio

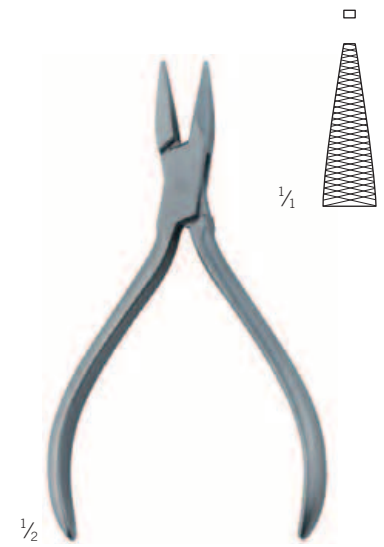

1/2

47-522-13

13 cm / 5 1/8"

gerieft
fluted
acanalado
cannelé
scanalato

Rund-, Flachzange

Flat nose pliers
 Alicates de pico plano
 Pinces plates, rondes
 Tenaglie piatte

Technikzangen

Technic pliers
 Alicates para técnica
 Pinces pour technique
 Tenaglie per tecnica

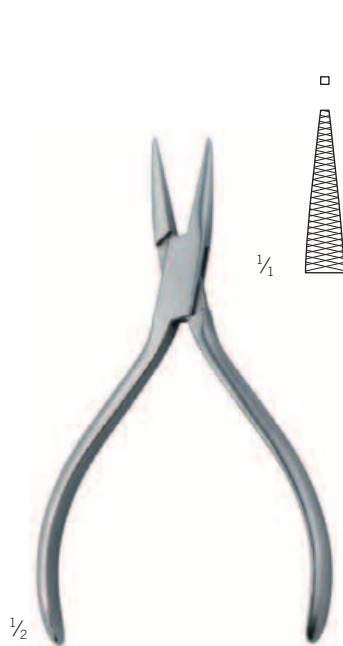
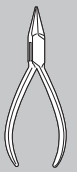

Goslee
 47-524-14
 14,5 cm / 5 7/8"
 Konturenzange
 Contouring pliers
 Alicates para contornear
 Pinces à contours
 Tenaglie per profili

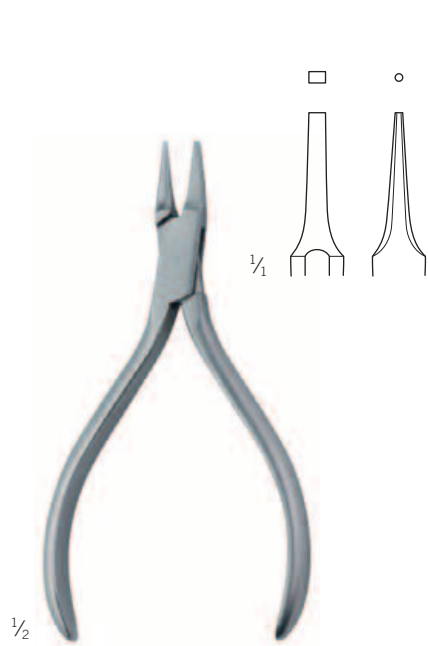

47-538-15
 15 cm / 5 7/8"

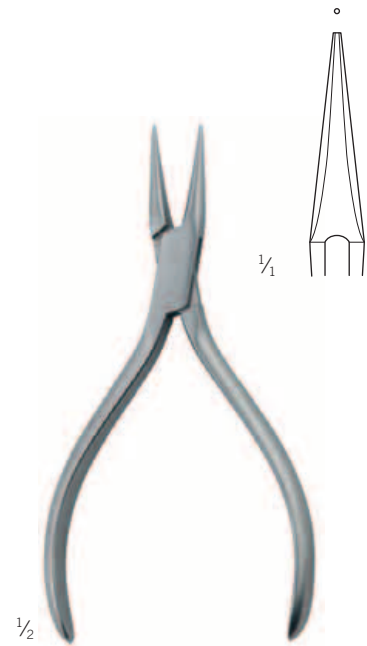

Kopfschneider
 Wire cutter, front action
 Alicates frontal para cortar alambre
 Pinces coupantes frontales
 Tenaglie tagliafili frontali
 47-540-13
 13 cm / 5 1/8"
 fein
 delicado
 fin
 fine

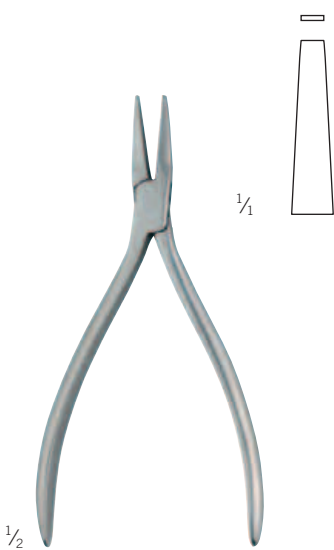

Dumont
 47-554-11
 11,5 cm / 4 4/8"

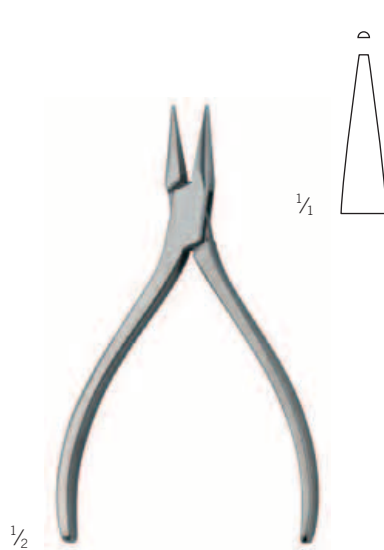

Dumont
 47-555-11
 11,5 cm / 4 4/8"

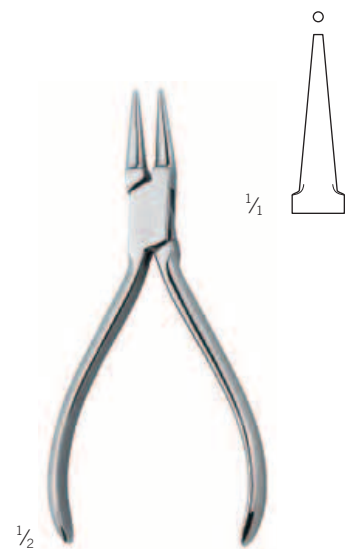

Dumont
 47-556-11
 11,5 cm / 4 4/8"

Drahtkneifzangen, Seitenschneider

Wire cutting pliers

Alicates para cortar alambre, tenazas de corte lateral

Pinces à couper le fil, pinces coupantes de côté

Tenaglie tagliafilii, tenaglie tagliafilii laterali

TC GOLD



für weiche Drähte bis
for soft wires up to
para alambres blandos hasta
pour fils mous jusqu'à
per fili molli fino a
2,0 mm Ø

für harte Drähte bis
for hard wires up to
para alambres duros hasta
pour fils durs jusqu'à
per fili metallici duri fino a
1,7 mm Ø

22-523-16
17 cm / 6 $\frac{5}{8}$ "

TC GOLD



für weiche Drähte bis
for soft wires up to
para alambres blandos hasta
pour fils mous jusqu'à
per fili molli fino a
2,0 mm Ø

für harte Drähte bis
for hard wires up to
para alambres duros hasta
pour fils durs jusqu'à
per fili metallici duri fino a
1,2 mm Ø

22-524-15
15 cm / 5 $\frac{7}{8}$ "

TC GOLD



für weiche Drähte bis
for soft wires up to
para alambres blandos hasta
pour fils mous jusqu'à
per fili molli fino a
2,0 mm Ø

für harte Drähte bis
for hard wires up to
para alambres duros hasta
pour fils durs jusqu'à
per fili metallici duri fino a
1,5 mm Ø

22-526-18
17,5 cm / 6 $\frac{7}{8}$ "

Kopf- und Seitenschneider
Wire cutting plier
Alicate para cortar alambre
Pince pour couper le fil
Tenaglia tagliafilii

Zwickzangen, Bügelbiegezaugen

End and side nippers, bar bending pliers
Alicates cortantes y alicates para doblar alambres
Pincers, pincers à courber les branches
Tenaglie, tenaglie per la piegatura di staffe

Technikzangen

Technic pliers
Alicates para técnica
Pincers pour technique
Tenaglie per tecnica

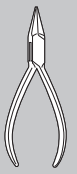

47-562-12
12,5 cm / 4 7/8"



47-563-11
11 cm / 4 3/8"

47

TC GOLD



47-572-11
11 cm / 4 3/8"

TC GOLD

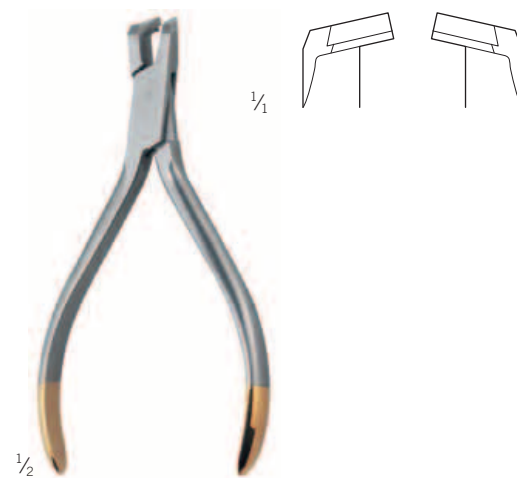

47-580-01
12 cm / 4 6/8"
Distalschneider
Distal cutter
Alicate para cortar alambres
Pince coupeur distale
Pinza per tagliare filo

Zwickzangen, Bügelbiegeezangen

End and side nippers, bar bending pliers
Alicates cortantes y alicates para doblar alambres
Pincès, pincès à courber les branches
Tenaglie, tenaglie per la piegatura di staffe

TC GOLD



47-582-11

11,5 cm / 4 4/8"

Drahtschneidezange
Wire cutter, front action
Alicate para cortar alambres
Pince coupante
Pinza per tagliare filo

TC GOLD



47-582-13

13 cm / 5 1/8"

Drahtschneidezange
Wire cutter, front action
Alicate para cortar alambres
Pince coupante
Pinza per tagliare filo

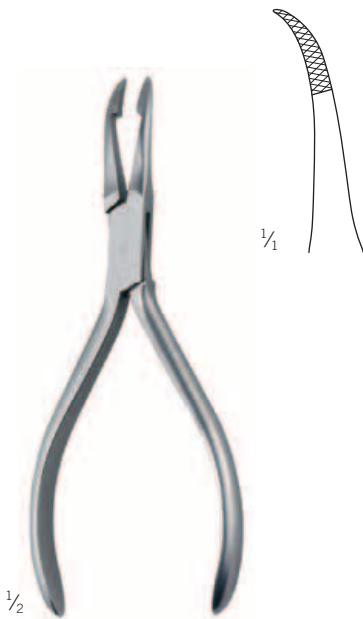

Weingart
47-583-01

12,5 cm / 4 7/8"

Zahntechnikzange
Pliers for dental technic
Pinza de técnica
Pince pour technique
Pinza per tecnica



Aderer
47-584-01

14 cm / 5 4/8"

Bandentfernungs-
zange
Band removing pliers
Alicate para sacar bandas
Pince à bagues
Pinza per levare bande

TEFLON

Zwickzangen, Bügelbiegezangen

End and side nippers, bar bending pliers
Alicates cortantes y alicates para doblar alambres
Pincès, pincès à courber les branches
Tenaglie, tenaglie per la piegatura di staffe

Technikzangen

Technic pliers
Alicates para técnica
Pincès pour technique
Tenaglie per tecnica

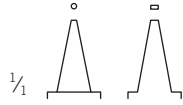
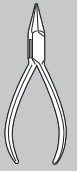

1/2

Angle

47-585-01

12 cm / 4 5/8"

Drahtbiegezange
Wire bending pliers
Alicate para doblar alambres
Pince pour technique
Pinza tecnica per filo

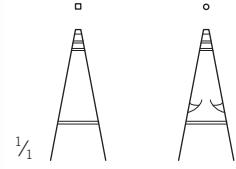

1/2

47-585-02

14 cm / 5 4/8"

Drahtbiegezange
Wire bending pliers
Alicate para doblar alambres
Pince pour technique
Pinza tecnica per filo

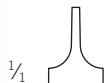

1/2

Tweed

47-585-03

12,5 cm / 4 7/8"

Drahtbiegezange
Wire bending pliers
Pinza de técnica
Pince pour technique
Pinza tecnica per filo



1/2

47-586-01

12 cm / 4 5/8"

Bügelbiegezange
Clasps bending pliers
Alicate para barras
Pince à courber des crochets
Pinza tecnica per piegare forma arco

Zwickzangen, Bügelbiegezangen

End and side nippers, bar bending pliers

Alicates cortantes y alicates para doblar alambres

Pinces, pinces à courber les branches

Tenaglie, tenaglie per la piegatura di staffe

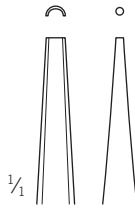

Fig. 1

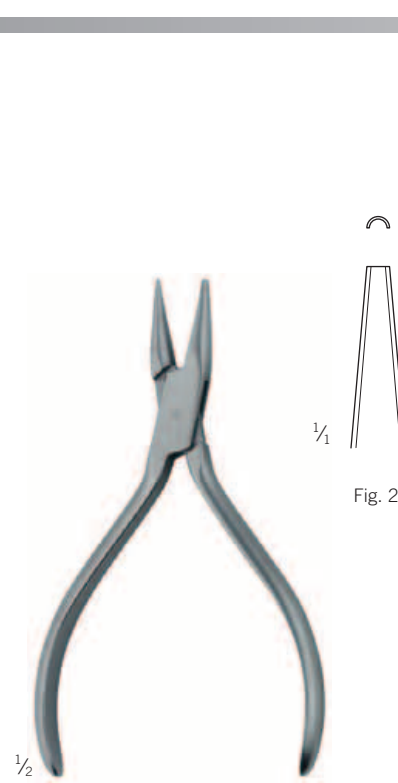

Fig. 2

Schwarz
47-604-13
13 cm / 5 1/8"

Schwarz
47-606-13
13 cm / 5 1/8"

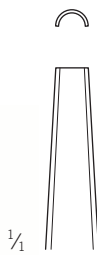
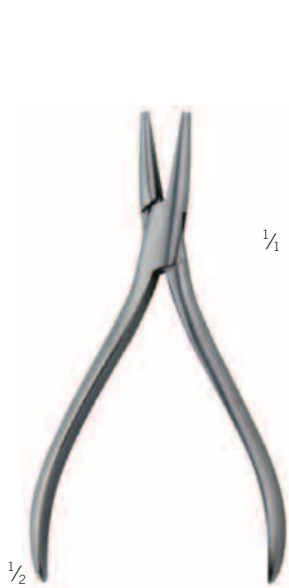

Fig. 3

Schwarz
47-608-13
13 cm / 5 1/8"

Draht-, Bogen- und Klammernbiegeezangen

Wire, arch and clasp bending pliers

Alicates para doblar alambres, arcos y ganchos

Pinces à courber les fils, les branches et les agrafes

Tenaglie per la piegatura di fili metallici, staffe e graffe

Technikzangen

Technic pliers

Alicates para técnica

Pinces pour technique

Tenaglie per tecnica

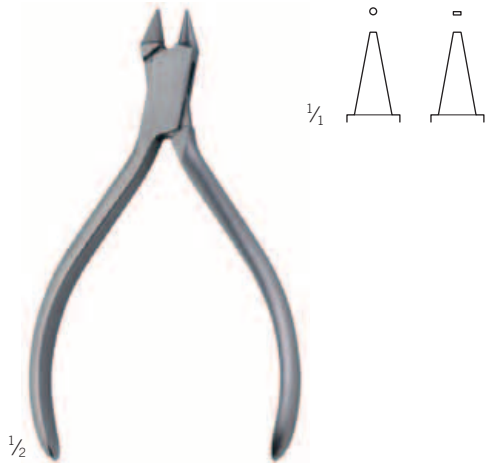
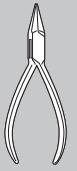

Angle
47-650-12
12 cm / 4 9/16"

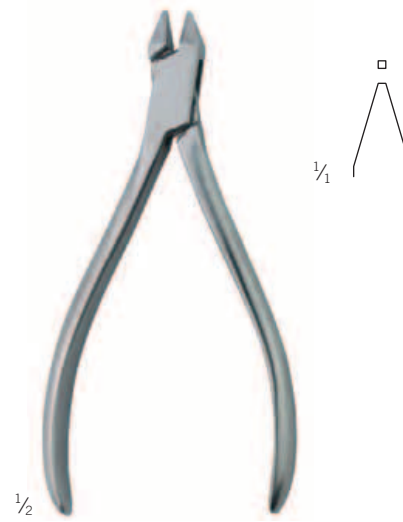

Adams
47-654-13
13 cm / 5 1/8"

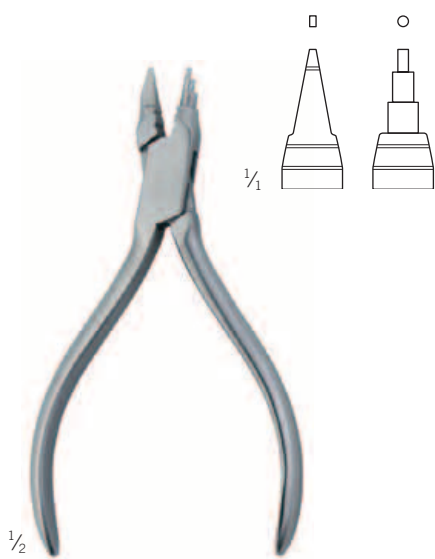

Young
47-660-13
13 cm / 5 1/8"



Aderer
47-672-11
11,5 cm / 4 4/8"



Aderer
47-674-13
13 cm / 5 1/8"

Universal-Kramponzange, Brückenabnehmezangen

Universal pliers, bridge removing pliers

Alicates universales, alicates para puentes

Pinces universelles, pinces d'extraction de bridge

Tenaglie universali, tenaglie per la rimozione di ponticelli

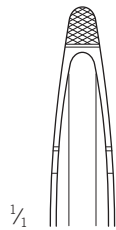

1/2

Waldsachs-Universal 47-690-15

15,5 cm / 5 1/8"

Universal-Kramponzange
Universal pliers
Alicates universales
Pinces universelles
Tenaglie universali

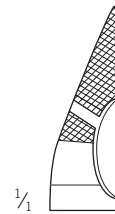

1/2

Universal 47-697-15

15,5 cm / 5 1/8"

Universal-Kramponzange
Universal pliers
Alicates universales
Pinces universelles
Tenaglie universali

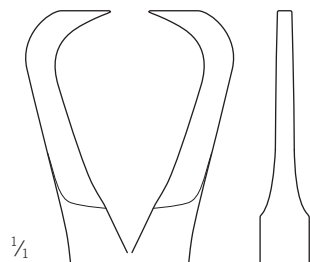

1/2

Furrer 47-702-15

15,5 cm / 5 1/8"

Brückenabnehmezangen
Bridge removing pliers
Alicates para puentes
Pinces d'extraction de bridge
Tenaglie per la rimozione di ponticelli

Kronenzangen, Konturzangen

Crown pliers, contouring pliers

Alicates para coronas y para contornear

Pinces à couronne, pinces des contours

Tenaglie per corone, tenaglie per profili

Technikzangen

Technic pliers

Alicates para técnica

Pinces pour technique

Tenaglie per tecnica

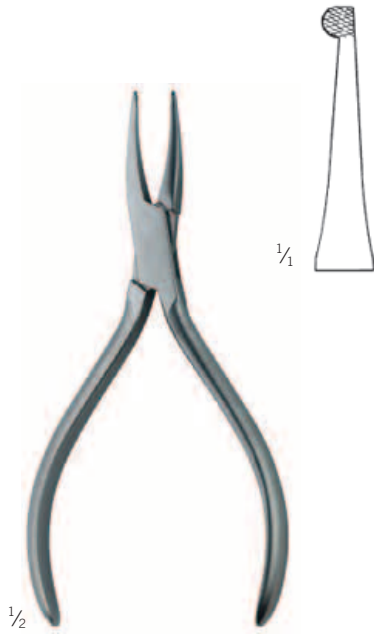
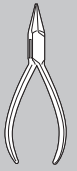

How
47-750-14
14 cm / 5 4/8"

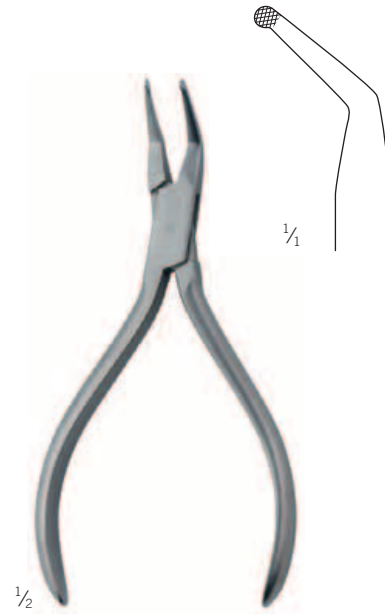

How
47-751-14
14 cm / 5 4/8"

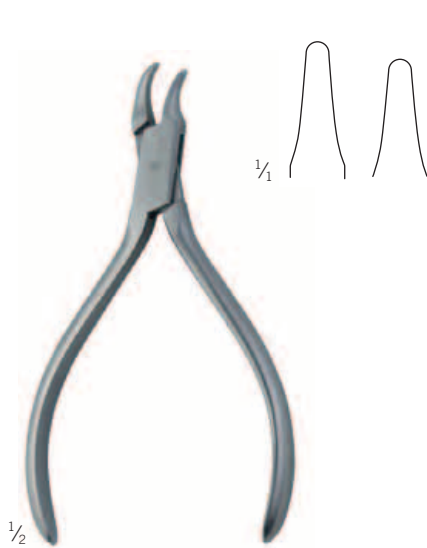

Reynolds
47-783-12
13 cm / 5 1/8"

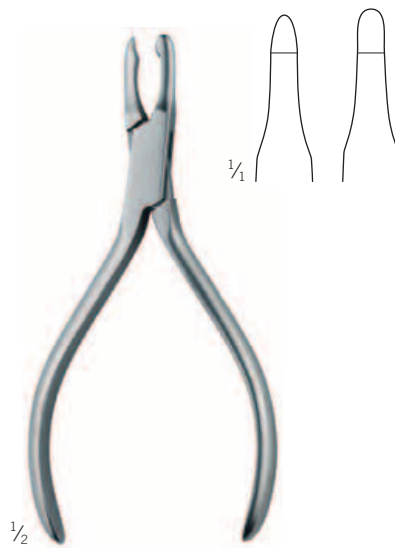

Johnson
47-788-13
13 cm / 5 1/8"

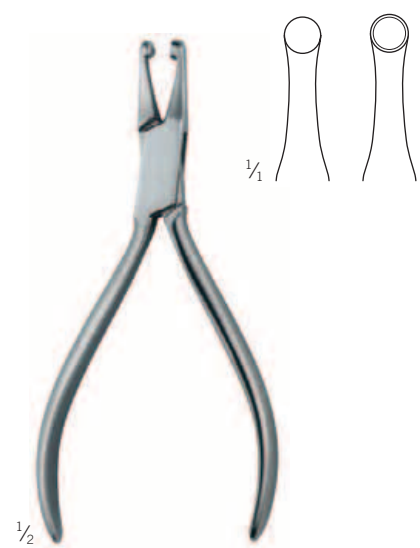

Abell
47-794-13
13 cm / 5 1/8"

Hämmer

Hammers/mallets

Martillos

Marteaux

Martelli



1/2

47-102-21

21 cm / 8 2/8"

Niethammer mit breiter Pinne
Riveting hammer wide edge
Martillo para remachar con peña ancha
Marteau à rivets avec large panne
Martello per ribadire a bordo largo



1/2

47-114-21

21 cm / 8 2/8"

Hornhammer
Horn mallet
Martillo córneo
Marteau à corne
Martello a corno



1/2

47-120-27

27 cm / 10 2/8"

Durofol-Hammer aus Kunststoff
Durofol plastic mallet
Martillo de Durofol de plástico
Marteau Durofol en plastique
Martello Durofol in plastica

54

Asepsis

Asepsis

Asepsia

Asepsie

Asepsi

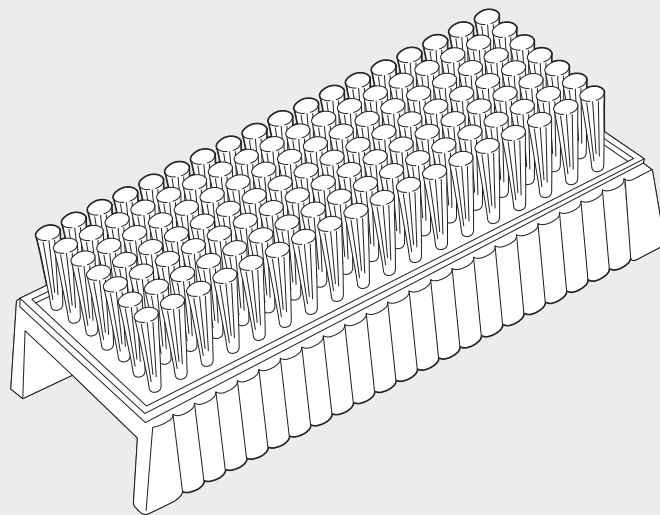

Nagelscheren, Nagelzangen, Hautscheren

Nail Scissors, Cuticle Scissors

Tijeras para uñas, Tijeras cuticulares

Ciseaux à ongles, Ciseaux à envies

Forbici per unghie, Forbici per pelle

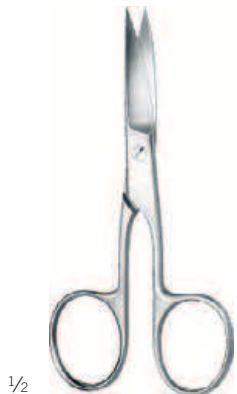

1/2

54-305-10
10,5 cm / 4 1/8"



1/2

54-336-14
14 cm / 5 4/8"
54-336-16
16 cm / 6 2/8"



1/2

54-347-13
13 cm / 5 1/8"



1/2

54-353-12
12 cm / 4 5/8"



1/2

54-378-10 - 54-378-12
feines Modell
delicate pattern
modelo delicado
modèle fin
modello fino
54-378-10 10,5 cm / 4 1/8"
54-378-12 11,5 cm / 4 4/8"



1/2

54-379-10 - 54-379-12
feines Modell
delicate pattern
modelo delicado
modèle fin
modello fino
54-379-10 10,5 cm / 4 1/8"
54-379-12 11,5 cm / 4 4/8"

Nagelfeilen, Infektions-Schutzbrillen, Gesichtsschutz

Nail Files, Protection Spectacles, Face Protection Mask

Limas para uñas, Gafas protectoras, Protector de cara

Limes à ongles, Lunettes protectrices, Protecteur facial

Lime per unghie, Occhiali protettivi, Protettore faciale

Asepsis

Asepsis

Asepsia

Asepsie

Asepsi

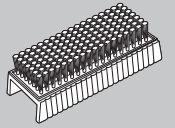

1/2

54-386-10
10 cm / 3 7/8"



1/2

54-388-11
11 cm / 4 3/8"



1/2

54-389-16
16 cm / 6 2/8"
Saphirbelag
sapphire coating
recubrimiento de zafiro
couche en saphir
rivestimento in zaffiro



Zeller
54-405-01

55

Hygiene, Aufbewahrung

Hygiene, Storage

Higiene, Almacenaje

Hygiène, Stockage

Igiene, Magazzinaggio

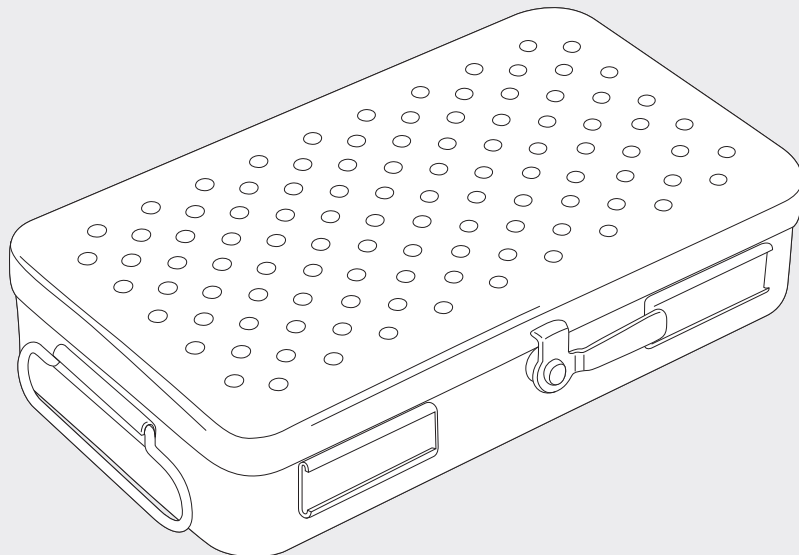

Sterilisierzangen, Nadeletuis

Sterilizing Forceps, Needle Cases

Pinzas para esterilización, Estuches para agujas

Pinces pour instruments stérilisés, Boîtes pour aiguilles

Pinze per strumenti sterilizzati, Scatole per aghi



1/3

Cheattle

55-085-27

27 cm / 10 5/8"

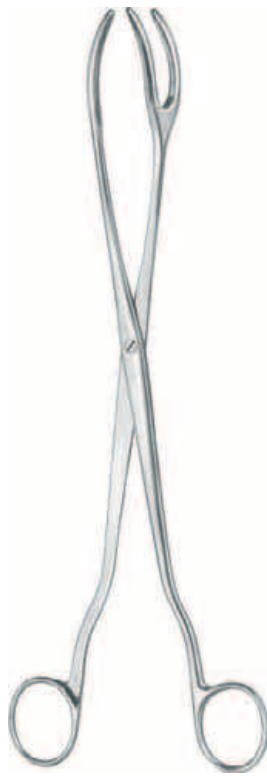

1/3

55-091-30

30 cm / 11 5/8"



ca. 1/3

Sauerbruch

55-162-20

210 x 125 x 17 mm

Deckel und Boden perforiert
perforated lid and bottom
tapa y fondo perforado
couvercle et fond perforé
coperchio e fondo perforati



ca. 1/3

Sauerbruch

55-164-20

210 x 125 x 17 mm

Deckel und Boden perforiert
perforated lid and bottom
tapa y fondo perforado
couvercle et fond perforé
coperchio e fondo perforati

Verbandstofftrommeln, Nadeletuis

Dressing Sterilizing Drums, Needle Cases

Tambores para esterilización, Estuches para agujas

Boîtes pour stérilisation de pansements, Boîtes pour aiguilles

Scatole per sterilizzare bendaggi, Scatole per aghi

Hygiene, Aufbewahrung

Hygiene, Storage

Higiene, Almacenaje

Hygiène, Stockage

Igiene, Magazzinaggio

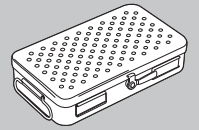

St
18/8

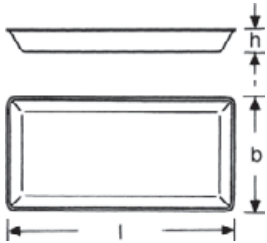

55-300-50 50 x 25 x 4,5 mm

55-300-65 65 x 42 x 8 mm

55-300-75 75 x 25 x 4,5 mm

55-302-50 50 x 25 x 4,5 mm

55-302-65 65 x 42 x 8 mm

55-302-75 75 x 25 x 4,5 mm



1/2

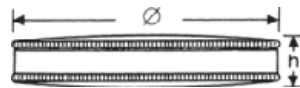

55-309-65

h = 18 mm Ø 67 mm

komplett mit perforierter Innendose
complete with perforated interior box
completa con caja interior perforada
complet avec boîte intérieure perforée
completo con scatola interiore perforata

55-310-65

h = 15 mm Ø 61 mm

Innendose, Deckel und Boden perforiert
Interior Box, perforated lid and bottom
Caja interior, tapa y fondo perforado
Boîte intérieure, couvercle et fond perforé
Scatola per aghi, coperchio e fondo perforati



1/2

Martin-Propel

55-313-08

h = 63 mm Ø 78 mm

mit Schlitz im Deckel, zur Aufnahme gebrauchter Bohrer
slotted lid, for disposal of used burrs
tapa con hendida, para sacar fresas usadas
avec fente dans le couvercle, pour la prise des mèches utilisées
con fessura nel coperchio, per buttare via punte usate



55-322-13

135 x 100 x 25 mm

Abdrucklöfeldose
Impression tray box
Cucharón para impresiones
Boîte porte empreintes
Cassetta di stampa

Nadeldosen, Nadelkassetten, Bereitstellungsbecher

Needle Cases, Needle Cases, Storing Cup

Estuches para agujas, Estuches para agujas, Tarro para instrumentos

Boîtes pour aiguilles, Boîtes pour aiguilles, Goblet pour instruments

Scatole per aghi, Scatole per aghi, Contenitore per strumenti

St
18/8



1/4

55-335-01
150 x 95 x 13 mm



1/4

55-335-02
150 x 95 x 13 mm

Deckel und Boden perforiert
perforated lid and bottom
tapa y fondo perforado
couvrclre et fond perforé
coperchio e fondo perforati



1/4

55-335-03
150 x 95 x 13 mm

Boden perforiert
perforated bottom
fondo perforado
fond perforé
fondo perforato



1/4

55-335-05
150 x 95 x 13 mm

Deckel und Boden perforiert
perforated lid and bottom
tapa y fondo perforado
couvrclre et fond perforé
coperchio e fondo perforati



1/4

55-337-01
150 x 95 x 13 mm



1/4

55-337-02
150 x 95 x 13 mm

Deckel und Boden perforiert
perforated lid and bottom
tapa y fondo perforado
couvrclre et fond perforé
coperchio e fondo perforati



1/4

55-340-02
150 x 95 x 11 mm

Nadelschale, Boden perforiert
Needle Tray, perforated bottom
Bandeja para agujas, fondo perforado
Boîte pour aiguilles, fond perforé
Scatola per aghi, fondo perforati



55-348-00
h = 75 mm Ø 75 mm

für Mikroinstrumente, mit auswechselbarer Silikon-Bodenplatte
for micro instruments, with exchangeable silicone plate
para micro instrumentos, con plaquita de silicona cambiabile
pour micro instruments, avec plaque de fond en silicone interchangeable
per micro strumenti, con stuovia di silicone intercambiabile



55-348-01
Silikoneinlage
Silicone plate
Plaquita de silicona
Plaque de silicone
Stuovia in silicone



55-348-00

Kappenzangen

Dressing Forceps in jar with cap

Pinza en tarro con tapa

Combinaison couvercle/pince

Pinza-coperchio

Hygiene, Aufbewahrung

Hygiene, Storage

Higiene, Almacenaje

Hygiène, Stockage

Igiene, Magazzinaggio

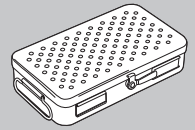

St
18/8



1/3

Mod. Martin

55-358-25

Standgefäß 20,5 cm hoch,
mit 25 cm langer Kornzange

jar 20,5 cm high,
with 25 cm long dressing forceps

tarro 20,5 cm de altura,
con pinza de vendaje de 25 cm

goblet 20,5 cm de hauteur,
avec pince à pansement de 25 cm longueur

contenitore 20,5 cm di altezza,
con pinza per medicatura di 25 cm di lunghezza



Mod. Martin

55-358-32

Standgefäß 25,5 cm hoch,
mit 32 cm langer Kornzange

jar 25,5 cm high,
with 32 cm long dressing forceps

tarro 25,5 cm de altura,
con pinza de vendaje de 32 cm

goblet 25,5 cm de hauteur,
avec pince à pansement de 25 cm longueur

contenitore 25,5 cm di altezza,
con pinza per medicatura di 32 cm di lunghezza

Lagerungstray

Storing Tray

Tray para depositar

Plateau pour déposer instruments

Bacinella per mettere strumenti

St
18/8

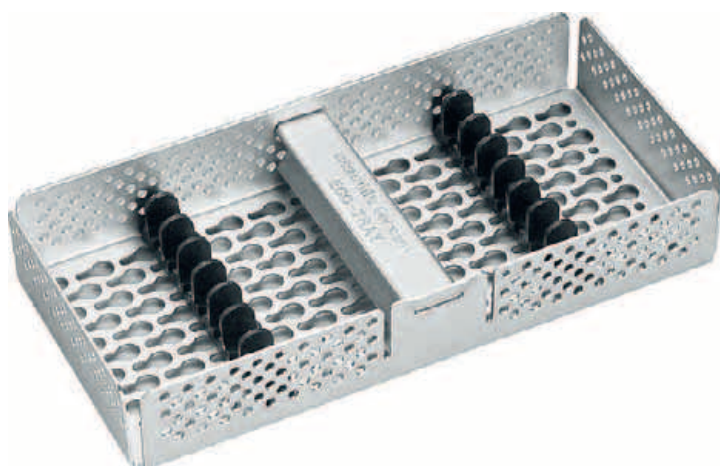

Martin-ECO

55-395-12

180 x 125 x 30 mm

für 11 feine Instrumente bis 17 cm,
mit 24 Stück Steckelementen Art.-Nr.
55-005-02, und 2 Lagerungsstegen

for 11 delicate instruments up to
17 cm, 24 each plug-in elements
ref. 55-005-02 and 2 each storage strips

para 11 instrumentos finos hasta
17 cm, 24 unid. elementos de enchufe
ref. 55-005-02 y 2 unid. puentes

pour instruments fins jusqu'à 17 cm,
24 éléments de fixation réf. 55-005-02
et 2 éléments de fixation

per strumenti di fino a 17 cm,
24 elementi di fissazione rif.
55-005-02 con 2 elementi di
fissazione

Martin-ECO

55-395-18

180 x 85 x 30 mm

für feine Instrumente bis 17 cm,
mit Fixierelement Art.-Nr. 55-395-26,
16 Stück Steckelementen Art.-Nr. 55-005-
02 und 2 Stegen Art.-Nr. 55-004-07

for delicate instruments up to 17 cm,
with fixation bar ref. 55-395-26, 16 each
plug-in elements ref. 55-005-02 and
2 each storage strips ref. 55-004-07

para instrumentos finos hasta 17 cm,
con cerrojo ref. 55-395-26, 16 unid. elementos
de enchufe ref. 55-005-02 y 2 unid. puentes
ref. 55-004-07

pour instruments fins jusqu'à 17 cm,
avec élément de fixation réf. 55-395-26,
16 éléments de fixation réf. 55-005-02
et 2 éléments de fixation réf. 55-004-07

per strumenti di fino a 17 cm, con elemento
di fissazione rif. 55-395-26, 16 elementi di
fissazione rif. 55-005-02 con 2 elementi di
fissazione 55-004-07

Martin-ECO

55-395-25

240 x 85 x 30 mm

für feine Instrumente bis 23 cm,
mit Fixierelement Art.-Nr. 55-395-26,
16 Stück Steckelementen Art.-Nr. 55-005-
02 und 2 Stegen Art.-Nr. 55-004-07

for delicate instruments up to 23 cm,
with fixation bar ref. 55-395-26, 16 each
plug-in elements ref. 55-005-02 and
2 each storage strips ref. 55-004-07

para instrumentos finos hasta 23 cm,
con cerrojo ref. 55-395-26, 16 unid. elementos
de enchufe ref. 55-005-02 y 2 unid. puentes
ref. 55-004-07

pour instruments fins jusqu'à 23 cm,
avec élément de fixation réf. 55-395-26,
16 éléments de fixation réf. 55-005-02
et 2 éléments de fixation réf. 55-004-07

per strumenti di fino a 23 cm, con elemento
di fissazione rif. 55-395-26, 16 elementi di
fissazione rif. 55-005-02 con 2 elementi di
fissazione 55-004-07

55-395-26

Fixierelement
Fixation Bar
Cerrojo
Élément de fixation
Elemento per fissazione

mit Silikoneinlage
with silicone insert
con capa de silicona
avec plaque de silicone
con inserto in silicone



55-395-18 &
55-395-25

Lagerungstray

Storing Tray

Tray para depositar

Plateau pour déposer instruments

Bacinella per mettere strumenti

Hygiene, Aufbewahrung

Hygiene, Storage

Higiene, Almacenaje

Hygiène, Stockage

Igiene, Magazzinaggio

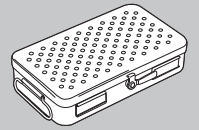

St
18/8



55-398-00

Wandmodell mit Aufhängung
zur Aufnahme von Martin-Deponetten
wall-mounted model with suspension
for storage of Martin-Deponettes
modelo de techo con suspensión
para depositar las cajas Martin-Deponette
modèle mural avec suspension
pour la prise de déponettes Martin
modello di parete con sospensione
per la presa di depositori Martin-Deponette



55-398-01

Tischmodell ohne Aufhängung
zur Aufnahme von Martin-Deponetten
table-top model without suspension
for storage of Martin-Deponettes
modelo de tablero sin suspensión
para depositar las cajas Martin-Deponette
modèle de table sans suspension
pour la prise de déponettes Martin
modello da tavola senza sospensione
per la presa di depositori Martin-Deponette

55-398-99

Schlitztuch
Slotted towel
Paño perforado
Champs avec fente
Telo sparato

70 x 70 cm

grün, Schlitz 15 cm
green, slot 15 cm
verde, hendidura 15 cm
vert, fente 15 cm
verde, fessura 15 cm

Bereitschaftskästen

Storing Cases

Cajas para almacenaje

Boîtes pour stockage

Scatole per magazzinaggio

St
18/8



55-400-23 - 55-400-42

Deckel und Boden perforiert, mit Scharnierdeckel perforated lid and bottom, with hinged lid tapa y fondo perforado, con tapa de bisagra couvricle et fond perforé, avec couvercle à charnières coperchio e fondo perforati, con copericho a cerniera	Ersatz-Textilfilter. Packung mit 5 Paar Spare Textile Filters, package of 5 pairs Filtros de tejido de recambio, paquete con 5 pares Filtres en tissu de rechange, paquet avec 5 paires Filtri di tessuti di ricambio, pacchetto con 5 paia
55-400-23 = 230 x 130 x 50 mm	55-409-23
55-400-26 = 260 x 150 x 50 mm	55-409-26
55-400-27 = 275 x 235 x 50 mm	55-409-28
55-400-30 = 300 x 200 x 50 mm	55-409-30
55-400-32 = 325 x 275 x 50 mm	55-409-32
55-400-42 = 420 x 175 x 50 mm	55-409-42
55-402-23 = 230 x 130 x 75 mm	55-409-23
55-402-26 = 260 x 150 x 75 mm	55-409-26
55-402-30 = 300 x 200 x 75 mm	55-409-30
55-402-32 = 325 x 275 x 75 mm	55-409-32
55-402-42 = 420 x 175 x 75 mm	55-409-42

Tücher, Reinigungs- und Pflegemittel

Towels, cleaning and care agents

Paños, detergentes y productos de curación

Linges, agents de nettoyage et d'entretien

Panni, detergenti e prodotti di cura

Hygiene, Aufbewahrung

Hygiene, Storage

Higiene, Almacenaje

Hygiène, Stockage

Igiene, Magazzinaggio

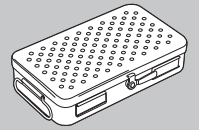

Abdecktücher / Einschlagtücher
Covering towels/wrappers
Paños para cubrir y envolver
Linges d'opération/linges enveloppants
Tessuti di copertura/tessuti di avvolgimento

55-996-54

70 x 70 cm

OP-grün

OR-green

Verde quirófano

Vert OP

Verde, per sala operatoria

55-669-58

60 x 60 cm

Grün, für Trays

Green, for trays

Verde, para bandejas

Vert, pour plateaux

Verde, per bacinelle

55-999-80

Edelstahlreiniger

Stainless steel cleaner

Limpiador para acero inoxidable

Nettoyant pour acier inox

Detergente per acciaio inossidabile

500 ml

55-999-89

Eloxalreiniger für Alubehälter

Cleaner for anodized aluminum containers

Limpiador para contenedores de aluminio anodizado

Nettoyant pour conteneurs en aluminium anodisé

Detergente per contenitori in alluminio anodizzato

300 ml

MicroStop® – Mini-Set

Kleine Container, große Sicherheit

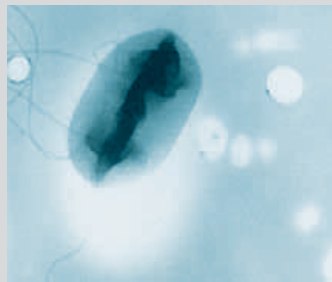

Jetzt kommen die Kleinen ganz groß raus: Die Mini-Set-Sterilcontainer wurden in konsequenter Anlehnung an die „großen“ Container mit der Sterilbarriere MicroStop® entwickelt. Klein und handlich, dafür genauso sicher, genauso wirtschaftlich – und genauso überlegen. So wird KLS Martin einmal mehr dem hohen Anspruch einer modernen ZSVA gerecht: durchgängige Sicherheit und Wirtschaftlichkeit von A bis Z – mit MicroStop®.

Sterilization



55

GB

MicroStop® – Mini-Set
Small containers, high safety level

Small containers are great: the Mini-Set Sterile Containers have been developed directly in line with „large“ containers using the MicroStop® sterile barrier. Small and easy to handle, yet just as safe and economical – and just as superior, enabling KLS Martin to satisfy once more the demands of present day Central Sterile Supplies: consistent safety and economy throughout provided by MicroStop®.

ES

Mini-sets – MicroStop®
Contenedores pequeños, gran seguridad

Unos elementos pequeños que ahora se revelan como bien grandes: los contenedores estériles en formato mini-set han sido diseñados consecuentemente a imitación de los “grandes” contenedores con la barrera estéril MicroStop®. Son pequeños y manejables, pero igual de seguros y económicos... ¡Sencillamente, superiores! Así pues, KLS Martin satisface una vez más las altas exigencias de los modernos departamentos centrales de esterilización de útiles: seguridad en toda la regla y rentabilidad desde el principio hasta el final gracias a MicroStop®.

F

MicroStop® – set miniature
Petits conteneurs offrant une grande sécurité

Désormais, les « petits » impressionnent énormément : les conteneurs de stérilisation du set miniature ont été développés, sur la base des « grands » conteneurs, avec la barrière de stérilisation MicroStop®. Ils sont petits et maniables, mais tout aussi fiables, tout aussi rentables – et tout aussi performants. Ainsi la société KLS Martin répond une fois de plus aux exigences élevées de la stérilisation centrale moderne : sécurité et rentabilité constantes de A à Z – grâce à MicroStop®.

I

MicroStop® – Mini-Set
Piccoli contenitori, grande sicurezza

I piccoli contenitori ora diventano grandi: i mini-set sterili sono stati progettati rifacendosi ai “grandi” contenitori dotati di barriera sterile Microstop®. Piccoli e maneggevoli, ugualmente sicuri ed economici – e di qualità altrettanto elevata. Ancora una volta la KLS Martin soddisfa gli elevati requisiti delle moderne Centrali di Sterilizzazione: con Microstop® sicurezza e convenienza sotto ogni punto di vista, dalla A alla Z!

MicroStop® - Mini-Set-Container

MicroStop® - mini-set containers

Contenedores MicroStop® Mini-Set

Conteneurs stériles Mini-Set MicroStop®

Contenitori Mini-Set MicroStop®

MicroStop® - Mini-Set-Container MicroStop® - mini-set containers Contenedores MicroStop® Mini-Set Conteneurs stériles Mini-Set MicroStop® Contenitori Mini-Set MicroStop®

Außenmaße (L x B x H) External dimensions (L x W x H) Dimensiones exteriores (L x An x A) Dimensions extérieures (L x l x h) Dimensioni esterne (L x P x A)	Innenmaße (L x B x H) Internal dimensions (L x W x H) Dimensiones interiores (L x An x A) Dimensions intérieures (L x l x h) Dimensioni interne (L x P x A)
---	---

55-861-40 310 x 189 x 65 mm 283 x 177 x 40 mm

55-861-60 310 x 189 x 80 mm 283 x 177 x 60 mm

Protokollkärtchen Log labels Etiquetas de registro Etiquettes de traçabilité Etichette di protocollo

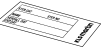
	mit Indikator	für Container, VE* = 1000 Stück
	with indicator	for container, 1 SU* = 1,000 pcs/pack
	con indicador	para contenedor, UE* = 1000 unidades
	avec indicateur	pour conteneur, UC* = 1000 unités
	con indicatore	per contenitore, UI* = 1000 pezzi

Codierschilder (für Inhalts- und Zielangabe) Coding labels (for content and destination details) Etiquetas de codificación (para detalles de contenido y destino) Etiquettes de codage (pour les indications de contenu et de destination) Targhette di codifica (per l'indicazione del contenuto e della destinazione)

	Deckel / Lid / Tapa / Couvercle / Coperchio		
	<table border="1"> <thead> <tr> <th>Loch Hole Perforadas Perforation Foro</th> <th>Beschriftung Inscription Rotulada Inscription Con dicitura</th> </tr> </thead> </table>	Loch Hole Perforadas Perforation Foro	Beschriftung Inscription Rotulada Inscription Con dicitura
Loch Hole Perforadas Perforation Foro	Beschriftung Inscription Rotulada Inscription Con dicitura		
55-864-01	– •		
55-864-02	– –		
55-864-03	• •		
55-864-04	• –		

	Front / Front / Frontal / Frontal / Frontale		
	<table border="1"> <thead> <tr> <th>Loch Hole Perforadas Perforation Foro</th> <th>Beschriftung Inscription Rotulada Inscription Con dicitura</th> </tr> </thead> </table>	Loch Hole Perforadas Perforation Foro	Beschriftung Inscription Rotulada Inscription Con dicitura
Loch Hole Perforadas Perforation Foro	Beschriftung Inscription Rotulada Inscription Con dicitura		
55-864-05	– •		
55-864-06	– –		

Logistik-Rähmchen (in Verbindung mit Codierschildern für Deckel) Logistics framelets (for use with lid coding labels) Marquitos logísticos (en relación con etiquetas de codificación para la tapa) Cadres de logistique (en liaison avec des étiquettes de codage pour le couvercle) Cornicina logistica (in collegamento alle targhette di codifica per il coperchio)



	Farbe	Color	Color	Couleur	Colore
55-864-10	schwarz	black	negro	noir	nero
55-864-11	weiß	white	blanco	blanc	bianco
55-864-12	rot	red	rojo	rouge	rosso
55-864-13	blau	blue	azul	bleu	blu
55-864-14	grün	green	verde	vert	verde
55-864-15	gelb	yellow	amarillo	jaune	giallo
55-864-16	lila	mauve	lila	mauve	lilla
55-864-17	orange	orange	naranja	orange	arancione
55-864-18	grau	gray	gris	gris	grigio

Drahtsiebschalen Wire-mesh trays Bandejas cribadas de malla de alambre Paniers grillagés Griglie a filo metallico



	Außenmaße (L x B x H) External dimensions (L x W x H) Dimensiones exteriores (L x An x A) Dimensions extérieures (L x l x h) Dimensioni esterne (L x P x A)
55-808-20	260 x 170 x 28 mm
55-808-21	260 x 170 x 47 mm

Siebtray Perforated trays Bandejas perforadas Plateaux Bacinelle



	Außenmaße (L x B x H) External dimensions (L x W x H) Dimensiones exteriores (L x An x A) Dimensions extérieures (L x l x h) Dimensioni esterne (L x P x A)
55-015-10	277 x 171 x 30 mm
55-015-20	277 x 171 x 38 mm
55-015-30	277 x 171 x 54 mm

Noppenmatten Silicone mats Esteras de silicona Tapis en silicone Tappetini in silicone

55-009-00	für Container for container para contenedor pour conteneur per contenitore
	264 x 174 mm

55-009-01	für Siebschalen / Trays for trays / perforated or wire-mesh bandejas cribadas / bandejas pour paniers / plateaux Per griglie / bacinelle
	252 x 161 mm

MicroStop® - Mini-Set-Container

MicroStop® - mini-set containers

Contenedores MicroStop® Mini-Set

Conteneurs stériles Mini-Set MicroStop®

Contentitori Mini-Set MicroStop®

Hygiene, Aufbewahrung

Hygiene, Storage

Higiene, Almacenaje

Hygiène, Stockage

Igiene, Magazzinaggio

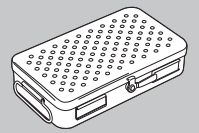

Basisinstrumentenstege Bottom strips for instrument fixation Regletas básicas para instrumentos Bandes de support pour la fixation des instruments Listelli di base per il fissaggio degli strumenti

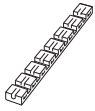

Maße
Dimensions
Dimensiones
Dimensions
Dimensioni

55-004-02	längs/longitud./largo/longues/lungo	237 mm
55-004-03	quer/transverse/oblicuo/transversale/trasversale	162 mm
55-004-04	kurz/short/corto/courtes/corto	75 mm
55-004-07	Lagerungssteg allein, ohne Steckelemente Storage bridge, without plug-in elements Puenje de storage, sin elementos de plug-in Sentier de stockage, sans éléments à l'est Ponticello di magazzinaggio, senza elementi al sono	

Steckelemente Plug-in elements Elementos enchufable Éléments enfichables Elementi di fissaggio

55-005-01	mit Auflage with support con asiento avec support con base	VE* = 16 Stück SU* = 16 pcs/pack UE* = 16 unidades UC* = 16 unités UI* = 16 pezzi
55-005-02	ohne Auflage without support sin asiento sans support senza base	VE* = 16 Stück SU* = 16 pcs/pack UE* = 16 unidades UC* = 16 unités UI* = 16 pezzi

Federelemente Spring elements Elementos de resorte Éléments à ressort Elementi a molla



für Trayhöhe 30 mm
for tray height of 30 mm
para altura de bandeja 30 mm
pour hauteur de plateau de 30 mm
per una bacinella alta 30 mm

55-006-01	längs/longitud./largo/longues/lungo	237 mm
55-006-02	quer/transverse/oblicuo/transversale/trasversale	162 mm
55-006-03	kurz/short/corto/courtes/corto	75 mm

für Trayhöhe 38 u. 54 mm
for tray heights of 38 and 54 mm
para alturas de bandeja 38 y 54 mm
pour hauteurs de plateau de 38 et 54 mm
Per bacinelle alte 38 e 54 mm

55-006-04	längs/longitud./largo/longues/lungo	237 mm
55-004-05	quer/transverse/oblicuo/transversale/trasversale	162 mm
55-004-06	kurz/short/corto/courtes/corto	75 mm

Kleinteilekorb Basket for small parts Canesta para partes pequeñas Corbeille pour parties petites Cesto per parti piccole

55-891-40	80 x 80 x 40 mm
-----------	-----------------

Anschlagrahmen für Trays Stop frames (tray dividers) Marco de tope para bandejas Cadre de butée pour plateaux Divisori per le bacinelle

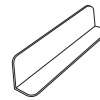

für Trayhöhe 30 u. 38 mm
for tray heights of 30 and 38 mm
para alturas de bandeja 30 y 38 mm
pour hauteurs de plateau de 30 et 38 mm
Per bacinelle alte 30 e 38 mm

55-008-01	quer/transverse/oblicuo/transvers./trasversale	162 x 20 mm
55-008-02	kurz/short/corto/courtes/corto	75 x 20 mm

für Trayhöhe 54 mm
for tray height of 54 mm
para altura de bandeja 54 mm
pour hauteur de plateau de 54 mm
per una bacinella alta 54 mm

55-008-03	quer/transverse/oblicuo/transvers./trasversale	162 x 40 mm
55-008-04	kurz/short/corto/courtes/corto	75 x 40 mm

Spannrahmen Spring frame Bastidor de fijación Cadre tendeur Telaio

55-009-06	für Container for container para contenedor pour conteneur per il contenitore
-----------	---



Fixierelemente Fixing elements Elementos de fijación Éléments de fixation Elementi di fissaggio

55-007-01	für Trayhöhe 30 mm for tray height of 30 mm para altura de bandeja 30 mm p. hauteur de plateau de 30 mm p. una bacinella alta 30 mm	für Ringgriffinstr. for ring handle instruments p. instrumentos de mango angular p. instruments à manche annulaire per strumenti con presa ad anello
-----------	---	--



55-007-02	für Trayhöhe 38 u. 54 mm for tray heights of 38 and 54 mm para alturas de bandeja 38 y 54 mm p. haut. de plateau de 38 et 54 mm Per bacinelle alte 38 e 54 mm	für Ringgriffinstr. for ring handle instruments p. instrumentos de mango angular p. instruments à manche annulaire per strumenti con presa ad anello
-----------	---	--

Aufnahmebox Storage box Caja de recepción Boîte de rangement Scatola di raccolta

55-008-10	für Bohrer und Elektroden for drill bits and electrodes para brocas y electrodos pour forets et électrodes per punte da trapano ed elettrodi
-----------	--

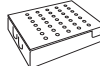

56

Gefäße aus Edelstahl

Stainless Steel Receptacles
Recipientes de acero inoxidable
Récipients en acier inoxydable
Recipienti di acciaio inossidabile

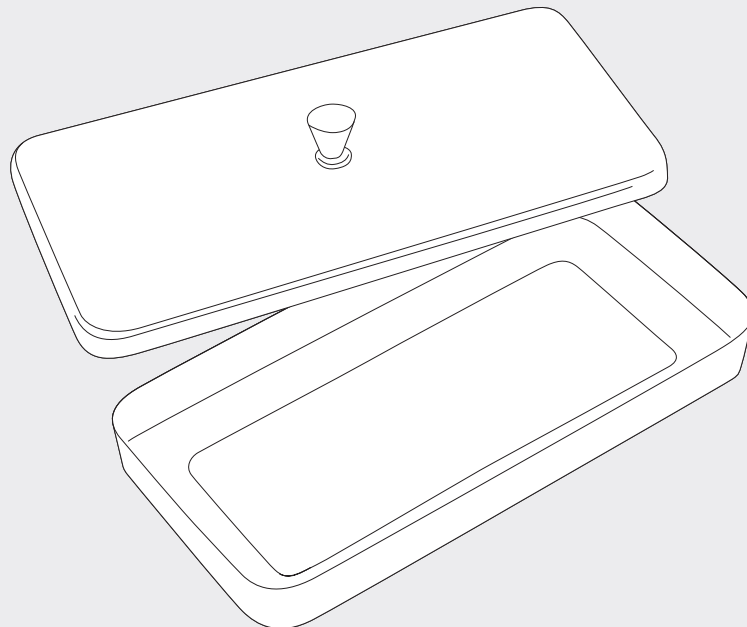

Metallschalen, Messbecher, Petrischalen

Stainless Steel Bowls, Measurers, Petri Dishes

Cubetas de acero inoxidable, Vaso-medidas, Cápsulas de Petri

Cuvettes de acier inoxydable, Mesures graduées, Boîtes de Petri

Scodelle di acciaio inossidabile, Bicchieri graduati. Scodella di Petri

St
18/8



Ø x h

56-231-04	Ø 40 x 19 mm	20 ccm
56-231-06	Ø 61 x 30 mm	70 ccm
56-231-08	Ø 80 x 40 mm	140 ccm
56-231-11	Ø 116 x 50 mm	250 ccm
56-231-12	Ø 128 x 55 mm	350 ccm
56-231-14	Ø 147 x 65 mm	500 ccm
56-231-16	Ø 167 x 75 mm	900 ccm
56-231-18	Ø 187 x 85 mm	1.300 ccm

Ø x h

56-235-11	Ø 116 x 35 mm	200 ccm
56-235-12	Ø 128 x 38 mm	300 ccm
56-235-14	Ø 147 x 50 mm	400 ccm
56-235-16	Ø 167 x 45 mm	500 ccm
56-235-18	Ø 187 x 45 mm	800 ccm

Ø x h

56-240-11	Ø 110 x 28 mm	150 ccm
-----------	---------------	---------



innen graduiert
graduated inside
graduado interiormente
gradué intérieurement
graduato all'interno

56-254-01 = 100 ccm



innen graduiert
graduated inside
graduado interiormente
gradué intérieurement
graduato all'interno

56-256-02 = 250 ccm

56-256-05 = 500 ccm

56-256-10 = 1.000 ccm

56-256-20 = 2.000 ccm



mit Deckel
with lid
con tapa
avec couvercle
con coperchio

Ø x h

56-280-10 = Ø 100 x 20 mm



ohne Deckel
without lid
sin tapa
sans couvercle
senza coperchio

Ø x h

56-284-09 = Ø 96 x 20 mm



Petrischalendeckel
Lid for Petri Dishes
Tapa para cápsulas de Petri
Couvercle pour boîtes de Petri
Scodella rotonda



56-280-10

56-285-10

Mehrzweckschalen, Instrumententabletts

Universal Trays, Instrument Trays

Bandejas universales, Bandejas para instrumentos

Plateaux universaux, Plateaux pour instruments

Bacinelle universali, Bacinelle per strumenti

Gefäße aus Edelstahl

Stainless Steel Receptacles

Recipientes de acero inoxidable

Récipients en acier inoxydable

Recipienti di acciaio inossidabile

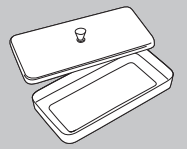

St
18/8

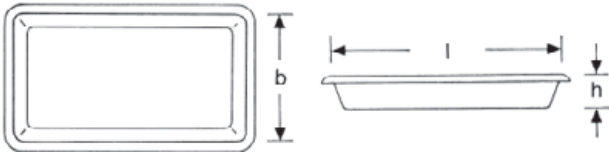

l x b x h

56-321-23 = 230 x 155 x 30 mm

56-321-30 = 300 x 175 x 30 mm

56-321-31 = 300 x 175 x 40 mm

56-321-35 = 350 x 240 x 40 mm

56-321-40 = 470 x 320 x 50 mm



l x b x h

56-324-21 = 210 x 160 x 10 mm

56-324-24 = 240 x 180 x 10 mm

56-324-30 = 310 x 150 x 10 mm

56-324-31 = 310 x 210 x 10 mm

56-324-35 = 350 x 240 x 10 mm

56-324-40 = 420 x 290 x 20 mm

56-324-42 = 400 x 300 x 12 mm

56



l x b x h

56-340-23 = 235 x 190 x 40 mm



Ø x h

56-348-22 = Ø 220 mm x 70 mm

Standgefäße, Instrumentenkästen

Metal Jars, Instrument Boxes

Tarros metálicos, Cajas para instrumentos

Récipients en métal, Boîtes pour instruments

Recipienti metallici, Scatole per strumenti

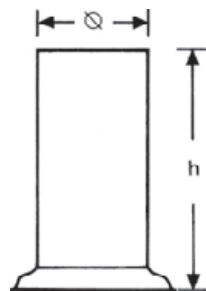

Deckel allein, geschlossen
Lid only, closed
Tapa suelta, cerrada
Couvercle seul, fermé
Coperchio solo, chiuso



Deckel allein, mit dreieckiger Aussparung
Lid only, with triangular opening
Tapa suelta, con abertura triangular
Couvercle seul, avec ouverture triangulaire
Coperchio solo, con apertura triangolare

56-360-30 = Ø 30 mm x 90 mm

-

-

56-360-50 = Ø 50 mm x 100 mm

56-365-50 = Ø 50 mm

56-366-50 = Ø 50 mm

56-360-51 = Ø 50 mm x 130 mm

56-365-50 = Ø 50 mm

56-366-50 = Ø 50 mm

56-360-52 = Ø 50 mm x 175 mm

56-365-50 = Ø 50 mm

56-366-50 = Ø 50 mm

56-360-75 = Ø 75 mm x 100 mm

56-365-75 = Ø 75 mm

56-366-75 = Ø 75 mm

56-360-76 = Ø 75 mm x 130 mm

56-365-75 = Ø 75 mm

56-366-75 = Ø 75 mm

56-360-77 = Ø 75 mm x 175 mm

56-365-75 = Ø 75 mm

56-366-75 = Ø 75 mm

56-360-98 = Ø 100 mm x 175 mm

56-365-99 = Ø 100 mm

56-366-99 = Ø 100 mm

56-360-99 = Ø 100 mm x 200 mm

56-365-99 = Ø 100 mm

56-366-99 = Ø 100 mm



mit Knopfdeckel
lid with knob
tapa con botón
avec couvercle à bouton
con coperchio a bottone

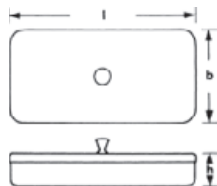

Deckel ohne Knopf
lid without knob
tapa sin botón
couvercle sans bouton
coperchio senza bottone

l x b x h

56-411-16 = 165 x 85 x 35 mm

56-411-20 = 200 x 100 x 35 mm

56-411-21 = 200 x 100 x 50 mm

56-411-23 = 230 x 130 x 50 mm

56-411-26 = 260 x 150 x 50 mm

56-411-27 = 270 x 235 x 50 mm

56-411-30 = 300 x 200 x 50 mm

56-411-33 = 325 x 275 x 50 mm

l x b x h

56-412-16 = 165 x 85 x 35 mm

56-412-20 = 200 x 100 x 35 mm

56-412-21 = 200 x 100 x 50 mm

56-412-23 = 230 x 130 x 50 mm

56-412-26 = 260 x 150 x 50 mm

56-412-27 = 270 x 235 x 50 mm

56-412-30 = 300 x 200 x 50 mm

56-412-32 = 325 x 275 x 30 mm

56-412-33 = 325 x 275 x 50 mm

56-412-42 = 420 x 80 x 40 mm

56-412-43 = 420 x 175 x 50 mm

Instrumentenkästen, Metall Dosen, Medizinbecher

Instrument Boxes, Round Metal Boxes, Medicine Cups

Cajas para instrumentos, Cajas metálicas redondas, Vasos medicinales

Boîtes pour instruments, Boîtes pour instruments, Gobelets

Scatole per strumenti, Scatole per strumenti, Bicchieri per medicina

Gefäße aus Edelstahl

Stainless Steel Receptacles

Recipientes de acero inoxidable

Réipients en acier inoxydable

Recipienti di acciaio inossidabile

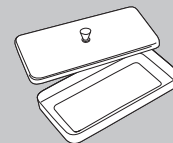

St
18/8



l x b x h

56-419-20 = 205 x 105 x 40 mm



Ø x h

56-430-06 = Ø 75 mm x 60 mm

56-430-07 = Ø 75 mm x 75 mm

56-431-06 = Ø 100 mm x 60 mm

56-431-10 = Ø 100 mm x 100 mm

56-432-08 = Ø 125 mm x 80 mm

56-432-12 = Ø 125 mm x 125 mm

56-435-15 = Ø 150 mm x 150 mm

56



56-602-25

25 ccm

innen graduiert
graduated inside
graduado interiormente
gradué intérieurement
graduato all'interno



56-604-50

50 ccm

innen graduiert
graduated inside
graduado interiormente
gradué intérieurement
graduato all'interno



56-610-20

Medizinlöffel

Medicine Spoon
Cuchara medicinal
Cuiller pour médicaments
Cucchiaio per medicina
20 ccm

innen graduiert
graduated inside
graduado interiormente
gradué intérieurement
graduato all'interno
Cucchiaio per medicina



56-620-75

Tablettenschale

Tablet Tray
Bandejita para tabletas
Plateau pour comprimés
Bacinella per compresse
Ø 75 x 12 mm

Becher, Nierenschale

Cups, Kidney Dishes

Tarros, Riñoneras

Récipients, Bassins réniformes

Recipienti, Bacinelle reniformi

St
18/8



56-650-90

Mundbecher
Metal Cup
Vaso metálico
Goblet en métal
Bicchiere metallico
Ø 90 x 90 mm



56-654-75

Zahnprothesenbecher
Denture Cup
Tarro para prótesis dental
Récipient à prothèses dentaires
Recipiente per protesi dentarie
Ø 75 x 50 mm
mit Deckel
with lid
con tapa
avec couvercle
con coperchio



56-662-75

Sputumbecher
Sputum Cup
Escupidera
Crachoir
Sputacchiera
Ø 75 mm x 80 mm



56-669-75

Bechereinsatz
Insert for Cup
Enjerto para escupidera
Insert pour crachoir
Inserto per sputacchiera
Ø 73 x 75 mm



Nierenschalen-Deckel
Lid for Kidney Dishes
Tapa para riñoneras
Couvercle pour bassins réniformes
Coperchio per bacinelle reniformi

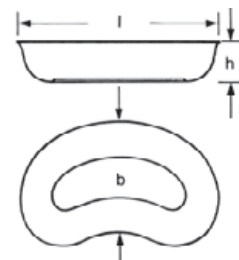

l x b x h

56-673-17 = 170 x 100 x 35 mm

56-673-25 = 250 x 140 x 40 mm

56-673-27 = 275 x 150 x 45 mm

56-675-25

—

Wattspender, Wattebehälter, Watteabfallbehälter

Cotton Dispensers, Waste Cotton Collector

Dispensadores de algodón, Recipiente para desperdicios

Distributeurs de coton, Porte-déchets

Distributori di cotone, Portarifiuti

Gefäße aus Edelstahl

Stainless Steel Receptacles

Recipientes de acero inoxidable

Récipients en acier inoxydable

Recipienti di acciaio inossidabile

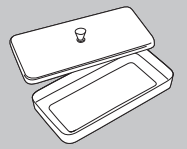

St
18/8



56-702-23 = Ø 230 mm

56-702-31 = Ø 300 mm

Cr



56-830-10

Puderstreuose

Powder Pot

Polvera

Distributeur de poudre

Distributore di polvere

Ø 50 x 100 mm

Cr



Methot
56-860-01

Ø 50 x 75 mm

mit Deckel

with lid

con tapa

avec couvercle

con coperchio



Methot
56-860-02

Ø 50 x 75 mm

ohne Deckel

without lid

sin tapa

sans couvercle

senza coperchio

Cr



Methot
56-868-01

Ø 50 x 75 mm



Methot
56-868-05

Einsatz

Insert

Injerto

Insert

Inserto

Ø 45 x 55 mm

Kunststoff
platic
plastico
matière en plastique
materiale plastico

56

Spritzenbänke

Syringe Racks

Dispositivo para jeringas

Support pour seringues

Supporto per siringhe



56-960-09

für 9 verschieden große Spritzen
for 9 syringes of different sizes
para 9 jeringas de diferentes tamaños
pour 9 seringues de différentes grandeurs
per 9 siringhe di diverse grandezze

Kunststoff
plastic
plástico
matière en plastique
materiale plastico

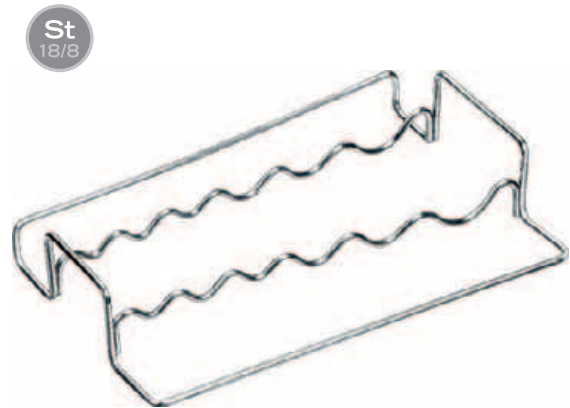

56-964-06

für 6 verschieden große Spritzen
for 6 syringes of different sizes
para 6 jeringas de diferentes tamaños
pour 6 seringues de différentes grandeurs
per 6 siringhe di diverse grandezze

57-71

Verschiedenes

Miscellaneous
Diversos artículos
Articles divers
Articoli diversi

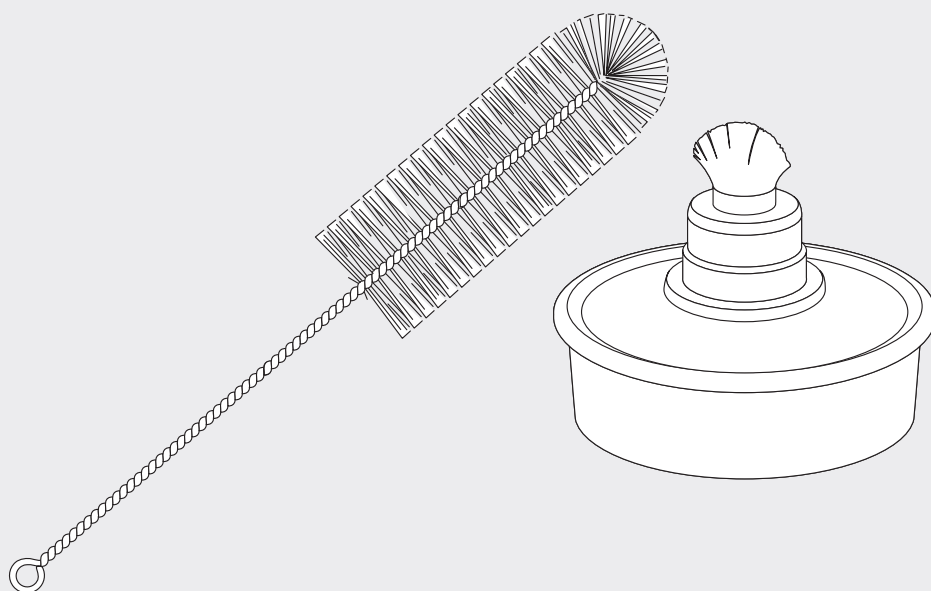

Norm-Trays

Standard trays
Bandejas estándar
Trays standard
Bacinelle standard



Martin Erg-O-Norm

288 x 187 x 40 mm

Norm-Tray-Kassette
Standard tray box
Estuche para bandejas estándar
Cassette tray standard
Bacinella standard

57-101-01 Boden gelocht, Deckel ungelocht
bottom perforated, lid unperforated
con base perforada y tapa no perforada
base perforée, couvercle non perforé
base perforata, coperchio non perforato

57-101-02 Boden ungelocht, Deckel gelocht
bottom unperforated, lid perforated
con base no perforada, tapa perforada
base non perforée, couvercle perforé
base non perforata, coperchio perforato

57-101-03 Boden und Deckel gelocht
bottom and lid perforated
con base y tapa perforadas
base et couvercle perforés
base e coperchio perforati

57-101-04 Boden und Deckel ungelocht
bottom and lid unperforated
con base y tapa no perforadas
base et couvercle non perforés
base e coperchio non perforati



Martin Erg-O-Norm

280 x 180 mm

57-101-10 Filterblech
Filter plate
Chapa filtrante
Tôle filtrante
Lamiera filtrante
mit 6 Haltern und Textilfilter
with 6 clips and cloth filter
con 6 grapas y tela filtrante
avec 6 agrafes et filtre textile
con 6 graffe e filtro tessile

57-101-11 Textilfilter
Cloth filter
Tela filtrante
Filtre textile
Filtro tessile
Satz zu 10 Stück
set of 10 pieces
juego de 10 piezas
kit de 10 unités
set da 10 pezzi

57-101-15 Papierfilter
Paper filter
Papel filtrante
Filtre de papier
Filtro di carta
Satz zu 100 Stück
set of 100 pieces
juego de 100 piezas
kit de 100 unités
set da 100 pezzi

Norm-Trays

Standard trays
Bandejas estándar
Trays standard
Bacinelle standard

Verschiedenes

Miscellaneous
Diversos artículos
Articles divers
Articoli diversi

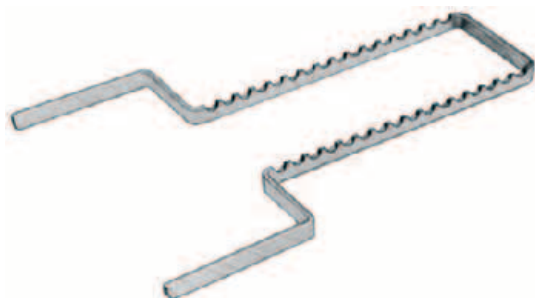

Martin Erg-O-Norm
57-101-21

Rasterbügel
Rack with slots
Arco de entallas
Etrier à grille
Staffa a griglia



Martin Erg-O-Norm
57-101-22

Rastersteg mit V-Einschnitten
längs und quer verwendbar

Rack with V-slots
can be used in longitudinal and transverse direction

Soporte con entallas en forma de V
para empleo longitudinal y transversal

Support à grille avec entailles en V
pour utilisation dans le sens longitudinal et transversal

Supporto a griglia con intaglia a V
per utilizzo in senso longitudinale e trasversale



Martin Erg-O-Norm
57-101-23

Rastersteg mit U-Einschnitten
längs und quer verwendbar

Rack with U-slots
can be used in longitudinal and transverse direction

Soporte con entallas en forma de U
para empleo longitudinal y transversal

Support à grille avec entailles en U
pour utilisation dans le sens longitudinal et transversal

Supporto a griglia con intaglia a U
per utilizzo in senso longitudinale e trasversale

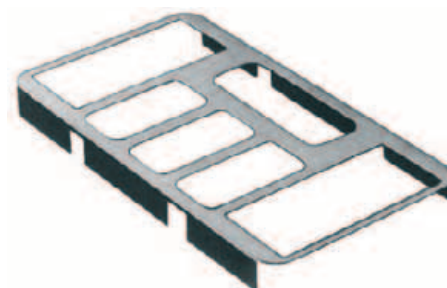

Martin Erg-O-Norm
57-101-30

180 x 100 mm

Einsatz für Norm-Tray
Rack for standard tray
Soporte para bandeja estándar
Insert pour tray standard
Inserto per bacinella standard

57-
71

Half-Trays

Half trays
Medias bandejas
Semi-trays
Semi-bacinelle



Martin Erg-O-Norm

288 x 93 x 40 mm

Half-Tray-Kassette

Half tray box

Estuche para medias bandejas

Cassette semi-tray

Cassetta semi-bacinella

57-110-01

Boden gelocht, Deckel ungelocht
bottom perforated, lid unperforated
con base perforada y tapa no perforada
base perforée, couvercle non perforé
base perforata, coperchio non perforato

57-110-02

Boden ungelocht, Deckel gelocht
bottom unperforated, lid perforated
con base no perforada, tapa perforada
base non perforée, couvercle perforé
base non perforata, coperchio perforato

57-110-03

Boden und Deckel gelocht
bottom and lid perforated
con base y tapa perforadas
base et couvercle perforés
base e coperchio perforati

57-110-04

Boden und Deckel ungelocht
bottom and lid unperforated
con base y tapa no perforadas
base et couvercle non perforés
base e coperchio non perforati



Martin Erg-O-Norm

280 x 180 mm

57-110-10

Filterblech
Filter plate
Chapa filtrante
Tôle filtrante
Lamiera filtrante

mit 6 Haltern und Textilfilter
with 6 clips and cloth filter
con 6 grapas y tela filtrante
avec 6 agrafes et filtre textile
con 6 graffe e filtro tessile

57-110-11

Textilfilter
Cloth filter
Tela filtrante
Filtre textile
Filtro tessile

Satz zu 10 Stück
set of 10 pieces
juego de 10 piezas
kit de 10 unités
set da 10 pezzi

57-110-15

Papierfilter
Paper filter
Papel filtrante
Filtre de papier
Filtro di carta

Satz zu 100 Stück
set of 100 pieces
juego de 100 piezas
kit de 100 unités
set da 100 pezzi

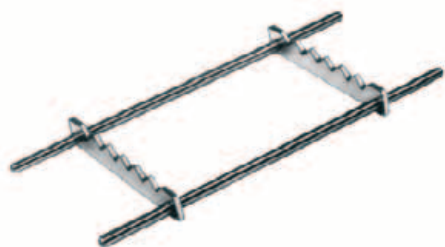

Martin Erg-O-Norm

57-110-22

Rastersteg mit V-Einschnitten

Rack with V-slots

Soporte con entallas en forma de V

Support à grille avec entailles en V

Supporto a griglia con intagli a V



Martin Erg-O-Norm

57-110-23

Rastersteg mit U-Einschnitten

Rack with U-slots

Soporte con entallas en forma de U

Support à grille avec entailles en U

Supporto a griglia con intagli a U

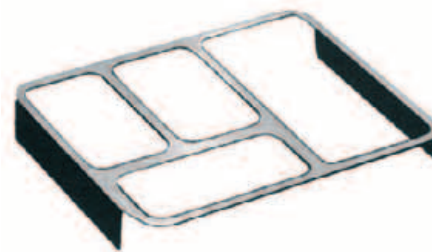

Martin Erg-O-Norm

57-110-30

88 x 100 mm

Einsatz für Half-Tray

Rack for half tray

Soporte para medias bandejas

Insert pour semi-tray

Inserto per semi-bacinella

Zubehör für Norm- und Half-Trays

Accessories for standard and half trays

Accesorios para bandejas estándar y medias bandejas

Accessoires pour trays standard et semi-trays

Accessori per bacinelle standard e semi-bacinelle

Verschiedenes

Miscellaneous

Diversos artículos

Articles divers

Articoli diversi

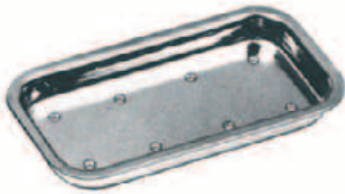

Martin Erg-O-Norm
57-120-05

55 x 29 mm

Schale, gelocht
Tray, perforated
Bandeja, perforada
Cuvette, perforée
Bacinella, perforata



Martin Erg-O-Norm
57-120-07

75 x 29 mm

Schale, gelocht
Tray, perforated
Bandeja, perforada
Cuvette, perforée
Bacinella, perforata



Martin Erg-O-Norm
57-120-09

90 x 37 mm

Schale, gelocht
Tray, perforated
Bandeja, perforada
Cuvette, perforée
Bacinella, perforata



Martin Erg-O-Norm
57-120-13

55 x 29 mm

Schale, gelocht, mit drei Fächern
Tray, perforated, with 3 partitions
Bandeja, perforada, con 3 divisiones
Cuvette, perforée, avec trois compartiments
Bacinella, perforata, con 3 comparti



Martin Erg-O-Norm
57-120-15

55 x 29 mm

Muldenschale, ungelocht
Trough-shaped tray, unperforated
Bandeja en forma de cubeta, no perforada
Auge, non perforée
Trogolo, non perforato



Martin Erg-O-Norm
57-125-05

48 x 22 mm

Pelleteinlage
Pellet holder
Soporte para bolitas
Inserto pour pellet
Inserto per pellet
für 12 Pellets
for 12 pellets
para 12 bolitas
pour 12 pellets
per 12 pellet

57-
71

Zubehör für Norm- und Half-Trays

Accessories for standard and half trays

Accesorios para bandejas estándar y medias bandejas

Accessoires pour trays standard et semi-trays

Accessori per bacinelle standard e semi-bacinelle



Martin Erg-O-Norm
57-130-05

48 x 22 mm

Bohrerblock

Burr holder

Soporte para taladros

Bloc à foret

Blocco trapano

für 2 FG- und 6 Winkelstückbohrer

for 2 FG and 6 offset burrs

para 2 taladros FG y 6 taladros acodados

pour 2 FG und 6 forets angulaires

per 2 trapani a filettatura fine e 6 trapani per pezzi a gomito

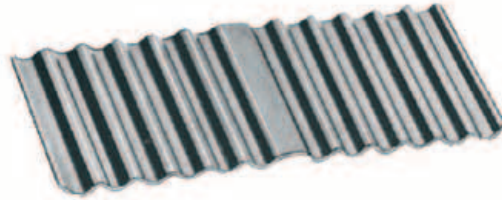

Martin Erg-O-Norm
57-130-07

77 x 32 mm

Bohrerblock

Burr holder

Soporte para taladros

Bloc à foret

Blocco trapano

für 6 FG-, Winkelstück- und 5 Handstückbohrer

for 6 FG, 6 offset and 5 handpiece burrs

para 6 taladros FG, 6 taladros acodados y 5 taladros portátiles

pour 6 FG, forets angulaires et 5 forets à main

per 6 trapani a filettatura fine, trapano per pezzi a gomito e per 5 trapani per pezzi manuali



Martin Erg-O-Norm
57-150-07

77 x 32 mm

Rilleneinlage

Groove tray

Soporte con ranuras

Insert cannelé

Inserto scanalato



Martin Erg-O-Norm

57-160-01

Aufsteck-Farbschild für Chirurgie

Colour plate, red for surgery

Placa en color rojo para operaciones

Plaque en couleurs pour la chirurgie

Insegna a colori per interventi chirurgici



57-160-02

Aufsteck-Farbschild für Extraktion

Colour plate, yellow for extraction

Placa en color amarillo para extracciones

Plaque en couleurs pour l'extraction

Insegna a colori per estrazioni



57-160-03

Aufsteck-Farbschild für Amalgamfüllungen

Colour plate, blue for amalgam fillings

Placa en color azul para obturaciones de amalgama

Plaque en couleurs pour les remplissages d'amalgame

Insegna a colori per otturazioni ad amalgama



57-160-04

Aufsteck-Farbschild für Kunststofffüllungen

Colour plate, green for plastic fillings

Placa en color verde para obturaciones de silicato

Plaque en couleurs pour les remplissages de plastique

Insegna a colori per otturazioni plastiche



Metallschalen

Stainless steel bowls
Cubetas de acero inoxidable
Cuvettes de acier inoxydable
Scodelle di acciaio inossidabile

Verschiedenes

Miscellaneous
Diversos artículos
Articles divers
Articoli diversi

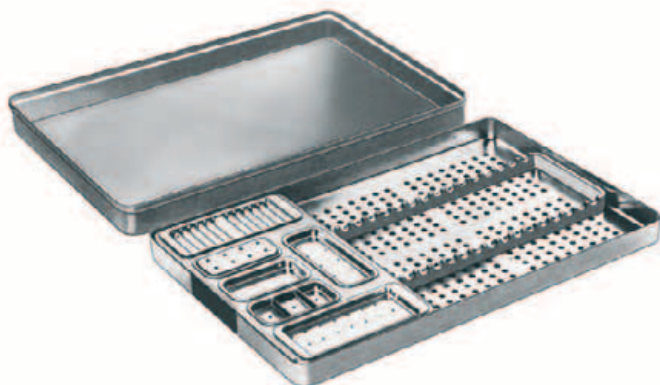
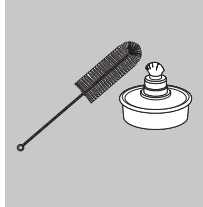

Martin Erg-O-Norm 57-201-01

288 x 187 x 40 mm

Norm-Tray für OP, komplett bestückt
Standard tray for operation, complete
Bandeja estándar para operaciones, completa
Tray standard pour intervention chirurgicale avec équipement complet
Bacinella standard per interventi operatori, con dotazione completa

Martin Erg-O-Norm 57-201-02

288 x 187 x 40 mm

Norm-Tray für Extraktion komplett bestückt
Standard tray for extraction, complete
Bandeja estándar para extracciones, completa
Tray standard pour extraction, avec équipement complet
Bacinella standard per estrazioni, con dotazione completa
ohne Abbildung
not illustrated
no ilustrado
sans illustration
senza illustrazione

57-
71

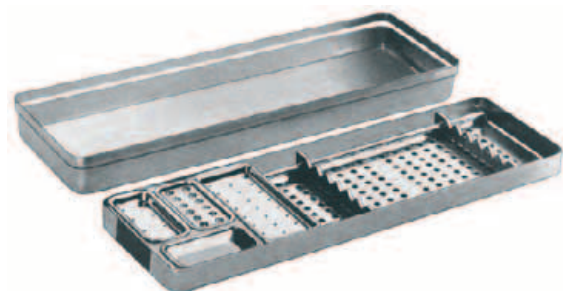

Martin Erg-O-Norm 57-210-01

288 x 93 x 40 mm

Half-Tray für Füllungen
Half tray for fillings
Media bandeja para empastes
Semi-tray pour remplissages
Semi-bacinella per otturazioni

Wipphahn-Brenner

Double lever stopcock burner

Mecheros con llave de palanca doble

Beccs pour la laboratoire

Becco del gas per laboratorio



15 cm / 6"

Ø 11 mm

mit Luftregulierung und Sparflamme, vernickelt
mit Gasdruck bis 500 mm Wassersäule

with air regulation and pilot flame, nickel-plated
for gas pressure up to 500 mm water gauge

con regulación de aire y llama económica, niquelado
para una presión de gas hasta 500 mm de columna de agua

avec régulation d'air et veilleuse, nickelé
avec pression de gaz jusqu'à 500 mm colonne d'eau

con regolazione dell'aria e fiamma economica, nichelato
per pressione del gas fino a colonne d'acqua di 500 mm

61-011-32

F - für Propan- oder Butangas
F - for propane or butane gas
F - para gas propano o butano
F - pour gaz propane ou butane
F - per gas propano o butano

61-011-42

N - für Erdgas
N - for natural gas
N - para gas natural
N - pour gaz naturel
N - per gas naturale



11 cm / 4 1/2"

Ø 11 mm

mit seitlichem Sparflammenrohr, Wipphahn umschaltbar
entweder brennen Haupt- und Sparflamme gemeinsam oder nur die Sparflamme

with lateral pilot flame tube, lever switchable
either main flame plus pilot flame burning or pilot flame only

con llama económica lateral, llave de palanca doble
conmutable a llama principal o económica o sólo la llama económica

avec tube de veilleuse latéral, levier commutable
soit la flamme principale ou la veilleuse brûlent ensemble ou uniquement la veilleuse

con tubo laterale per fiamma economica, leva commutabile
su fiamma principale ed economica o soltanto fiamma economica

61-015-32

F - für Propan- oder Butangas
F - for propane or butane gas
F - para gas propano o butano
F - pour gaz propane ou butane
F - per gas propano o butano

61-015-42

N - für Erdgas
N - for natural gas
N - para gas natural
N - pour gaz naturel
N - per gas naturale

Wipphahn-Brenner

Double lever stopcock burner
Mecheros con llave de palanca doble
Beccs pour la laboratoire
Becco del gas per laboratorio

Verschiedenes

Miscellaneous
Diversos artículos
Articles divers
Articoli diversi

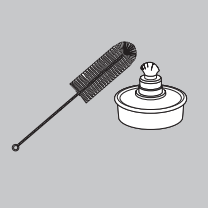

14 cm / 5 1/2"

Ø 11 mm

mit seitlichem Sparflammenrohr, Wipphahn umschaltbar
entweder brennen Haupt- und Sparflamme gemeinsam oder nur die Sparflamme

with lateral pilot-flame tube, lever switchable
either main flame plus pilot flame burning or pilot flame only

con llama económica lateral, llave de palanca doble
conmutable a llama principal o económica o sólo la llama económica

avec tube de veilleuse latéral, levier commutable
soit la flamme principale ou la veilleuse brûlent ensemble ou uniquement la veilleuse

con tubo fiamma economica laterale, leva commutabile
su fiamma principale ed economica o soltanto fiamma economica

61-023-32

F - für Propan- oder Butangas
F - for propane or butane
F - para gas propano o butano
F - pour gaz propane ou butane
F - per gas propano o butano

61-023-42

N - für Erdgas
N - for natural gas
N - para gas natural
N - pour gaz naturel
N - per gas naturale



Micro-Standard

61-132-37

8,5 cm / 3 1/4"

Ø 6 mm

mit Stabilisierungskamin, Gasregulierung durch Kegventil, auf kleinste
Flamme regulierbar, für Gasdruck bis 500 mm Wassersäule, verchromt

with stabilizing chimney, gas regulation with conical valve, flame
adjustable, for gas pressure up to 500 mm water gauge, chromium-plated

con chimenea de estabilización, la válvula cónica regula la salida del gas,
llama ajustable, para presión de gas hasta 500 mm de columna de agua, cromado

cheminée de stabilisation, régulation du gaz par vanne à boisseau,
à flamme réglable, pour pression de gaz jusqu'à 500 mm colonne d'eau, chromé

con camino di stabilizzazione, regolazione del gas mediante rubinetto
conico regolabile sulla fiamma minima, per pressioni di gas fino a colonna d'acqua di
500 mm, cromato

61-132-37

F - für Propan- oder Butangas
F - for propane or butane gas
F - para gas propano o butano
F - pour gaz propane ou butane
F - per gas propano o butano

61-132-42

N - für Erdgas
N - for natural gas
N - para gas natural
N - pour gaz naturel
N - per gas naturale

Reinigungsbürsten

Cleaning brushes

Cepillos de limpieza

Brosses à lavement

Spazzole per pulire

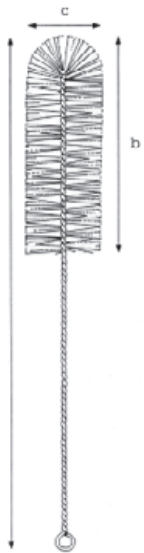

a x b x c



73-301-03
250 x 70 x 3 mm



73-303-03
425 x 70 x 3 mm



73-304-07
285 x 75 x 7 mm



73-306-08
270 x 65 x 8 mm



73-306-12
270 x 65 x 12 mm



73-306-13
230 x 60 x 13 mm



73-306-15
205 x 60 x 15 mm



73-308-20
215 x 65 x 20 mm



73-308-25
215 x 65 x 25 mm



73-308-30
215 x 65 x 30 mm

Reinigungsbürsten

Cleaning brushes
Cepillos de limpieza
Brosses à lavement
Spazzole per pulire

Verschiedenes

Miscellaneous
Diversos artículos
Articles divers
Articoli diversi



73-315-00

Satz mit 5 Bürsten
set of 5 brushes
juego de 5 cepillos
jeu de 5 brosses
set a 5 spazzole

73-315-13 = 215 x 60 x 13 mm

73-315-15 = 215 x 65 x 15 mm

73-315-13 – 73-315-28



73-318-30

300 x 120 x 30 mm

73-318-50

320 x 130 x 50 mm

73-370-95

210 x 95 mm

57-
71

Abfalleimer

Waste bucket

Cobo para desechos

Seau pour déchets

Secchia per rifiuti



73-454-15

Ø = 325 mm, h= 305 mm

Inhalt
Capacity
Capacidad
Capacité
Capacità

15 l



73-455-15

Deckel
Lid
Tapa
Couvercle
Coperchio



73-454-15



1/5

Martin
73-470-58

58 cm / 22 5/8"



1/5

Sauerbruch
73-474-55

55 cm / 21 5/8"

80

HF-Chirurgie

HF Surgery
Cirugia AF
Chirurgie HF
Chirurgia AF

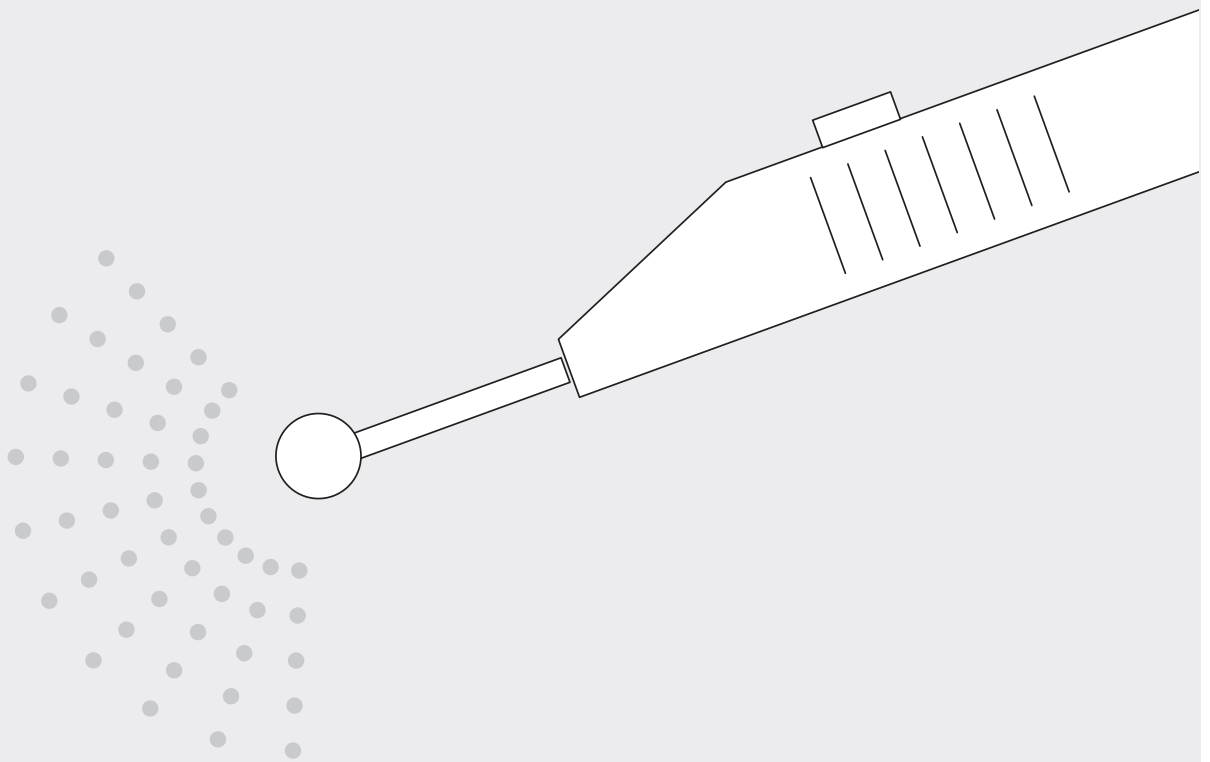

Elektrochirurgie-Gerät MD 62

Electrosurgical unit MD 62

Aparato electroquirúrgico MD 62

Appareil électrochirurgical MD 62

Apparecchio elettrochirurgico MD 62



KLS Martin MD 62

Die Anwendung der HF-Chirurgie gilt im Dentalbereich als gesicherte und bewährte Methode. Das Elektrochirurgie-Gerät KLS Martin MD 62 erfüllt durch seine Ausstattung und Ausgangsleistung alle Anforderungen im Dentalbereich.

Umfangreiches Zubehör hoher Qualität

Der speziell den anatomischen Verhältnissen im Mund angepasste Handgriff und ein umfangreiches Programm von Aktivelektroden sind die Basis für eine zuverlässige Anwendung in der täglichen Praxis.

Ausgewählte Zubehörteile haben wir zu einem Satz zusammengefasst.

KLS Martin MD 62

HF surgery is considered a safe and proven method in dentistry. With its special features and accessories and matching output power, KLS Martin's MD 62 electrocautery unit meets all requirements in this field.

Wide Range of High-Quality Accessories

Handles specially optimized for use in the oral cavity plus a comprehensive range of active electrodes guarantee the unit's usefulness and reliability in daily practice.

Selected accessories have been combined into a practical set.

KLS Martin MD 62

El empleo de la cirugía de alta frecuencia se considera un método seguro y acreditado en el campo odontológico. El aparato de electrocirugía KLS Martin MD 62 cumple todos los requisitos de este campo gracias a su equipamiento y a su potencia de salida.

Extensa gama de accesorios de alta calidad

El mango diseñado especialmente para las condiciones anatómicas en la boca y una amplia gama de electrodos activos constituyen la base para una aplicación fiable y segura en la práctica diaria.

Los accesorios más importantes que se han seleccionado están agrupados en un juego.

Anwendungsbeispiele aus dem Bereich der Zahnheilkunde:

- Gingivoplastik/Gingivektomie
- Dentitio difficilis
- Blutstillung mit HF-Strom (Elektrokoagulation)
- Biopsie
- Resektion/Koagulation von Tumoren
- Sterilisation von Wurzelkanälen
- Chirurgie der Mundschleimhaut (Abszesse, Wucherungen, Fibrome)
- Verlängerung zu kurzer Zahnkronen oder zu kurzer Pfeilerzähne für Brücken
- Operation eines abnormen Lippen- oder Zungenbändchens
- Desensibilisierung freiliegender Zahnhälse

Application examples from dentistry:

- Gingivoplasty/gingivectomy
- Dentitio difficilis
- Hemostasis by using HF current (electrocoagulation)
- Biopsy
- Tumor resection/coagulation
- Root canal sterilization
- Mucosal surgery (removal of abscesses, overgrowth, fibromas)
- Lengthening of tooth crowns or abutment teeth that are too short for bridge support
- Surgical treatment of abnormal labial or lingual frenula
- Desensitization of bare dental necks

Ejemplos de aplicación en el campo de la odontología:

- Gingivoplastia/gingivectomía
- Dentición difícil
- Hemostasis con corriente de alta frecuencia (electrocoagulación)
- Biopsia
- Resección/coagulación de tumores
- Esterilización de conductos radiculares
- Cirugía de la mucosa bucal (abscesos, vegetaciones, fibromas)
- Prolongación de coronas dentarias demasiado cortas o dientes de apoyo demasiado cortos para puentes
- Operación de un frenillo de labio o frenillo de lengua anormal
- Desensibilización de bordes gingivales que han quedado al descubierto

Elektrochirurgie-Gerät MD 62

Electrosurgical unit MD 62
Aparato electroquirúrgico MD 62
Appareil électrochirurgical MD 62
Apparecchio elettrochirurgico MD 62

HF-Chirurgie

HF Surgery
Cirugía AF
Chirurgie HF
Chirurgia AF

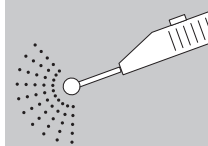

MD 62 de KLS Martin

L'utilisation de l'électrochirurgie dans le domaine dentaire est considérée comme une méthode sûre et éprouvée. Le bistouri électrique MD 62 de KLS Martin répond, avec ses équipements spécifiques, à toutes les exigences dans le domaine de la chirurgie dentaire.

Large choix d'accessoires de grande qualité

Le manche spécialement adapté à l'anatomie buccale ainsi qu'une gamme complète d'électrodes actives garantissent une utilisation fiable au quotidien.

Des accessoires sélectionnés ont été réunis pour former un lot qui permet un vaste éventail d'applications possibles.

KLS Martin MD 62

L'applicazione dell'elettrochirurgia ad alta frequenza nel settore dentale è considerata un metodo sicuro e sperimentato. L'apparecchio elettrochirurgico KLS Martin MD 62 soddisfa con la sua dotazione tecnica e la sua potenza di uscita tutte le esigenze del settore dentale.

Ampia gamma di accessori ad alta qualità

L'impugnatura, particolarmente adatta alle condizioni anatomiche del cavo orale, ed un ampio programma di elettrodi attivi costituiscono la base per un impiego affidabile nell'uso quotidiano.

Gli accessori più importanti sono stati selezionati e raggruppati in un set.

Exemples d'applications en odontologie:

- Gingivoplastie/gingivectomie
- Dentitio difficilis
- Hémostase avec du courant HF (électrocoagulation)
- Biopsie
- Résection/coagulation de tumeurs
- Stérilisation de canaux de racine
- Chirurgie de la muqueuse buccale (abcès, proliférations de tissus, fibromes)
- Prolongement de couronnes trop courtes ou de dents piliers trop courtes pour supporter des bridges
- Opération d'une anomalie au niveau du frein des lèvres ou de la langue
- Désensibilisation de collets de dents à nu

Esempi di applicazione nel settore dell'odontologia:

- Plastica gengivale/gingivectomia
- Dentitio difficilis
- Emostasi con corrente ad alta frequenza (elettrocoagulazione)
- Biopsia
- Resezione/coagulazione di tumori
- Sterilizzazione dei canali radicolari
- Chirurgia della mucosa orale (ascessi, proliferazioni, fibromi)
- Prolungamento di corone dentarie troppo corte o di pilastri per ponti troppo corti
- Operazione di un frenulo labiale o linguale anormale
- Desensibilizzazione di colletti dentali scoperti

Zubehörsätze für MD 62

Accessory sets for MD 62
 Juegos de accesorios para MD 62
 Jeux d'accessoires pour MD 62
 Serie di accessori per MD 62



80-006-02

Elektrochirurgie-Gerät MD 62
 Electro-surgical unit MD 62
 Aparato electroquirúrgico MD 62
 Appareil électrochirurgical MD 62
 Apparecchio elettrochirurgico MD 62

Technische Daten MD 62		Technical specifications MD 62		Datos técnicos MD 62	
Netzanschluss	110 - 120 V, 50 / 60 Hz 220 - 240 V, 50 / 60 Hz	Mains voltage/ power supply	110-120 V, 50-60 Hz 220-240 V, 50-60 Hz	Toma de red	110 - 120 V, 50/60 Hz 220 - 240 V, 50/60 Hz
Schutzklasse	I	Class of protection	I	Clase de seguridad	I
Medizinprodukt der Klasse	II b/MPG gem. 93/42/EWG	Medical device class	II b MDD (acc. to Directive 93/42/EEC)	Producto sanitario según clase	II b/MDD según Directiva 93/42/CEE
Typ	BF	Type of equipment	BF	Tipo	BF
Nennfrequenz	1000 kHz	Rated frequency	1000 kHz	Frecuencia nominal	1.000 kHz
Impulsfrequenz	500 kHz	Pulse frequency	500 kHz	Frecuencia de impulsos	500 kHz
Leckströme NF und HF	gemäß IEC 601 Teil 2-2	LF/HF leakage currents	as per IEC 601, Part 2-2	Corriente de fugas en baja y alta frecuencia	según IEC 601 parte 2-2
HF-Ausgangsleistung		HF output power:		Potencia de salida de AF	
Stromart SCHNEIDEN	50 Watt an 600 Ohm	CUTTING current	50 W at 600 ohms	Tipo de corriente CORTE	50 Watios a 600 Ohmios
Stromart KOAGULATION	30 Watt an 1200 Ohm	COAGULATION current	30 W at 1200 ohms	Tipo de corriente COAGULACIÓN	30 Watios a 1.200 Ohmios
Gewicht	2,8 kg	Weight	2,8 kg	Peso	2,8 kg
Abmessungen	78 mm hoch 200 mm breit 185 mm tief	Dimensions	78 mm (H) 200 mm (W) 185 mm (D)	Dimensiones	78 mm de altura 200 mm de anchura 185 mm de profundidad
CE-Kennzeichnung	konform mit 93/42/EWG	CE marking	conform with 93/42/EEC	Marcación CE	conforme con 93/42/CEE

80-107-00	Satz Zubehör MD 62 Hand, bestehend aus:	Accessory set for MD 62 for hand switch operation, consisting of:	Juego de accesorios MD 62 con interruptor digital, compuesto de:
80-214-11	1 Handgriff mit Fingerschalter, 3 m Kabel	- Electrode handle with finger switch and connection cable of 3 m	- Mango porta-electrodos con interruptor y cable de conexión de 3 m
80-444-08	1 Elektroden-Ständer für 8 Dentalelektroden	- Electrode box for 8 dental electrodes	- Caja para 8 electrodos dentales
80-461-01	1 Nadelelektrode	- Needle electrode	- Electrodo de aguja
80-461-02	1 Nadelelektrode	- Needle electrode	- Electrodo de aguja
80-461-12	1 Schlingenelektrode	- Loop electrode	- Electrodo de asa de alambre
80-461-14	1 Schlingenelektrode	- Loop electrode	- Electrodo de asa de alambre
80-461-15	1 Schlingenelektrode	- Loop electrode	- Electrodo de asa de alambre
80-461-31	1 Koagulations-Nadelelektrode	- Coagulation needle electrode	- Electrodo de aguja, para la coagulación
80-461-34	1 Koagulations-Kugelelektrode	- Coagulation ball electrode	- Electrodo de bola, para la coagulación

Zubehörsätze für MD 62

Accessory sets for MD 62
Juegos de accesorios para MD 62
Jeux d'accessoires pour MD 62
Serie di accessori per MD 62

HF-Chirurgie

HF Surgery
Cirugía AF
Chirurgie HF
Chirurgia AF

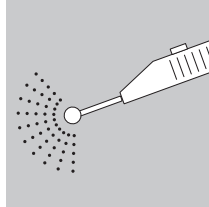

Caractéristiques techniques du MD 62

Dati tecnici MD 62

Tension d'alimentation	110-120 V, 50 / 60 Hz 220-240 V, 50 / 60 Hz	Alimentazione di rete	110 - 120 V, 50 / 60 Hz 220 - 240 V, 50 / 60 Hz
Classe de protection	I	Grado di protezione	I
Dispositif médical du type	II b (conformément à la directive 93/42/CEE)	Dispositivo medicale di classe	II b/ MDD sec. norme 93/42/CEE
Type	BF	Tipo	BF
Fréquence nominale	1000 kHz	Frequenza nominale	1000 kHz
Fréquence d'impulsions	500 kHz	Frequenza degli impulsi	500 kHz
Courants de fuite BF et HF	conformément à IEC 601, partie 2-2	Correnti di dispersione a bassa ed alta tensione	secondo IEC 601 parte 2-2
Puissance de sortie HF		Potenza di uscita di alta frequenza	
Courant de SECTION	50 watts pour 600 ohms	Tipo di corrente di TAGLIO	50 watt a 600 Ohm
Courant de COAGULATION	30 watts pour 1200 ohms	Tipo di corrente de COAGULAZIONE	30 watt a 1200 Ohm
Poids	2,8 kg	Peso	2,8 kg
Dimensions	78 mm de haut 200 mm de large 185 mm de profondeur	Dimensioni	78 mm di altezza 200 mm di larghezza 185 mm di profondità
Marquage CE	conforme à 93/42/CEE	Marchatura CE	secondo le norme 93/42/CEE

80

80-107-00 Lot d'accessoires MD 62 pour commande digitale, composé de:

Serie di accessori standard MD 62, per attivazione a mano, composta di:

80-214-11	1	Manche porte-électrodes avec interrupteur et câble de raccordement de 3 m	- Manico portaelettrodi con interruttore e cavo di connessione di 3 m
80-444-08	1	Boîte pour 8 électrodes dentaires	- Supporto per 8 elettrodi dentali in scatola
80-461-01	1	Electrode aiguille	- Elettrodo ad ago
80-461-02	1	Electrode aiguille	- Elettrodo ad ago
80-461-12	1	Electrode anse	- Elettrodo ad ansa
80-461-14	1	Electrode anse	- Elettrodo ad ansa
80-461-15	1	Electrode anse	- Elettrodo ad ansa
80-461-31	1	Electrode aiguille pour la coagulation	- Elettrodo ad ago per coagulazione
80-461-34	1	Electrode boule pour la coagulation	- Elettrodo a sfera per coagulazione

Zubehör für MD 62

Accessories for MD 62

Accesorios para MD 62

Accessoires pour MD 62

Accessori per MD 62

Ø 1,6 mm

1/2



Ø 12,5 mm

80-214-11 – KLS Martin

Dental-Elektroden-Handgriff mit einer Taste, mit großem Koax-Stecker und 3 m Anschlusskabel

Dental electrode handle with a pushbutton, with large coax plug and connection cable of 3 m

Mango porta-electrodos dental con una tecla, con clavija coaxial grande y cable de conexión de 3 m

Manche porte-électrodes dentaire avec un interrupteur digital, avec grande fiche coax et câble de raccordement de 3 m

Manico portaelettrodi dentale con un tasto, con spina coassiale grande e cavo di connessione da 3 m



80-444-08

für 8 Elektroden mit Schaft

Ø 1,6 mm

for 8 electrodes with shaft

Ø 1,6 mm

para 8 electrodos con vástago de

Ø de 1,6 mm

pour 8 électrodes à tige de

Ø 1,6 mm

per 8 elettrodi con asta di

Ø 1,6 mm



80-812-10

Einpedal-Fußschalter, Air, 2 m Luftschlauch

Foot switch, Air, 2-m tube

Interruptor de pie, Air, 2 m tubo

Interrupteur à pédale, Air, 2 m chambre à air

Interruttore a pedale, Air, 2 m camera d'aria



mit 6,3-mm-Stecker
with 6.3-mm plug
con clavija de 6,3 mm
avec fiche de 6,3 mm
con spina da 6,3 mm

Handzylinder nur bis max. 50 W zugelassen!

Hand cylinder approved only for max. 50 W!

¡La utilización del cilindro de mano sólo está permitida hasta un máximo de 50 W!

Electrode à main autorisée seulement jusqu'à 50 W max.!

Cilindro a mano omologato solo sino al max. 50 W!

80-310-04

Handzylinder-Neutralelektrode mit 4 m Kabel

Hand cylinder neutral electrode with connection cable of 4 m

Placa neutra en forma de cilindro con cable de conexión de 4 m

Electrode neutre en forme de cylindre avec câble de raccordement de 4 m

Elettrodo neutro a forma cilindrica con cavo di connessione da 4 m

Zubehör für MD 62

Accessories for MD 62
 Accesorios para MD 62
 Accessoires pour MD 62
 Accessori per MD 62

HF-Chirurgie

HF Surgery
 Cirugía AF
 Chirurgie HF
 Chirurgia AF

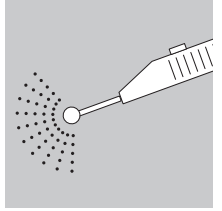

Elektroden mit Ø 1,6 mm	Drahtstärke der Drahtschlingenelektroden	= Ø 0,2 mm
Electrodes Ø 1.6 mm	Wire size of wire loop electrodes	= Ø 0.2 mm
Electrodos con Ø 1,6 mm	Grosor del alambre del electrodo de asa	= Ø 0,2 mm
Electrodes Ø 1,6 mm	Epaisseur du fil des électrodes anse	= Ø 0,2 mm
Elettrodi Ø 1,6 mm	Spessore filo degli elettrodi ad ansa	= Ø 0,2 mm



80-461-01

Nadelelektrode, gerade, Fig. 1
 Needle electrode, straight, Fig. 1
 Electrodo de aguja, recto, fig. 1
 Electrode aiguille, droite, fig. 1
 Elettrodo ad ago, retto, fig. 1



80-461-02

Nadelelektrode, 45° abgewinkelt, Fig. 2
 Needle electrode, 45° angled, Fig. 2
 Electrodo de aguja, acodado 45°, fig. 2
 Electrode aiguille, coudée en 45°, fig. 2
 Elettrodo ad ago, angolo 45°, fig. 2



80-461-12

Drahtschlingenelektrode, Fig. 12
 Wire loop electrode, Fig. 12
 Electrodo de asa de alambre, fig. 12
 Electrode anse, fig. 12
 Elettrodo ad ansa, fig. 12



80-461-14

Drahtschlingenelektrode, rhombusförmig, 8 x 5 mm, Fig. 14
 Wire loop electrode, rhombic, 8 x 5 mm, Fig. 14
 Electrodo de asa de alambre romboidal, 8 x 5 mm, fig. 14
 Electrode anse, romboidale, 8 x 5 mm, fig. 14
 Elettrodo ad ansa a forma di rombo, 8 x 5 mm, fig. 14



80-461-15

Drahtschlingenelektrode, länglich, 7,0 x 1,5 mm,
 Schaft 45° abgewinkelt, Fig. 15

Wire loop electrode, elongated, 7.0 x 1.5 mm,
 shaft 45° angled, Fig. 15

Electrodo de asa de alambre oblonga, 7,0 x 1,5 mm,
 vástago acodado 45°, fig.15

Electrode anse, forme allongée, 7,0 x 1,5 mm,
 tige coudée en 45°, fig. 15

Elettrodo ad ansa retta, 7,0 x 1,5 mm,
 asta curva a 45°, fig. 15



80-461-31

Koagulations-Nadelelektrode, Ø 0,6 mm,
 45° abgewinkelt, Fig. 31

Needle electrode for coagulation, Ø 0.6 mm,
 45° angled, Fig. 31

Electrodo de aguja para la coagulación, Ø 0,6 mm,
 acodado 45°, fig. 31

Electrode aiguille pour la coagulation, Ø 0,6 mm,
 coudée en 45°, fig. 31

Elettrodo ad ago per coagulazione Ø 0,6 mm,
 asta curva a 45°, fig. 31



80-461-34

Kugelelektrode, 45° abgewinkelt, Fig. 34
 Ball electrode, 45° angled, Fig. 34

Electrodo de bola, 45° acodado, fig. 34

Electrode boule, coudée en 45°, fig. 34

Elettrodo a sfera, asta curva a 45°, fig. 34

Elektrochirurgie-Gerät Minicutter

Electrosurgical unit Minicutter

Aparato electroquirúrgico Minicutter

Appareil électrochirurgical Minicutter

Apparecchio elettrochirurgico Minicutter



KLS Martin Minicutter Das Allround-Talent

Der Minicutter ist mit seiner Ausgangsleistung von 80 Watt in der monopolaren und 70 Watt in der bipolaren Technik das ideale Gerät für Ambulanz und Praxis. Sein breites Anwendungsspektrum macht ihn zu einem wahren Allrounder sowohl in der Klinik als auch im niedergelassenen Bereich.

KLS Martin Minicutter The all-rounder

With an output power of 80 watts in monopolar and 70 watts in bipolar mode, the Minicutter is simply ideal for outpatient departments and private surgeries. Thanks to its wide application range, the Minicutter is a true all-rounder for use in hospitals and private practices alike.

KLS Martin Minicutter El multitalento

El Minicutter, con su potencia de salida de 80 vatios en la técnica monopolar y de 70 vatios en la técnica bipolar, es el equipo ideal para el ambulatorio y el consultorio médico. Su amplio espectro de aplicación en los ámbitos lo convierten en un verdadero multitalento, tanto en la clínica como también en los consultorios privados.

Die wichtigsten Vorzüge des Minicutter im Überblick:

- Kompaktes und leistungsfähiges HF-Chirurgiegerät mit 2 Schneide- und 3 Koagulationsströmen, universell einsetzbar in unterschiedlichen Fachdisziplinen.
- Leistungsstarker Bipolarteil für ein breites Spektrum bipolarer HF-Instrumente.
- Unkomplizierte und sichere Handhabung. Äußerst zuverlässige und robuste Grundkonzeption mit höchsten Qualitätsstandards.
- Schnelle und komfortable Bedienbarkeit mittels Drehregler und anwenderfreundlicher Folientastatur.
- Hohe Patientensicherheit durch Schutz vor Überdosierung und Neutralelektrodenüberwachung. Bei Verwendung einer zweifächigen Neutralelektrode führt der Minicutter eine ständige Neutralelektrodenüberwachung durch.

The Minicutter's main advantages at a glance:

- Compact yet powerful HF surgical unit offering two cutting and three coagulation currents that are universally applicable across many different medical fields.
- Powerful bipolar part for a wide range of bipolar HF instruments.
- Uncomplicated and safe handling. Sound, extremely dependable design based on the highest quality standards.
- Fast and convenient operation thanks to rotary switch and user-friendly membrane keypad.
- High patient safety due to overdosage protection and neutral electrode monitoring. When using a split neutral electrode, the Minicutter provides constant NE monitoring for increased safety.

Las ventajas más importantes del Minicutter a simple vista:

- Equipo de cirugía de AF compacto y eficiente con 2 corrientes de corte y 3 de coagulación, de aplicación universal en las especialidades más diversas.
- Funciones bipolares de alto rendimiento para un espectro amplio de instrumental de AF bipolar.
- Manejo sencillo y seguro. Concepto básico extremadamente fiable y robusto con los máximos estándares de calidad.
- Operación rápida y confortable gracias al mando giratorio y al claro teclado laminar.
- Alta seguridad del paciente gracias a la protección ante sobredosificación y al control de la placa neutra. Al utilizar una placa neutra dividida, el Minicutter realiza un control constante de la placa neutra.

Elektrochirurgie-Gerät Minicutter

Electrosurgical unit Minicutter

Aparato electroquirúrgico Minicutter

Appareil électrochirurgical Minicutter

Apparecchio elettrochirurgico Minicutter

HF-Chirurgie

HF Surgery

Cirurgía AF

Chirurgie HF

Chirurgia AF

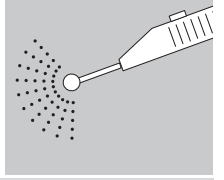

KLS Martin Minicutter Le talent multiple

Avec une puissance de sortie de 80 watts en mode monopolaire et de 70 watts en mode bipolaire, le Minicutter est tout simplement l'appareil idéal pour l'ambulance et le cabinet médical. Son domaine d'application extrêmement large fait de lui l'instrument à talents multiples par excellence, à l'hôpital comme au sein des cabinets médicaux privés.

KLS Martin Minicutter – Il talento a tutto tondo per eccellenza

Con una potenza in uscita pari a 80 watt nella tecnica monopolare e a 70 watt nella tecnica bipolare, il dispositivo Minicutter rappresenta l'apparecchio ideale per l'attività in ambulanza e negli studi medici. La sua ampia gamma di applicazioni fa di questo apparecchio uno strumento estremamente versatile, ideale per l'utilizzo in clinica nonché per l'attività negli studi medici.

Les principaux avantages du Minicutter en quelques lignes:

- Appareil de chirurgie compact et performant, offrant 2 courants de coupure et 3 courants de coagulation, applicable de façon universelle dans de nombreux domaines médicaux différents.
- Constitue un élément bipolaire performant pour un large éventail d'instruments bipolaires HF.
- Utilisation simple et sûre. Conception de base extrêmement fiable et robuste, fondée sur les standards de qualité les plus élevés.
- Réglage rapide et confortable grâce à son bouton rotatif et à son clavier à effleurement particulièrement convivial.
- Sécurité accrue pour le patient grâce à son système de protection contre les surdosages et à la surveillance continue de l'électrode neutre. Lorsqu'une électrode neutre à deux faces est utilisée, elle est surveillée en permanence par le Minicutter.

Sintesi dei principali vantaggi del dispositivo Minicutter:

- Apparecchio chirurgico AF compatto ed efficiente, dotato di 2 correnti di taglio e 3 correnti di coagulazione, a utilizzo universale in diverse discipline tecniche.
- Potente componente bipolare per un ampio assortimento di strumenti AF bipolari.
- Praticità e sicurezza di utilizzo. Estrema efficienza e robustezza della struttura di base con i massimi standard in termini di qualità.
- Praticità e rapidità di utilizzo grazie alla manopola ed alla comoda tastiera.
- Elevate condizioni di sicurezza per il paziente grazie al sistema di protezione contro dosaggi eccessivi, nonché al sistema di controllo degli elettrodi neutri. In caso di utilizzo di un elettrodo neutro a due superfici, l'apparecchio Minicutter esegue un costante controllo degli elettrodi neutri.

80

Zubehörsätze für Minicutter

Accessory sets for Minicutter

Juegos de accesorios para Minicutter

Jeux d'accessoires pour Minicutter

Serie di accessori per Minicutter



80-008-03

Elektrochirurgie-Gerät Minicutter
Electrosurgical unit Minicutter
Aparato electroquirúrgico Minicutter
Appareil électrochirurgical Minicutter
Apparecchio elettrochirurgico Minicutter

Technische Daten Minicutter		Technical data Minicutter		Características técnicas Minicutter	
HF-Ausgangsgrößen:		HF outputs:		Potencias de AF:	
CUT 1	Pure, unmoduliert 80 W 300 Ω	CUT 1	pure cut, unmodulated 80 W300 Ω	CUT 1	pure, sin modular 80 W300 Ω
CUT 2	Blend, moduliert 70 W 300 Ω	CUT 2	blend cut, modulated 70 W300 Ω	CUT 2	blend, modulado 70 W300 Ω
CONTACT COAG	Kontakt 70 W 200 Ω	CONTACT COAG	contact 70 W200 Ω	CONTACT COAG	contacto 70 W200 Ω
SPRAY COAG	Spray 60 W 400 Ω	SPRAY COAG	spray 60 W400 Ω	SPRAY COAG	spray 60 W400 Ω
BIPOLAR COAG	Bipolar 70 W 50 Ω	BIPOLAR COAG	bipolar 70 W 50 Ω	BIPOLAR COAG	bipolar 70 W 50 Ω
Nennfrequenz	1230/920/460 kHz	Nominal frequencies	1230/920/460 kHz	Frecuencia nominal	1230/920/460 kHz
Modulationsfrequenz	77/58 kHz	Modulation frequency	77/58 kHz	Frecuencia de modulación	77/58 kHz
Netzspannung	100-127/220-240 V, 50/60 Hz	Supply voltage	100-127 / 220-240 V, 50/60 Hz	Tensión de alimentación	100-127/220-240 V, 50/60 Hz
Gerätetyp	BF; defibrillationsfest	Type (of applied part)	BF; defibrillation-proof	Tipo de equipo	BF, protegido contra los choques de desfibrilación
Schutzklasse	I (DIN EN 60601-1)	Protection class	I (DIN EN 60601-1)	Clase de protección	I (DIN EN 60601-1)
Geräteklasse	IIb nach MPG	Device class	IIb (acc. to MDD/Med. Dev. Act)	Categoría de equipo	IIb según la DPS
Abmessungen	270 x 120 x 250 mm (B x H x T)	Dimensions	270 x 120 x 250 mm (W x H x D)	Dimensiones	270 x 120 x 250 mm (A x Al x P)
Gewicht	3,7 kg	Weight	3.7 kg	Peso	3,7 kg
Qualitätssicherung nach DIN EN ISO 9001 / 13485		Quality assurance acc. to DIN EN ISO 9001 / 13485		Aseguramiento de la calidad conforme con DIN EN ISO 9001 / 13485	
CE-Kennzeichnung	konform mit 93/42/EWG	CE marking	conform with 93/42/EEC	Marcación CE	conforme con 93/42/CEE

80-108-03	Satz monopolarer Zubehör Minicutter, Hand, groß, bestehend aus:	Accessory set monopolar for Minicutter for hand switch operation, large, consisting of:	Juego de accesorios monopolarer Minicutter con interruptor digital, grande, compuesto de:
80-217-01	1 Handgriff mit einer Taste, 4 m Kabel	- Electrode handle with one pushbutton and connection cable of 4 m	- Mango porta-electrodos con una tecla y cable de conexión de 4 m
80-332-03	1 Gummi-Neutralelektrode 8 x 16 cm, 4 m Kabel	- Rubber neutral electrode, 8 x 16 cm, with connection cable of 4 m	- Placa neutra de goma, 8 x 16 cm, cable de conexión de 4 m
80-370-50	1 Gummibinde, gelocht, 50 cm	- Rubber band, with holes, 50 cm	- Cinta de goma, perforada, 50 cm
80-371-01	1 Knopf für Gummibinde	- Button for rubber band	- Botón para la cinta de goma
80-408-00	1 Elektroden-Ständer für 8 Elektroden	- Electrode box for 8 electrodes	- Caja para 8 electrodos
80-510-04	1 Lanzettelektrode, gerade	- Lancet electrode, straight	- Electrodo de lanceta, recto
80-515-04	1 Messerelektrode	- Knife electrode	- Electrodo de cuchillo
80-520-04	1 Nadelelektrode	- Needle electrode	- Electrodo de aguja
80-525-04	1 Dtz. Nadelelektroden, extra fein	- Doz. needle electrodes, extra fine	- Docena de electrodos de aguja, especialmente finos
80-532-00	1 Reduz.-Stück für Nadelelektroden	- Adapter for needle electrodes	- Adaptador para electrodos de aguja
80-540-04	1 Drahtschlingenelektrode, Ø 5 mm	- Wire loop electrode, Ø 5 mm	- Electrodo de asa de alambre, Ø 5 mm
80-542-04	1 Drahtschlingenelektrode, Ø 10 mm	- Wire loop electrode, Ø 10 mm	- Electrodo de asa de alambre, Ø 10 mm
80-560-04	1 Kugelelektrode, Ø 2 mm	- Ball electrode, Ø 2 mm	- Electrodo de bola, Ø 2 mm
80-562-04	1 Kugelelektrode, Ø 4 mm	- Ball electrode, Ø 4 mm	- Electrodo de bola, Ø 4 mm

Zubehörsätze für Mincutter

Accessory sets for Mincutter
Juegos de accesorios para Mincutter
Jeux d'accessoires pour Mincutter
Serie di accessori per Mincutter

HF-Chirurgie

HF Surgery
Cirugía AF
Chirurgie HF
Chirurgia AF

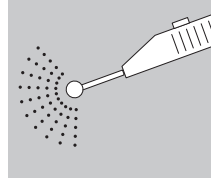

Données techniques Mincutter

Dati tecnici Mincutter

Valeurs de sortie HF:			Dimensioni dell'uscita AF:		
CUT 1	Pure, non-modulée	80 W 300 Ω	CUT 1	Pure, non modulato	80 W 300 Ω
CUT 2	Blend, modulée	70 W 300 Ω	CUT 2	Blend, modulato	70 W 300 Ω
CONTACT COAG	Coagulation douce	70 W 200 Ω	CONTACT COAG	Con contatto	70 W 200 Ω
SPRAY COAG	Vaporisation	60 W 400 Ω	SPRAY COAG	A spruzzo	60 W 400 Ω
BIPOLAR COAG	Bipolaire	70 W 50 Ω	BIPOLAR COAG	Bipolare	70 W 50 Ω
Fréquence nominale	1230/920/460 kHz		Frequenza nominale	1230/920/460 kHz	
Fréquence de modulation	77/58 kHz		Frequenza di modulazione	77/58 kHz	
Tension de réseau	100-127 / 220-240 V, 50/60 Hz		Tensione di rete	100-127/220-240 V, 50/60 Hz	
Type d'appareil	BF; résistant à la défibrillation		Modello di apparecchio	BF; non interferisce con il funzionamento dei defibrillatori	
Classe de protection	I (DIN EN 60601-1)		Classe di protezione	I (DIN EN 60601-1)	
Classification de l'appareil	IIb, selon la Loi allemande sur les produits médicaux (MPG)		Classe dell'apparecchio	IIb secondo la normativa per apparecchi a uso medico MDD	
Dimensions	270 x 120 x 250 mm (L x H x P)		Dimensioni	270 x 120 x 250 mm (Largh. x A x P)	
Poids	3.7 kg		Peso	3,7 kg	
Assurance de qualité d'après la norme DIN EN ISO 9001 / 13485			Assicurazione della qualità ai sensi della normativa DIN EN ISO 9001/13485		
Marquage CE	conforme à 93/42/CEE		Marcatura CE	secondo le norme 93/42/CEE	

80

80-108-03 Grand lot d'accessoires monopolaires Mincutter pour commande digitale, composé de:

Serie grande di accessori monopolari standard Mincutter, per attivazione a mano, composta di:

80-217-01	1	Manche porte-électrodes avec interrupteur digital et câble de raccordement de 4 m	-	Manico portaelettrodi con interruttore e cavo di connessione di 4 m
80-332-03	1	Electrode neutre en caoutchouc, 8 x 16 cm, avec câble de raccordement de 4 m	-	Elettrodo neutro di gomma, 8 x 16 cm, cavo di connessione di 4 m
80-370-50	1	Bande caoutchouc, perforée, 50 cm	-	Nastro di gomma, perforato, 50 cm
80-371-01	1	Bouton pour bande caoutchouc	-	Bottone per nastro di gomma
80-408-00	1	Boîte pour 8 électrodes	-	Supporto per 8 elettrodi in scatola
80-510-04	1	Electrode lancette, droite	-	Elettrodo a lancetta, retto
80-515-04	1	Electrode couteau	-	Elettrodo a bisturi
80-520-04	1	Electrode aiguille	-	Elettrodo ad ago
80-525-04	1	Douz. d'électrodes aiguille, extra fines	-	Elettrodo ad ago, strafino, dozz.
80-532-00	1	Adaptateur pour électrodes aiguille	-	Adattatore per elettrodi ad ago
80-540-04	1	Electrode anse en fil, Ø 5 mm	-	Elettrodo ad ansa, Ø 5 mm
80-542-04	1	Electrode anse en fil, Ø 10 mm	-	Elettrodo ad ansa, Ø 10 mm
80-560-04	1	Electrode boule, Ø 2 mm	-	Elettrodo a sfera, Ø 2 mm
80-562-04	1	Electrode boule, Ø 4 mm	-	Elettrodo a sfera, Ø 4 mm

Elektrochirurgie-Gerät ME 102

Electrosurgical unit ME 102

Aparato electroquirúrgico ME 102

Appareil électrochirurgical ME 102

Apparecchio elettrochirurgico ME 102



KLS Martin ME 102 Unser kompaktes Elektrochirurgie- Gerät mit der großen Leistung

Das KLS Martin ME 102 ist ein universell einsetzbares HF-Elektrochirurgie-Gerät der 100-Watt-Klasse mit hervorragenden Schneide- und Koagulations-eigenschaften. Seine Konzeption ist auf die besonderen Ansprüche der ambulanten und der klinischen Anwendung ausgerichtet.

KLS Martin ME 102 The compact electrosurgical unit with high capacity

The KLS Martin ME 102 is a 100-W class, universally applicable HF electrosurgical unit with excellent cutting and coagulation characteristics. It has been designed to satisfy the special demands of clinical and outpatient applications.

KLS Martin ME 102 Nuestro equipo de electrocirugía compacto de gran potencia

El KLS Martin ME 102 es un equipo de electrocirugía AF de aplicación universal dentro de la categoría de los 100 W, con excelentes características de corte y coagulación. Se ha concebido para satisfacer las exigencias especiales de la aplicación ambulatoria y clínica.

Die Eigenschaften im Überblick:

- Glattes und verschorftes Schneiden durch 100-Watt-Power-Generator
- Bipolarer Funktionsblock mit 80-W-Leistung
- Automatische Anpassung an unterschiedliche Schnittgeschwindigkeiten und Gewebe-impedanzen
- Kontaktkoagulation zur schnellen Blutstillung
- HF-Aktivierung über Handschalter oder Fußschalter
- Präzise Dosierbarkeit durch stufenlose Leistungsregelung für jede Betriebsart
- Unkomplizierte und sichere Handhabung
- Frontfolienaufteilung nach Funktionsblöcken
- Mikroschalter zur Feinstchirurgie
- Neutralelektrodenüberwachung durch NE-Monitoring
- Bipolare „Auto-Coag-Start“-Funktion
- Schaltungsart CF für höchste Patientensicherheit
- Memory-Funktion

Features at a glance:

- Smooth or scabbed cut thanks to 100-W power generator
- 80-W bipolar output power
- Automatic power adaptation to different cutting speeds and tissue impedances
- Contact coagulation for fast hemostasis
- HF activation via manual switch or foot switch
- High-precision dosage thanks to stepless output power regulation for any mode of operation
- Easy and safe handling
- Clear front panel layout
- MICRO switch for high-precision and micro-surgery
- Neutral-electrode (NE) monitoring
- Bipolar „Auto-Coag-Start“ function
- CF-type connection for utmost patient safety
- Memory function

Buenas razones para su elección:

- Corte limpio y escarificado mediante el generador de 100 W de potencia
- Bloque de funcionamiento bipolar con 80 W de potencia
- Adaptación dinámica a diferentes velocidades de corte e impedancias de tejido
- Coagulación por contacto para calmar rápidamente la hemorragia
- Activación AF a través de interruptor manual o de pedal
- Dosificación precisa gracias a la regulación de potencia de progresión continua para cada modo de servicio
- Manejo sencillo y seguro
- División de la lámina frontal en base a los bloques funcionales
- Microinterruptor para cirugía de precisión
- Control de la placa neutra
- Función bipolar „Auto-Coag-Start“
- Tipo de conmutación CF para la máxima seguridad del paciente
- Función de memoria

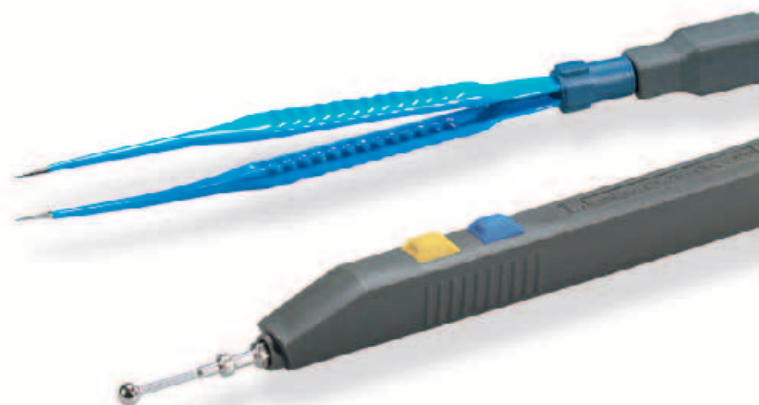
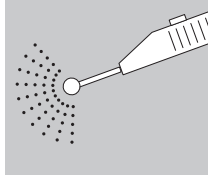

KLS Martin ME 102 Notre appareil d'électrochirurgie compact et de haute performance

L'appareil KLS Martin ME 102 est un instrument d'électro-chirurgie HF de la catégorie 100 watt, à emploi universel et aux excellentes propriétés de coupe et de coagulation. Il a été spécialement conçu pour répondre aux exigences particulières de l'application ambulatoire et clinique.

KLS Martin ME 102 L'apparecchio elettrochirurgico compatto ad elevata potenza

L'apparecchio elettrochirurgico KLS Martin ME 102 può essere impiegato in modo universale per la chirurgia AF. Con una potenza di 100 Watt offre eccezionali caratteristiche di taglio e coagulazione. La sua concezione è orientata principalmente alle particolari esigenze degli ambulatori e delle cliniche.

De bonnes raisons de choisir:

- Coupe lisse et escarifiée grâce au générateur puissant de 100 watt
- Bloc fonctionnel bipolaire avec 80 W de puissance
- Adaptation automatique à différentes vitesses de coupe et impédances de tissu
- Coagulation de contact pour arrêter rapidement les saignements
- Activation HF par l'intermédiaire d'un interrupteur manuel ou à pied
- Dosage précis par réglage de puissance sans paliers pour chaque mode opératoire
- Manipulation simple et sûre
- Division de la plaque frontale en blocs fonctionnels
- Interrupteur micro pour chirurgie très fine
- Surveillance des électrodes neutres grâce à un monitoring NE
- Fonction bipolaire «Départ auto-coag.»
- Mode de commande CF assurant la plus grande sécurité au patient
- Fonction mémoire

Tanti buoni motivi in sintesi:

- Taglio piatto e con formazione di escara grazie al generatore con una potenza di 100 Watt
- Blocco funzioni bipolare con potenza di 80 Watt
- Adattamento automatico alle diverse velocità di taglio e impedenze del tessuto
- Coagulazione a contatto per una rapida emostasi
- Attivazione AF mediante interruttore manuale o interruttore a pedale
- Precisa regolazione del dosaggio grazie al dispositivo di regolazione continua per ogni modo operativo
- Utilizzo semplice e sicuro
- Ripartizione del pannello frontale a seconda dei blocchi funzione
- Microinterruttore per la chirurgia di precisione
- Sorveglianza dell'elettrodo neutro mediante monitoraggio NE
- Funzione "Auto-Koag-Start" bipolare
- Modo operativo CF per la massima sicurezza del paziente
- Funzione Memory

Zubehörsätze für ME 102

Accessory sets for ME 102

Juegos de accesorios para ME 102

Jeux d'accessoires pour ME 102

Serie di accessori per ME 102



80-010-02

Elektrochirurgie-Gerät ME 102

Electrosurgical unit ME 102

Aparato electroquirúrgico ME 102

Appareil électrochirurgical ME 102

Apparecchio elettrochirurgico ME 102

Technische Daten ME 102		Technical data ME 102		Características técnicas ME 102	
Stromart Makro Mode		Type of current: Macro Mode		Tipo de corriente: Makro Mode	
Schneiden 1:	100 Watt an 600 Ω	Cut 1:	100 Watt at 600 Ω	Corte 1	100 W a 600 Ω
Schneiden 2:	90 Watt an 600 Ω	Cut 2:	90 Watt at 600 Ω	Corte 2	90 W a 600 Ω
Kontaktkoagulation:	70 Watt an 600 Ω	Contact coagulation:	70 Watt at 600 Ω	Coagulación por contacto	70 W a 600 Ω
Bipolare Koagulation:	80 Watt an 100 Ω	Bipolar coagulation:	80 Watt at 100 Ω	Coagulación bipolar	80 W a 100 Ω
Stromart Mikro Mode		Type of current: Micro Mode		Tipo de corriente: Micro Mode	
Schneiden 1:	30 Watt an 600 Ω	Cut 1:	30 Watt at 600 Ω	Corte 1	30 W a 600 Ω
Schneiden 2:	30 Watt an 600 Ω	Cut 2:	30 Watt at 600 Ω	Corte 2	30 W a 600 Ω
Kontaktkoagulation:	25 Watt an 600 Ω	Contact coagulation:	25 Watt at 600 Ω	Coagulación por contacto	25 W a 600 Ω
Bipolare Koagulation:	25 Watt an 100 Ω	Bipolar coagulation:	25 Watt at 100 Ω	Coagulación bipolar	25 W a 100 Ω
Netzanschluss:	100-127 V, 50-60 Hz 220-240 V, 50-60 Hz	Mains voltage/power supply:	100-127 V, 50-60 Hz 220-240 V, 50-60 Hz	Voltaje	100-127 VAC, 50-60 Hz 220-240 VAC, 50-60 Hz
Typ:	CF, defibrillationsfest	Type:	CF, defibrillation proof	Tipo de equipo	CF; resistente a la presencia de un desfibrilador
Schutzklasse:	I	Class of protection:	I	Clase de protección	I
Medizinprodukt der Klasse:	II b	Medical product of class:	II b	Clasificación según MPG	II b
CE-Kennzeichnung	konform mit 93/42/EWG	CE marking	conform with 93/42/EEC	Marcación CE	conforme con 93/42/CEE

80-108-00	Satz monopolarer Zubehör ME 102, Hand, groß, bestehend aus:	Accessory set monopolar for ME 102 for hand switch operation, large, consisting of:	Juego de accesorios monopolarer ME 102 con interruptor digital, grande, compuesto de:
80-217-01	1 Handgriff mit einer Taste, 4 m Kabel	- Electrode handle with one pushbutton and connection cable of 4 m	- Mango porta-electrodos con una tecla y cable de conexión de 4 m
80-332-03	1 Gummi-Neutralelektrode 8 x 16 cm, 4 m Kabel	- Rubber neutral electrode, 8 x 16 cm, with connection cable of 4 m	- Placa neutra de goma, 8 x 16 cm, cable de conexión de 4 m
80-370-50	1 Gummibinde, gelocht, 50 cm	- Rubber band, with holes, 50 cm	- Cinta de goma, perforada, 50 cm
80-371-01	1 Knopf für Gummibinde	- Button for rubber band	- Botón para la cinta de goma
80-408-00	1 Elektroden-Ständer für 8 Elektroden	- Electrode box for 8 electrodes	- Caja para 8 electrodos
80-510-04	1 Lanzettelektrode, gerade	- Lancet electrode, straight	- Electrodo de lanceta, recto
80-515-04	1 Messerelektrode	- Knife electrode	- Electrodo de cuchillo
80-520-04	1 Nadelelektrode	- Needle electrode	- Electrodo de aguja
80-525-04	1 Dtz. Nadelelektroden, extra fein	- Doz. needle electrodes, extra fine	- Docena de electrodos de aguja, especialmente finos
80-532-00	1 Reduz.-Stück für Nadelelektroden	- Adapter for needle electrodes	- Adaptador para electrodos de aguja
80-540-04	1 Drahtschlingenelektrode, Ø 5 mm	- Wire loop electrode, Ø 5 mm	- Electrodo de asa de alambre, Ø 5 mm
80-542-04	1 Drahtschlingenelektrode, Ø 10 mm	- Wire loop electrode, Ø 10 mm	- Electrodo de asa de alambre, Ø 10 mm
80-560-04	1 Kugelelektrode, Ø 2 mm	- Ball electrode, Ø 2 mm	- Electrodo de bola, Ø 2 mm
80-562-04	1 Kugelelektrode, Ø 4 mm	- Ball electrode, Ø 4 mm	- Electrodo de bola, Ø 4 mm

Zubehörsätze für ME 102

Accessory sets for ME 102
Juegos de accesorios para ME 102
Jeux d'accessoires pour ME 102
Serie di accessori per ME 102

HF-Chirurgie

HF Surgery
Cirugía AF
Chirurgie HF
Chirurgia AF

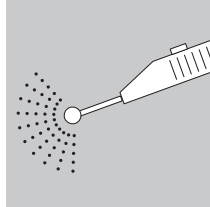

Données techniques ME 102

Dati tecnici ME 102

Type de courant: Mode macro

Coupe 1	100 W pour 600 Ω
Coupe 2	90 W pour 600 Ω
Coagulation de contact	70 W pour 600 Ω
Coagulation bipolaire	80 W pour 100 Ω

Tipo di corrente: Modo Macro

Taglio 1	100 W 600 Ω
Taglio 2	90 W 600 Ω
Coagulazione a contatto	70 W 600 Ω
Coagulazione bipolare	80 W 100 Ω

Type de courant: Mode micro

Coupe 1	30 W pour 600 Ω
Coupe 2	30 W pour 600 Ω
Coagulation de contact	25 W pour 600 Ω
Coagulation bipolaire	25 W pour 100 Ω
Fusibles de secteur	100-127 V, 50-60 Hz 220-240 V, 50-60 Hz

Tipo di corrente: Modo Micro

Taglio 1	30 W 600 Ω
Taglio 2	30 W 600 Ω
Coagulazione a contatto	25 W 600 Ω
Coagulazione bipolare	25 W 100 Ω
Fusibili di rete	100-127 V, 50-60 Hz 220-240 V, 50-60 Hz

Type	CF, résistant à la défibrillation
Catégorie de protection	I
Classification selon Loi sur produits médicaux	II b
Marquage CE	conforme à 93/42/CEE

Tipo di apparecchio	CF, non interferisce con i defibrillatori
Classe di protezione	I
Classificazione secondo MPG	II b
Marcatura CE	secondo le norme 93/42/CEE

80

80-108-00 Grand lot d'accessoires monopolaires ME 102 pour commande digitale, composé de:

Serie grande di accessori monopolari standard ME 102, per attivazione a mano, composta di:

80-217-01	1	Manche porte-électrodes avec interrupteur digital et câble de raccordement de 4 m	- Manico portaelettrodi con interruttore e cavo di connessione di 4 m
80-332-03	1	Electrode neutre en caoutchouc, 8 x 16 cm, avec câble de raccordement de 4 m	- Elettrodo neutro di gomma, 8 x 16 cm, cavo di connessione di 4 m
80-370-50	1	Bande caoutchouc, perforée, 50 cm	- Nastro di gomma, perforato, 50 cm
80-371-01	1	Bouton pour bande caoutchouc	- Bottone per nastro di gomma
80-408-00	1	Boîte pour 8 électrodes	- Supporto per 8 elettrodi in scatola
80-510-04	1	Electrode lancette, droite	- Elettrodo a lancetta, retto
80-515-04	1	Electrode couteau	- Elettrodo a bisturi
80-520-04	1	Electrode aiguille	- Elettrodo ad ago
80-525-04	1	Douz. d'électrodes aiguille, extra fines	- Elettrodo ad ago, strafino, dozz.
80-532-00	1	Adaptateur pour électrodes aiguille	- Adattatore per elettrodi ad ago
80-540-04	1	Electrode anse en fil, Ø 5 mm	- Elettrodo ad ansa, Ø 5 mm
80-542-04	1	Electrode anse en fil, Ø 10 mm	- Elettrodo ad ansa, Ø 10 mm
80-560-04	1	Electrode boule, Ø 2 mm	- Elettrodo a sfera, Ø 2 mm
80-562-04	1	Electrode boule, Ø 4 mm	- Elettrodo a sfera, Ø 4 mm

Zubehör für Minicutter und ME 102

Accessories for Minicutter and ME 102

Accesorios para Minicutter y ME 102

Accessoires pour Minicutter et ME 102

Accessori per Minicutter e ME 102



80-217-02 – KLS Martin/Aesculap/Berchtold

Elektroden-Handgriff mit zwei Tasten, großem Koax-Stecker und 4 m Anschlusskabel

Electrode handle with two pushbuttons, large coax plug and connection cable of 4 m

Mango porta-electrodos con dos teclas, clavija coaxial grande y cable de conexión de 4 m

Manche porte-électrodes avec interrupteur digital double, grande fiche coax et câble de raccordement de 4 m

Manico portaelettrodi con due tasti, spina coassiale grande e cavo di connessione da 4 m



80-332-03

8 x 16 cm

Gummi-Neutralelektrode für Kinder, ungeteilte Kontaktfläche 128 cm²

Rubber neutral electrode for children, single contact surface, 128 cm²

Placa neutra de goma para niños, superficie de contacto no dividida, 128 cm²

Electrode neutre en caoutchouc pour enfants, surface de contact non divisée 128 cm²

Elettrodo neutro di gomma per bambini, superficie integrale di contatto da 128 cm²



80-408-00

für 8 Elektroden mit Schaft Ø 4 mm

for 8 electrodes with shaft Ø 4 mm

para 8 electrodos con vástago de Ø de 4 mm

pour 8 électrodes à tige de Ø 4 mm

per 8 elettrodi con asta di Ø 4 mm



80-370-50 = 50 cm/20"

80-371-00 = 100 cm/40"

Gummibinden, gelocht

Rubber bands, with holes

Cintas de goma, perforadas

Bandes caoutchouc, perforées

Nastri in gomma, con fori



80-371-01

Knopf für Gummibinde 80-370-50 + 80-371-00

Button for rubber band 80-370-50 + 80-371-00

Botón para la cinta de goma 80-370-50 + 80-371-00

Bouton pour bande caoutchouc 80-370-50 + 80-371-00

Bottone per nastro in gomma 80-370-50 + 80-371-00

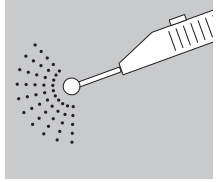

KLS-Martin-Edelstahlelektroden

KLS Martin stainless steel electrodes

Electrodos KLS Martin de acero inoxidable

Electrodes KLS Martin en acier inoxydable

Elettrodi KLS Martin in acciaio inox

Aktivelektroden mit Ø 4 mm

Active electrodes Ø 4 mm

Electrodos activos con Ø 4 mm

Electrodes actives Ø 4 mm

Elettrodi attivi Ø 4 mm

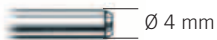

80-510-04

Lanzettelektrode, gerade
Lancet electrode, straight
Electrodo de lanceta, recto
Electrode lancette, droite
Elettrodo a lancetta, retto



80-515-04

Messerelektrode
Knife electrode
Electrodo de cuchillo
Electrode couteau
Elettrodo a bisturi



80-520-04

Nadelelektrode
Needle electrode
Electrodo de aguja
Electrode aiguille
Elettrodo ad ago



80-540-04 = Ø 5 mm

80-542-04 = Ø 10 mm

Drahtschlingenelektrode
Wire loop electrode
Electrodo de asa de alambre
Electrode anse en fil
Elettrodo ad ansa di filo



80-560-04 = Ø 2 mm

80-562-04 = Ø 4 mm

Kugelelektrode
Ball electrode
Electrodo de bola
Electrode boule
Elettrodo a sfera

Elektroden mit Ø 0,8 mm

Electrodes Ø 0.8 mm

Electrodos con Ø 0,8 mm

Electrodes Ø 0,8 mm

Elettrodi Ø 0,8 mm

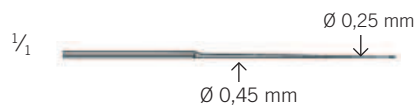

80-525-04

Nadelelektrode, 1 Dutzend
Needle electrode, 1 dozen
Electrodo de aguja, 1 docena
Electrode aiguille, 1 douzaine
Elettrodo ad ago, 1 dozzina

nicht isoliert
non-insulated
no aislado
pas isolée
non isolato



80-532-00

Adapter von	Ø 4 mm	auf	Ø 0,8 mm	für	80-525-04/80-536-04
Adapter from	Ø 4 mm	to	Ø 0.8 mm	for	80-525-04/80-536-04
Adaptador de	Ø 4 mm	a	Ø 0,8 mm	para	80-525-04/80-536-04
Adaptateur de	Ø 4 mm	à	Ø 0,8 mm	pour	80-525-04/80-536-04
Adattatore da	Ø 4 mm	a	Ø 0,8 mm	per	80-525-04/80-536-04



80-811-50

Monopolarer und bipolarer Fußschalter, explosionsgeschützt, AP-geprüft
Monopolar and bipolar foot switch, anti-explosive, AP-tested (anesthetics-proof)
Interruptor de pie monopolar y bipolar, antiexplosivo, controlada su aptitud para anestésicos
Interrupteur à pédale monopolaire et bipolaire, anti-explosif, catégorie AP
Interruttore a pedale monopolare e bipolare, anti-deflagrante, testato AP

Zubehör für Minicutter und ME 102

Accessories for Minicutter and ME 102

Accesorios para Minicutter y ME 102

Accessoires pour Minicutter et ME 102

Accessori per Minicutter e ME 102



80-925-16

16 cm/6 1/4"

Bipolare Pinzette, gewinkelt
Bipolar forceps, angled
Pinza bipolar, acodada
Pince bipolaire, coudée
Pinza bipolare, piegata

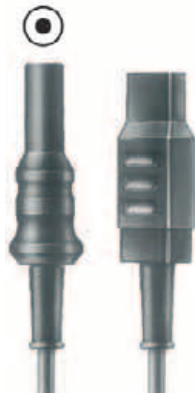

80-287-53

5 m/16 ft.

Anschlusskabel für bipolare Instrumente
für KLS-Martin- und Berchtold-Geräte

Connection cable for bipolar instruments,
for KLS Martin and Berchtold units

Cable de conexión para instrumentos
bipolares para aparatos KLS Martin y Berchtold

Câble de raccordement pour instruments
bipolaires pour appareils KLS Martin et
Berchtold

Cavo di connessione per strumenti bipolari per
apparecchi KLS Martin e Berchtold

Nummern-Index

Index of order numbers

Índice de números de referencia

Index numérique des références de commande

Elenco dei codici

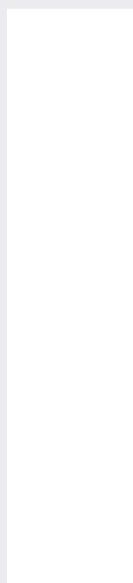
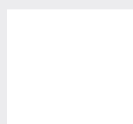

Nummern-Index

Index of order numbers

Índice de números de referencia

Index numérique des références de commande

Elenco dei codici

10

10-050-01	2
10-050-02	2
10-050-03	2
10-116-03	3
10-117-03	3
10-118-03	3
10-120-04	3
10-130-03	3
10-137-07	3
10-137-71	3
10-146-03	3
10-147-03	3
10-150-10	4
10-150-11	4
10-150-12	4
10-150-13	4
10-150-15	4
10-150-16	4
10-150-17	4
10-151-12	4
10-151-15	4
10-155-10	4
10-155-11	4
10-155-12	4
10-155-13	4
10-155-15	4
10-155-16	4
10-155-17	4
10-156-12	4
10-156-15	4
10-159-00	5
10-160-01	5
10-160-61	5
10-160-62	5
10-160-63	5
10-160-64	5
10-160-65	5
10-160-66	5
10-160-67	5
10-160-68	5
10-160-69	5
10-295-10	6
10-295-11	6
10-295-12	6
10-295-13	6
10-295-15	6
10-296-12	6
10-296-15	6
10-875-00	325

11

11-100-14	8
11-102-14	8
11-104-14	8
11-105-14	8
11-107-14	8
11-109-14	8
11-120-14	9
11-122-14	9
11-124-14	9
11-125-14	9
11-127-14	9
11-129-14	9
11-226-16	10
11-227-16	10
11-248-11	10
11-249-11	10
11-250-14	10
11-252-14	10
11-254-14	10
11-255-14	10
11-257-14	10
11-259-14	10
11-264-15	11
11-265-15	11
11-280-18	11
11-284-18	11
11-285-18	11
11-298-14	12

11-299-14	12
11-300-15	12
11-301-15	12
11-324-16	13
11-325-16	13
11-326-14	13
11-327-14	13
11-328-14	13
11-329-14	13
11-330-18	14
11-331-18	14
11-335-18	14
11-339-12	14
11-339-18	14
11-340-14	15
11-341-14	15
11-344-11	15
11-345-11	15
11-350-14	15
11-351-14	15
11-358-13	16
11-379-45	16
11-459-17	16
11-495-17	16
11-497-17	16
11-566-13	17
11-567-13	17
11-570-12	17
11-571-12	17
11-584-12	17
11-587-12	17
11-589-12	17
11-593-11	18
11-594-11	18
11-595-11	18
11-605-16	18
11-607-16	18
11-618-08	18
11-619-08	18
11-620-09	19
11-620-10	19
11-621-09	19
11-621-10	19
11-622-10	19
11-624-09	19
11-625-09	19
11-630-11	20
11-631-11	20
11-633-11	20
11-635-11	20
11-640-12	20
11-641-12	20
11-680-11	20
11-681-11	20
11-682-11	20
11-683-11	20
11-710-15	22
11-710-18	22
11-710-19	22
11-710-21	22
11-710-23	22
11-711-15	22
11-711-18	22
11-711-19	22
11-711-20	22
11-711-21	22
11-711-23	22
11-712-15	22
11-712-18	22
11-712-19	22
11-712-21	22
11-712-23	22
11-713-15	22
11-713-18	22
11-713-19	22
11-713-20	22
11-713-21	22
11-713-23	22
11-714-18	23
11-715-18	23

11-716-15	22
11-716-18	22
11-716-21	22
11-717-15	22
11-717-18	22
11-717-21	22
11-718-15	22
11-718-18	22
11-718-21	22
11-719-15	22
11-719-18	22
11-719-21	22
11-765-18	23
11-767-18	23
11-769-18	23
11-819-13	20
11-824-09	21
11-826-13	21
11-830-14	21
11-830-18	21
11-834-14	21
11-840-12	21
11-865-12	394
11-874-10	394
11-875-10	394
11-878-12	394
11-879-12	394
11-883-14	24
11-883-18	24
11-885-16	24
11-902-14	24
11-903-14	25
11-904-14	24
11-905-14	25
11-906-14	24
11-907-14	25
11-914-14	25
11-914-18	25
11-915-14	25
11-915-17	25
11-936-11	26
11-937-11	26
11-938-14	26
11-939-14	26
11-942-18	26
11-943-18	26
11-948-14	26
11-949-14	26
11-954-14	27
11-955-14	27
11-956-14	27
11-957-14	27
11-960-18	27
11-961-18	27
11-962-18	27
11-962-20	27
11-965-14	28
11-965-17	28
11-965-20	28
11-965-23	28
11-980-13	29
11-981-13	29
11-982-11	29
11-983-11	29
11-989-11	29
11-991-12	29
11-992-16	30
11-993-16	30
11-994-17	30
11-995-12	394
11-996-16	394
11-997-16	30
11-999-16	30

12

12-100-14	32
12-100-16	32
12-100-18	32
12-120-14	32
12-120-16	32

12-120-18	32
12-166-12	32
12-168-12	32
12-168-15	32
12-172-12	33
12-172-15	33
12-174-17	33
12-184-18	33
12-236-15	34
12-246-12	34
12-246-15	34
12-270-15	34
12-276-18	34
12-278-18	34
12-279-18	34
12-301-14	35
12-301-16	35
12-301-18	35
12-321-14	35
12-321-16	35
12-368-15	35
12-370-15	35
12-372-12	35
12-372-15	35
12-400-12	36
12-402-12	36
12-403-12	36
12-404-12	36
12-404-15	36
12-406-12	36
12-406-15	36
12-560-18	37
12-561-18	37
12-562-18	37
12-563-18	37
12-564-15	37
12-564-18	37
12-565-15	37
12-565-18	37
12-566-15	37
12-566-18	37
12-566-21	37
12-566-23	37
12-567-15	37
12-567-18	37
12-567-21	37
12-567-23	37
12-568-15	38
12-568-18	38
12-569-15	38
12-569-18	38
12-570-15	38
12-570-18	38
12-570-21	38
12-570-23	38
12-571-15	38
12-571-18	38
12-571-21	38
12-571-23	38
12-574-15	38
12-574-18	38
12-574-21	38
12-574-23	38
12-576-15	38
12-576-18	38
12-576-21	38
12-576-23	38
12-578-15	37
12-578-18	37
12-579-15	37
12-579-18	37
12-580-15	37
12-580-18	37
12-580-21	37
12-581-15	37
12-581-18	37
12-581-21	37
12-582-15	38
12-582-18	38
12-583-15	38

12-583-18	38
12-584-15	38
12-584-18	38
12-584-21	38
12-585-15	38
12-585-18	38
12-585-21	38
12-586-15	38
12-586-18	38
12-586-21	38
12-588-15	38
12-588-18	38
12-588-21	38
12-589-15	38
12-589-18	38
12-589-21	38
12-590-15	38
12-590-18	38
12-590-21	38
12-720-13	42
12-721-13	42
12-725-11	42
12-740-15	42
12-741-15	42

13

13-176-14	44
13-176-16	44
13-310-12	44
13-310-14	44
13-311-14	44
13-312-12	44
13-312-14	44
13-313-12	44
13-313-14	44
13-316-18	45
13-317-18	45
13-318-18	45
13-319-18	45
13-320-10	45
13-320-12	45
13-321-10	45
13-321-12	45
13-322-10	45
13-322-12	45
13-323-10	45
13-323-12	45
13-326-15	46
13-327-15	46
13-328-15	46
13-329-15	46
13-330-14	46
13-331-14	46
13-364-18	46
13-365-18	46
13-374-13	47
13-374-14	47
13-374-16	47
13-375-13	47
13-375-14	47
13-375-16	47
13-384-13	47
13-384-14	47
13-385-13	47
13-385-14	47
13-385-16	47
13-419-18	47
13-875-09	48
13-881-05	48
13-881-09	48
13-915-08	48
13-915-11	48
13-915-13	48
13-915-15	48
13-916-15	48
13-923-10	48
13-923-13	48
13-923-14	49
13-924-11	49
13-924-14	49

15

15-068-01	52
15-068-02	52
15-072-01	52
15-072-02	52
15-074-01	52
15-074-02	52
15-074-03	52
15-074-04	52
15-075-01	52
15-075-02	52
15-075-03	52
15-075-04	52
15-091-10	53
15-091-12	53
15-091-14	53
15-091-16	53
15-091-18	53
15-095-10	53
15-095-17	53
15-095-20	53
15-095-22	53
15-161-01	53
15-161-02	53
15-291-01	57
15-291-02	57
15-291-03	57
15-291-04	57
15-291-05	57
15-293-01	57
15-293-02	57
15-293-03	57
15-293-04	57
15-293-05	57
15-317-01	54
15-317-02	54
15-317-03	54
15-317-04	54
15-317-05	54
15-317-06	54
15-317-07	54
15-317-08	54
15-317-09	54
15-325-01	55
15-351-01	55
15-351-02	55
15-351-03	55
15-361-01	55
15-361-02	55
15-361-03	55
15-561-01	58
15-561-02	58
15-561-03	58
15-655-00	56
15-655-01	56
15-655-02	56
15-655-03	56
15-663-00	56
15-665-00	56
15-667-06	56
15-669-13	56

16

16-100-11	64
16-100-13	64
16-100-14	64
16-100-16	64
16-100-18	64
16-100-20	64
16-100-25	64
16-100-30	64
16-102-11	64
16-102-13	64
16-102-14	64
16-102-16	64
16-102-18	64
16-102-20	64
16-103-13	64
16-103-14	64
16-103-16	64

16-103-18	64
16-103-20	64
16-103-25	64
16-420-12	64
16-420-14	64
16-420-16	64

17

17-407-01	66
17-409-01	66
17-416-01	66
17-418-15	67
17-418-20	67
17-418-30	67
17-418-50	67
17-422-15	67
17-610-00	68
17-610-01	68
17-625-50	68
17-627-75	68
17-640-01	69
17-640-02	69
17-645-15	69
17-645-20	69
17-645-25	69
17-645-30	69

18

18-501-14	94, 149
18-501-18	94, 149
18-502-14	94, 149
18-502-18	94, 149
18-503-14	94, 149
18-503-18	94, 149
18-504-14	94, 149
18-504-18	94, 149
18-506-14	94, 149
18-506-18	94, 149
18-523-06	95
18-523-07	95
18-523-08	95
18-523-09	95
18-523-10	95
18-523-11	95
18-523-12	95
18-523-13	95
18-529-30	95
18-529-35	95
18-529-45	95
18-575-05	96
18-575-06	96
18-575-07	96
18-575-08	96
18-575-24	96
18-579-23	96

20

20-002-15	98
20-002-18	98
20-003-15	98
20-003-18	98
20-004-15	98
20-004-18	98
20-005-15	98
20-005-18	98
20-010-15	98
20-010-18	98
20-010-21	98
20-010-23	98
20-011-15	98
20-011-18	98
20-011-21	98
20-011-23	98
20-012-15	98
20-012-18	98
20-012-21	98
20-012-23	98
20-013-15	98
20-013-18	98

20-013-21	98
20-013-23	98
20-016-15	98
20-016-18	98
20-017-15	98
20-017-18	98
20-018-15	98
20-018-18	98
20-019-15	98
20-019-18	98
20-020-15	98
20-020-18	98
20-020-21	98
20-021-15	98
20-021-18	98
20-021-21	98
20-022-15	98
20-022-18	98
20-022-21	98
20-023-15	98
20-023-18	98
20-023-21	98
20-100-18	99
20-101-18	99
20-102-18	99
20-103-18	99
20-316-13	100
20-317-12	100
20-334-13	101
20-336-13	101
20-348-15	101
20-350-15	101
20-390-14	101
20-390-16	101
20-390-18	101
20-390-20	101
20-396-16	102
20-396-18	102
20-500-15	102
20-516-14	102
20-516-17	102
20-516-20	102
20-526-14	102
20-526-17	102
20-574-18	103
20-576-20	103
20-604-13	103
20-604-15	103
20-605-15	99
20-605-18	99
20-605-21	99
20-605-23	99
20-606-15	99
20-606-18	99
20-606-21	99
20-606-23	99
20-607-15	99
20-607-18	99
20-607-21	99
20-607-23	99
20-608-15	99
20-608-18	99
20-608-21	99
20-608-23	99
20-612-18	100
20-612-21	100
20-620-00	104
20-620-01	104
20-620-14	104
20-620-18	104
20-620-21	104
20-621-14	104
20-621-18	104
20-621-21	104
20-624-13	104
20-632-12	104
20-634-13	104
20-634-14	104
20-636-13	105
20-637-12	105

20-637-13	105
20-638-15	105
20-638-20	105
20-642-16	105
20-642-18	105
20-642-20	105
20-646-18	106
20-646-20	106
20-672-14	106
20-672-18	106
20-673-12	106
20-673-15	106
20-673-16	106
20-674-14	107
20-674-17	107
20-674-20	107
20-676-14	107
20-676-17	107
20-676-20	107
20-678-17	107
20-678-20	107
20-678-23	107
20-684-18	107
20-686-20	108
20-692-18	108
20-692-20	108
20-692-23	108
20-696-20	108
20-696-23	108

21

21-165-14	21
21-165-18	21
21-165-20	21

22

22-500-01	395
22-500-15	395
22-501-15	395
22-502-18	395
22-511-01	396
22-516-18	396
22-523-16	398
22-524-15	398
22-526-18	398

23

23-060-20	110
23-060-30	110
23-060-40	110
23-061-20	110
23-061-30	110
23-061-40	110
23-105-02	110
23-105-03	110
23-105-04	110
23-105-05	110
23-105-06	110
23-106-02	110
23-106-03	110
23-106-04	110
23-106-05	110
23-106-06	110
23-109-02	111
23-109-03	111
23-109-04	111
23-109-05	111
23-109-06	111
23-110-02	111
23-110-03	111
23-110-04	111
23-110-05	111
23-110-06	111
23-132-04	111
23-132-06	111
23-132-08	111
23-132-10	111
23-132-12	111
23-133-04	111
23-133-06	111

23-133-08	111
23-133-10	111
23-133-12	111
23-136-02	112
23-136-03	112
23-136-04	112
23-136-06	112
23-136-08	112
23-136-10	112
23-136-12	112
23-136-15	112
23-136-53	112
23-136-54	112
23-136-56	112
23-136-58	112
23-136-60	112
23-136-62	112
23-136-65	112
23-198-02	113
23-198-03	113
23-198-04	113
23-198-05	113
23-198-06	113
23-198-08	113
23-198-10	113
23-216-01	114
23-220-17	114
23-221-00	114
23-262-19	114
23-262-90	114
23-264-19	114
23-280-10	115
23-280-20	115
23-280-30	115
23-280-40	115
23-304-10	115
23-304-20	115
23-304-30	115
23-304-40	115
23-308-10	115
23-308-20	115
23-308-30	115
23-308-40	115
23-320-01	119
23-358-00	116
23-358-01	116
23-358-12	116
23-359-00	116
23-359-10	116
23-359-11	116
23-360-00	117
23-360-01	117
23-360-02	117
23-360-03	117
23-360-04	117
23-360-05	117
23-360-06	117
23-360-07	117
23-360-11	116
23-360-22	116
23-360-33	116
23-360-44	116
23-362-00	118
23-362-11	118
23-362-22	118
23-362-33	118
23-364-00	118
23-364-01	118
23-364-02	118
23-364-03	118
23-364-04	118
23-383-03	119
23-383-04	119
23-395-21	119
23-400-18	123
23-402-18	121
23-435-17	120
23-435-19	120
23-436-04	120
23-436-05	120

Nummern-Index

Index of order numbers

Índice de números de referencia

Index numérique des références de commande

Elenco dei codici

23-436-07	120
23-436-16	120
23-436-22	121
23-436-23	121
23-446-18	121
23-448-01	122
23-448-02	122
23-448-11	123
23-449-18	124
23-452-09	124
23-452-51	125
23-452-54	125
23-454-19	125
23-454-20	125
23-490-01	126
23-490-02	126
23-490-03	126
23-490-04	126
23-490-05	126
23-491-01	126
23-491-02	126
23-491-03	126
23-491-04	126
23-492-01	127
23-493-01	127
23-500-02	166
23-510-17	127
23-513-16	127
23-799-12	128
23-801-14	128
23-805-14	128
23-807-17	128
23-819-18	128
23-835-30	128
23-836-00	128
23-836-30	128
23-836-90	129
23-864-15	129
23-865-15	129
23-876-15	129
23-877-15	129
23-879-18	129
23-883-17	129
23-887-18	129
23-939-17	130
23-941-15	130
23-944-15	130
23-946-15	130
23-947-16	130

24

24-384-16	39
24-386-16	39
24-388-16	39
24-389-16	39
24-390-16	39
24-438-12	49
24-439-12	49

25

25-040-40	198
25-402-99	180, 185, 191, 199, 203
25-420-16	193
25-422-10	180, 198, 203
25-422-15	180, 185, 191, 203
25-422-20	191, 203
25-423-10	180, 203
25-423-15	180, 185, 191, 203
25-423-20	191, 203
25-428-98	180, 203
25-429-98	180, 203
25-430-98	185, 191, 203
25-431-98	185, 191
25-432-16	180, 185, 191

25-432-98	185, 191
25-434-98	191, 203
25-435-10	181
25-435-15	187, 192
25-449-05	190
25-449-05-91	190
25-449-07	190
25-449-07-91	190
25-449-16	190
25-449-16-91	190
25-450-05	190
25-450-05-91	190
25-450-07	190
25-450-07-91	190
25-450-16	190, 199, 203
25-450-16-91	190, 199, 203
25-451-00	184, 190
25-451-00-91	184, 190
25-451-05	184, 190
25-451-05-91	184, 190
25-451-07	184, 190
25-451-07-91	184, 190
25-451-15	203
25-451-15-91	199, 203
25-452-00	184, 190
25-452-05	184, 190
25-452-05-91	184, 190
25-452-07	184, 190
25-452-07-91	184, 190
25-453-03	180
25-453-03-91	180
25-453-05	180, 203
25-453-05-91	180, 203
25-453-07	180
25-453-07-91	180
25-454-03	180
25-454-03-91	180
25-454-05	180
25-454-05-91	180
25-454-07	180
25-454-07-91	180
25-455-05	180
25-455-05-91	180, 198
25-455-07-91	180
25-457-05	180
25-457-05-91	180
25-457-07-91	180
25-480-99180	185, 191
25-483-13	185, 191, 199, 203
25-483-97	185, 191, 199, 203
25-484-97	191, 203
25-486-13	181, 187, 193
25-490-11	181, 187
25-492-98	180
25-493-98	180
25-494-13	180
25-540-13	191
25-540-97	191
25-540-98	191
25-542-17	191
25-601-05	200
25-601-07	200
25-601-09	200
25-601-11	200
25-601-13	200
25-650-01	180
25-651-01	180, 184
25-660-02	200
25-660-03	198, 200
25-660-04	180, 200
25-660-05	180, 200
25-660-06	180, 200
25-660-07	200
25-660-09	200
25-660-11	200

25-660-13	200
25-661-03	200
25-661-05	180, 200
25-662-04	201
25-662-04-72	201
25-662-04-75	201
25-662-05	189, 201
25-662-05-72	201
25-662-05-75	201
25-662-06	189
25-662-07	189, 201
25-662-07-72	201
25-662-07-75	201
25-662-09	201
25-662-09-72	201
25-662-09-75	201
25-662-11	201
25-662-11-72	201
25-662-11-75	201
25-662-13	201
25-662-13-72	201
25-662-13-75	201
25-662-15	201
25-662-15-72	201
25-662-15-75	201
25-662-17	201
25-662-17-72	201
25-662-17-75	201
25-662-19	201
25-662-19-72	201
25-662-19-75	201
25-662-34	201
25-662-35	201
25-662-37	201
25-662-39	201
25-662-41	201
25-662-43	201
25-662-45	201
25-662-47	201
25-662-49	201
25-663-37	201
25-663-39	201
25-663-45	201
25-663-47-75	201
25-663-47	189, 201
25-663-49	201
25-663-49-75	201
25-665-03	200
25-665-03-72	200
25-665-03-75	200
25-665-04	184, 189, 200
25-665-04-72	200
25-665-04-75	200
25-665-05	184, 189, 200
25-665-05-72	200
25-665-05-75	200
25-665-06	184, 189, 200
25-665-06-72	200
25-665-06-75	200
25-665-07	184, 189, 200
25-665-07-72	200
25-665-07-75	200
25-665-08	200
25-665-08-72	200
25-665-08-75	200
25-665-09	200
25-665-09-72	200
25-665-09-75	200
25-665-11	200
25-665-11-72	200
25-665-11-75	200
25-665-13	200
25-665-13-72	200
25-665-13-75	200
25-665-15	200
25-665-15-72	200

25-665-15-75	200
25-666-03-72	200
25-666-03-75	200
25-666-05	184, 189, 200
25-666-05-72	200
25-666-05-75	200
25-666-07	184, 189, 200
25-666-07-72	200
25-666-07-75	200
25-668-04	184, 189, 200
25-668-04-72	200
25-668-04-75	200
25-668-05	184, 189, 200
25-668-05-72	200
25-668-05-75	200
25-668-06	184, 189, 200
25-668-06-72	200
25-668-06-75	200
25-668-07	200
25-668-07-72	200
25-668-07-75	189, 201
25-669-05	189, 201
25-669-05-72	201
25-669-05-75	201
25-669-07	189, 201
25-669-07-72	201
25-669-07-75	201
25-670-02	200
25-670-03	200
25-670-04	180, 200
25-670-05	180, 200
25-670-06	180, 200
25-670-07	200
25-670-09	200
25-670-11	200
25-670-13	200
25-671-03	200
25-671-05	180, 200
25-672-04	201
25-672-04-72	201
25-672-04-75	201
25-672-05	189, 201
25-672-05-72	201
25-672-05-75	201
25-672-06	189, 201
25-672-07	189, 201
25-672-07-72	201
25-672-07-75	201
25-672-09	201
25-672-09-72	201
25-672-09-75	201
25-672-11	201
25-672-11-72	201
25-672-11-75	201
25-672-13	201
25-672-13-72	201
25-672-13-75	201
25-672-15	201
25-672-15-72	201
25-672-15-75	201
25-672-17	201
25-672-17-72	201
25-672-17-75	201
25-672-19	201
25-672-19-72	201
25-672-19-75	201
25-672-34	201
25-672-35	201
25-672-36	201
25-672-37	201
25-672-39	201
25-672-41	201
25-672-43	201
25-672-45	201
25-672-47	201

25-672-49	201
25-673-37	201
25-673-39	201
25-673-45	201
25-673-47	189, 201
25-673-47-75	201
25-673-49	201
25-673-49-75	201
25-675-03	200
25-675-03-72	200
25-675-03-75	200
25-675-04	184, 189, 200
25-675-04-72	200
25-675-04-75	200
25-675-05	184, 189, 200
25-675-05-72	200
25-675-05-75	200
25-675-06	184, 189, 200
25-675-06-72	200
25-675-06-75	200
25-675-07	184, 189, 200
25-675-07-72	200
25-675-07-75	200
25-675-08	200
25-675-08-72	200
25-675-08-75	200
25-675-09	199, 200
25-675-09-72	200
25-675-09-75	200
25-675-11	199, 200
25-675-11-72	200
25-675-11-75	200
25-675-13	200
25-675-13-72	200
25-675-13-75	200
25-675-15	200
25-675-15-72	200
25-675-15-75	200
25-676-03	200
25-676-03-72	200
25-676-03-75	200
25-676-05	184, 189, 200
25-676-05-72	200
25-676-05-75	200
25-676-07	184, 189, 200
25-676-07-72	200
25-676-07-75	200
25-678-04	184, 189, 200
25-678-04-72	200
25-678-04-75	200
25-678-05	184, 189, 200
25-678-05-72	200
25-678-05-75	200
25-678-06	184, 189, 200
25-678-06-72	200
25-678-06-75	200
25-678-07	200
25-678-07-72	200
25-678-07-75	200
25-679-05	189, 201
25-679-05-72	201
25-679-05-75	201
25-679-07	189, 201
25-679-07-72	201
25-679-07-75	201

28

28-203-15	136
28-207-18	136
28-209-18	136

Nummern-Index

Index of order numbers

Índice de números de referencia

Index numérique des références de commande

Elenco dei codici

Index

Index

Indice

Index

Indice

i

30

30-130-12	137
30-132-15	137
30-134-15	137
30-134-19	137
30-134-25	137
30-136-16	137
30-136-20	137
30-190-16	137
30-192-16	138
30-196-16	138

35

35-133-06	70
35-133-07	70
35-133-09	70
35-134-09	70
35-134-18	70
35-224-00	140
35-224-01	140
35-224-12	140
35-224-23	140
35-224-34	140
35-224-45	140
35-224-56	140
35-224-78	140
35-226-00	140
35-226-01	140
35-226-12	140
35-226-23	140
35-226-34	140
35-226-45	140
35-226-56	140
35-226-78	140

37

37-684-15	136
-----------	-----

38

38-010-01	170
38-010-02	170
38-010-03	170
38-010-04	170
38-010-05	170
38-011-16	131
38-014-00	131
38-017-01	142
38-017-02	142
38-017-03	143
38-017-04	143
38-017-05	143
38-018-01	150
38-019-01	150
38-020-01	148
38-020-02	148
38-020-03	148
38-020-04	148
38-025-00	149
38-025-01	149
38-030-03	151
38-030-05	151
38-030-08	151
38-030-10	151
38-030-18	142
38-032-03	151
38-032-05	151
38-032-08	151
38-032-10	151
38-033-01	152
38-033-02	152
38-033-03	152
38-033-04	152
38-034-01	152
38-034-02	152
38-034-03	152
38-034-04	152
38-040-02	153
38-040-04	153
38-040-06	153
38-040-08	153

38-050-01	121
38-050-02	121
38-050-03	346
38-050-04	346
38-050-45	154
38-050-65	154
38-050-80	154
38-051-45	154, 184, 190
38-103-01	154
38-111-02	154
38-120-10	154
38-127-02	154
38-130-50	155
38-130-52	155
38-130-54	155
38-130-58	155
38-130-90	155
38-140-13	155
38-150-11	155
38-161-11	156
38-161-14	156
38-161-92	156
38-161-93	156
38-171-12	156
38-179-16	156
38-179-20	156
38-240-00	157
38-240-01	157
38-240-02	157
38-240-03	157
38-240-13	157
38-243-11	158
38-246-14	158
38-249-14	158
38-251-12	158
38-261-13	158
38-263-15	158
38-265-00	158
38-271-15	159
38-277-14	159
38-281-14	159
38-297-01	159
38-297-02	159
38-350-16	160
38-352-15	160
38-363-18	160
38-375-13	160
38-375-16	160
38-385-19	160
38-403-01	161
38-403-02	161
38-403-03	161
38-403-11	162
38-403-12	162
38-403-13	162
38-452-17	163
38-467-17	163
38-468-02	163
38-525-01	146
38-525-02	147
38-526-0	146
38-526-02	147
38-527-01	144
38-527-02	144
38-607-22	163
38-796-04	164
38-796-06	164
38-796-08	164
38-797-04	164
38-797-06	164
38-799-06	164
38-799-08	164
38-800-04	165
38-800-05	110
38-881-07	164
38-881-10	164
38-883-07	165
38-883-11	165
38-883-15	165

39

39-311-19	226
39-311-20	226
39-313-17	226
39-781-08	286
39-781-10	286
39-781-12	286
39-781-14	286
39-781-16	286
39-781-18	286
39-781-20	286
39-781-22	286
39-781-24	286
39-781-26	286
39-781-28	286
39-781-30	286

40

40-001-00	228
40-002-00	228
40-004-00	232
40-007-00	228
40-013-00	232
40-017-00	228
40-018-00	228
40-018-01	229
40-022-00	232
40-023-00	232
40-024-00	232
40-029-00	229
40-033-00	233
40-033-01	233
40-033-03	233
40-033-06	233
40-034-00	229
40-035-00	229
40-036-00	234
40-046-00	234
40-046-01	234
40-046-02	234
40-049-00	229
40-051-00	230
40-051-01	230
40-051-03	230
40-067-00	230
40-067-01	230
40-067-02	230
40-073-00	235
40-074-00	235
40-074-06	235
40-074-07	235
40-075-00	235
40-076-00	231
40-076-07	231
40-079-00	236
40-079-01	236
40-079-02	236
40-086-01	236
40-086-02	236
40-086-03	237
40-097-00	231
40-133-00	237
40-146-00	237
40-151-00	231
40-153-00	231
40-233-00	237
40-301-00	238
40-302-00	238
40-307-00	238
40-313-00	240
40-317-00	238
40-318-00	238
40-322-00	240
40-330-00	239
40-333-00	240
40-351-00	239
40-351-01	239
40-367-01	239
40-373-00	241
40-374-00	241

40-374-01	241
40-379-00	241
40-401-00	250
40-407-00	250
40-413-00	252
40-417-00	250
40-418-00	250
40-422-00	252
40-433-00	252
40-446-00	253
40-449-00	251
40-451-00	251
40-451-01	251
40-467-01	251
40-474-00	253
40-479-00	253
40-497-00	251
40-613-09	246
40-622-09	246
40-630-09	242
40-633-09	246
40-637-00	242
40-638-00	246
40-639-00	243
40-639-01	243
40-639-05	243
40-639-08	243
40-640-00	247
40-651-09	244
40-676-09	244
40-703-00	244
40-705-00	247
40-706-00	247
40-707-00	247
40-737-00	245
40-739-00	245
40-751-09	245
40-817-09	248
40-823-09	249
40-850-09	248
40-851-09	249

41

41-001-00	254
41-001-01	254
41-010-09	254
41-015-00	259
41-016-00	259
41-016-09	259
41-017-00	259
41-018-05	254
41-018-08	254
41-023-00	259
41-032-00	255
41-032-01	255
41-053-05	255
41-053-08	255
41-062-00	255
41-065-00	256
41-069-00	256
41-088-05	256
41-088-08	256
41-150-00	257
41-150-01	257
41-150-02	257
41-150-08	258
41-150-09	258
41-151-00	260
41-151-01	260
41-151-02	260
41-151-08	260, 263
41-151-09	260
41-222-00	261
41-500-00	262
41-500-01	262
41-500-02	262
41-500-03	262
41-500-04	262
41-500-06	263
41-500-07	263

41-500-08	263
41-501-00	258
41-502-00	261

42

42-001-05	266
42-001-08	266
42-002-00	266
42-003-00	266
42-003-01	266
42-004-05	266
42-004-08	266
42-006-00	266
42-008-00	266
42-009-00	266
42-010-00	266
42-011-00	266
42-012-00	267
42-027-00	267
42-028-00	267
42-034-00	267
42-034-09	267
42-039-00	267
42-040-00	267
42-046-00	267
42-050-00	267
42-051-00	267
42-200-01	267
42-200-03	267
42-204-00	268
42-204-01	268
42-204-02	268
42-205-00	268
42-205-01	268
42-220-01	269
42-220-02	269
42-220-03	269
42-220-04	269
42-221-01	269
42-221-02	269
42-221-03	269
42-221-04	269
42-222-01	270
42-222-02	270
42-222-03	270
42-222-04	270
42-223-01	270
42-223-02	270
42-223-03	270
42-223-04	270
42-301-00	271
42-302-00	271
42-303-00	271
42-304-00	271
42-311-00	271
42-405-01	271
42-405-02	271
42-405-03	271
42-415-01	271
42-415-02	271
42-415-03	271
42-505-01	271
42-505-02	271
42-505-03	271
42-508-01	272
42-508-02	272
42-508-03	272
42-508-04	272
42-511-00	272
42-511-01	272
42-511-02	272
42-512-00	272
42-512-01	272
42-512-02	272
42-513-00	273
42-513-01	273
42-513-02	273
42-514-00	273
42-514-01	273
42-514-02	273

Nummern-Index

Index of order numbers

Índice de números de referencia

Index numérique des références de commande

Elenco dei codici

42-515-00273	42-705-22287	43-321-06297	43-356-10326	43-493-02340
42-515-01273	42-706-22288	43-321-23297	43-356-11326	43-493-26340
42-515-02273	42-706-24288	43-323-32298	43-357-00326	43-493-27340
42-533-20274	42-707-22288	43-323-33298	43-358-12300	43-493-28340
42-533-21274	42-707-24288	43-323-35298	43-363-01303	43-493-29340
42-533-22274	42-710-03289	43-326-31299	43-364-01319	43-493-52340
42-533-23274	42-710-05289	43-326-32299	43-365-01165	43-493-54340
42-533-70274	42-710-06289	43-326-33299	43-365-02165	43-493-64340
42-533-71274	42-711-03289	43-326-34299	43-365-03304	43-493-66340
42-551-05275	42-711-05289	43-326-35299	43-365-04304	43-493-78340
42-551-08275	42-715-00290	43-326-36299	43-366-01304	43-493-80340
42-553-05275	42-715-01290	43-326-37345	43-366-02304	43-494-02341
42-553-08275	42-721-01290	43-326-38345	43-366-03304	43-494-04341
42-554-05275	42-721-02290	42-721-01290	43-400-02331	43-494-06341
42-554-08275	42-723-01290	42-726-02290	43-400-03332	43-500-31342
42-561-01275	42-726-02290	42-728-02290	43-400-06332	43-500-51342
42-567-01276	42-728-02290	42-746-02290	43-400-08332	43-504-01342
42-567-02276	42-755-02290	42-757-08290	43-400-09332	43-505-03343
42-571-01276	42-757-08290		43-400-12332	43-505-04343
42-571-02276			43-400-17332	43-505-05343
42-575-00276			43-400-23332	43-505-06343
42-575-02276			43-400-30332	43-505-09343
42-576-01277			43-400-60332	43-505-10343
42-576-02277			43-401-12332	43-505-12343
42-576-03277			43-402-03333	43-506-01344
42-577-01277			43-402-06333	43-506-02344
42-577-02277			43-402-08333	43-506-03344
42-577-03277			43-402-09333	43-507-02344
42-582-01277			43-402-11333	43-507-03344
42-582-02277			43-402-12333	43-507-04344
42-582-03277			43-402-17334	43-507-05344
42-584-01278			43-402-23334	43-507-06344
42-584-02278			43-402-33334	43-600-00167
42-584-03278			43-402-54334	43-600-01167
42-587-01278			43-402-66334	43-600-02167
42-587-02278			43-403-01335	43-600-03167
42-587-03278			43-403-02335	43-600-04167
42-602-00280			43-403-03335	43-600-05167
42-602-01280			43-403-04335	43-601-00168
42-602-04280			43-403-06335	43-601-01168
42-602-05280			43-403-16335	43-601-02168
42-604-00281			43-403-17335	43-601-03168
42-604-01281			43-403-23335	43-601-04168
42-604-02281			43-404-01336	43-601-05168
42-604-04281			43-404-02336	43-610-01174
42-606-00282			43-404-05336	43-610-02174
42-606-01282			43-404-23336	43-700-01132
42-606-02282			43-482-01337	43-700-02132
42-606-04282			43-482-02337	43-700-03132
42-608-00282			43-484-00337	43-711-08336
42-608-01282			43-484-01337	43-711-09336
42-625-01283			43-484-02337	43-711-10336
42-625-02283			43-484-03337	43-711-23336
42-625-12283			43-484-04337	43-734-11327
42-625-14283			43-486-34337	43-734-13327
42-625-16283			43-487-00338	43-734-21327
42-625-18283			43-487-02338	43-734-23327
42-625-20283			43-487-04338	43-735-11327
42-630-01283			43-487-06338	43-735-13327
42-630-02283			43-487-08338	43-735-21327
42-630-05283			43-487-10338	43-735-23327
42-630-10283			43-487-12338	43-736-00328
42-630-20283			43-487-14338	43-736-01328
42-630-50283			43-487-16338	43-736-04328
42-632-01283			43-487-18338	43-736-06328
42-632-02283			43-487-20338	43-736-08328
42-632-05283			43-487-22338	43-736-10328
42-632-10283			43-487-24339	43-736-11328
42-632-20283			43-487-26339	43-736-12328
42-632-50283			43-487-28339	43-736-15328
42-652-00284			43-487-30339	43-736-22328
42-652-01284			43-487-32339	43-736-26328
42-702-22287			43-487-34339	43-738-02329
42-702-24287			43-487-35339	43-738-04329
42-703-22287			43-487-36339	43-738-06329
42-703-24287			43-487-38339	43-738-08329
42-704-10287			43-487-40339	43-738-10329
42-704-18287			43-487-42339	43-738-12329
42-704-22287			43-487-44339	43-738-14329
42-704-24287			43-493-01340	43-738-16329

43

Nummern-Index

Index of order numbers

Índice de números de referencia

Index numérique des références de commande

Elenco dei codici

Index

Index

Indice

Index

Indice

i

43-738-18	329
43-738-20	329
43-738-22	330
43-738-24	330
43-738-26	330
43-738-28	330
43-738-30	330
43-784-02	305
43-784-18	295
43-800-00	307
43-800-01	307
43-800-02	307
43-80-02	169
43-80-03	169
43-805-01	169
43-806-01	169
43-806-02	169
43-806-03	169
43-810-00	302
43-810-01	302
43-840-00	324
43-840-01	324
43-840-02	324
43-840-05	324
43-840-06	324
43-840-08	324
43-840-09	325
43-883-16	133
43-884-03	133
43-885-03	133
43-893-01	301
43-893-02	301
43-893-06	301
43-893-08	301
43-894-01	166
43-896-00	171
43-896-01	171
43-896-02	171
43-896-03	171
43-897-00	172
43-897-01	172
43-897-02	172
43-897-03	172
43-899-01	173
43-899-02	173
43-899-03	173
43-899-04	173
43-899-11	173
43-899-22	173
43-899-33	173
43-899-44	173
43-900-01	170
43-900-02	170
43-900-03	170
43-900-04	170
43-900-05	170
43-910-01	170
43-910-02	170
43-910-03	170
43-910-04	170
43-910-05	170

44

44-185-01	350
44-187-01	350
44-187-05	350
44-200-30	350
44-200-31	350
44-269-03	351
44-269-04	351
44-272-03	351
44-272-04	351
44-330-01	352
44-330-02	352
44-330-03	352
44-330-04	352
44-330-05	352
44-330-10	352
44-332-01	352
44-332-02	352

44-332-03	353
44-332-04	353
44-332-05	353
44-332-06	353
44-334-01	353
44-334-02	353
44-334-03	353
44-334-04	353
44-370-00	354
44-370-02	354
44-370-04	354
44-370-06	354
44-370-08	354
44-370-10	354
44-375-00	355
44-375-01	355
44-375-02	355
44-377-01	356
44-377-02	356
44-377-03	356
44-377-04	356
44-377-05	356
44-377-18	356
44-377-27	356
44-377-28	356
44-377-29	356
44-379-01	357
44-379-02	357
44-379-03	357
44-379-11	357
44-379-12	357
44-379-13	357
44-380-02	358
44-380-04	358
44-380-06	358
44-380-08	358
44-380-10	358
44-380-12	358
44-380-14	358
44-380-16	358
44-380-18	358
44-380-20	358
44-380-22	358
44-380-24	358
44-380-26	358
44-380-28	359
44-380-30	359
44-380-32	359
44-380-34	359
44-380-36	359
44-380-38	359
44-380-40	359
44-380-42	359
44-380-44	359
44-380-46	359
44-380-48	359
44-380-50	359
44-380-52	359
44-382-01	360
44-382-02	360
44-382-03	360
44-384-01	361
44-384-02	361
44-384-03	361
44-386-02	361
44-386-03	361
44-388-01	361
44-388-02	361
44-390-01	362
44-390-02	362
44-390-03	362
44-390-11	362
44-390-12	362
44-390-13	362
44-390-21	362
44-390-22	362
44-390-31	362
44-390-32	362
44-392-01	363
44-392-02	363

44-392-03	363
44-392-10	363
44-392-11	363
44-392-12	363
44-392-13	363
44-394-07	364
44-394-19	364
44-394-77	364
44-396-06	364
44-396-11	364
44-396-79	364
44-398-01	365
44-398-02	365
44-398-04	365
44-399-11	365
44-399-12	365
44-399-13	365
44-432-03	366
44-438-01	366
44-438-02	366
44-438-03	366
44-438-14	366
44-442-00	366
44-442-01	366
44-444-01	367
44-444-02	367
44-444-03	367
44-445-01	367
44-465-01	368
44-467-01	368
44-468-01	368
44-470-01	368
44-470-02	368
44-470-03	368
44-470-04	368
44-470-05	368
44-470-06	368
44-480-05	368
44-480-06	368
44-480-07	368
44-481-01	369
44-481-05	369
44-482-01	369
44-482-13	369
44-484-07	369
44-484-08	369
44-484-09	369
44-484-10	369
44-484-11	369
44-484-12	369
44-484-13	369
44-485-05	369
44-485-06	369
44-485-07	369
44-500-16	370
44-502-15	370
44-503-17	370
44-506-16	370
44-513-17	370
44-515-26	371
44-515-27	371
44-515-28	371
44-515-29	371
44-515-30	371
44-515-31	371
44-515-51	371
44-515-60	371
44-520-00	371

46

46-101-00	374
46-101-01	374
46-101-02	374
46-101-03	374
46-101-04	374
46-102-01	374
46-102-02	374
46-102-03	374
46-103-01	374
46-103-02	374

46-103-03	374
46-104-01	374
46-104-02	374
46-104-03	374
46-106-00	375
46-106-01	375
46-106-02	375
46-106-03	375
46-106-04	375
46-107-01	375
46-107-02	375
46-107-03	375
46-108-01	375
46-108-02	375
46-108-03	375
46-131-00	375
46-131-01	375
46-131-02	375
46-131-03	375
46-131-04	375
46-132-01	376
46-132-02	376
46-132-03	376
46-133-01	376
46-133-02	376
46-133-03	376
46-134-01	376
46-134-02	376
46-134-03	376
46-136-00	376
46-136-01	376
46-136-02	376
46-136-03	376
46-136-04	376
46-137-01	377
46-137-02	377
46-137-03	377
46-138-01	377
46-138-02	377
46-138-03	377
46-151-01	378
46-151-02	378
46-151-03	378
46-152-11	378
46-152-12	378
46-152-13	378
46-161-01	378
46-161-02	378
46-161-03	378
46-162-11	378
46-162-12	378
46-162-13	378
46-171-01	378
46-172-11	378
46-175-01	378
46-176-11	378
46-181-01	379
46-182-11	379
46-185-02	380
46-280-17	380
46-288-17	380
46-320-13	381
46-321-13	381
46-342-01	382
46-342-02	382
46-342-03	382
46-342-04	382
46-342-05	382
46-342-90	382
46-361-02	383
46-362-01	383
46-362-02	383
46-362-03	383
46-363-01	384
46-363-02	384
46-363-03	384
46-364-01	384
46-364-02	384
46-365-01	384
46-365-02	384

46-365-03	384
46-366-01	384
46-366-02	384
46-366-03	384
46-367-01	385
46-367-02	385
46-368-01	385
46-368-03	385
46-369-08	385
46-373-18	385
46-374-00	386
46-374-05	386
46-374-06	386
46-374-07	386
46-374-92	386
46-374-99	386
46-392-02	387
46-394-02	387
46-401-02	387
46-462-02	387
46-470-01	388
46-470-02	389
46-480-15	390
46-481-17	390
46-482-13	390
46-482-17	390
46-517-15	390
46-518-15	390
46-520-01	390
46-528-01	390
46-530-01	390
46-546-01	390
46-578-02	390
46-582-01	391
46-583-00	391
46-583-01	391
46-583-02	391
46-583-03	391
46-593-00	391
46-595-13	392
46-596-00	392
46-597-00	392
46-599-13	392
46-655-00	392

47

47-102-21	406
47-114-21	406
47-120-27	406
47-505-14	396
47-518-14	396
47-521-13	396
47-522-13	396
47-524-14	397
47-538-15	397
47-540-13	397
47-554-11	397
47-555-11	397
47-556-11	397
47-562-12	399
47-563-11	399
47-572-11	399
47-580-01	399
47-582-11	400
47-582-13	400
47-583-01	400
47-584-01	400
47-585-01	401
47-585-02	401
47-585-03	401
47-586-01	401
47-604-13	402
47-606-13	402
47-608-13	402
47-650-12	403
47-654-13	403
47-660-13	403
47-672-11	403
47-674-13	403

Nummern-Index

Index of order numbers

Índice de números de referencia

Index numérique des références de commande

Elenco dei codici

47-690-15404
47-697-15404
47-702-15404
47-750-14405
47-751-14405
47-783-12405
47-788-13405
47-794-13405

48

48-101-1659
48-101-2559
48-101-3559
48-101-4259
48-101-5559
48-101-7059
48-101-8059
48-103-1660
48-103-2560
48-103-3560
48-103-4260
48-103-5560
48-103-7060
48-103-8060
48-125-1561
48-135-21134
48-137-21134

50

50-022-01220
50-541-00145
50-580-00145
50-700-00196, 197, 198
50-800-02218, 219
50-800-03218, 219
50-910-15145
50-910-20145
50-910-27145
50-915-15145
50-915-20145
50-915-27145

51

51-500-90186, 192
51-505-90186, 192
51-520-10183
51-520-15183
51-520-70183, 187
51-520-95186, 192
51-523-06178
51-523-09178
51-523-12178
51-524-06182
51-524-09182
51-524-12182
51-524-15182
51-525-06179
51-525-09179
51-525-12179
51-525-15179
51-525-76181, 187
51-525-80181, 187, 192
51-525-85181, 186
51-525-90181, 186
51-525-95181, 186
51-530-10188
51-530-15188
51-530-70193

52

52-301-28211, 215, 222
52-302-25215
52-303-25222
52-303-28222
52-303-50215, 222
52-303-52222
52-313-25222
52-313-50222
52-400-10218, 219

52-400-12218, 219
52-400-13218, 219
52-500-00216, 217
52-500-02216, 217
52-500-03216, 217
52-500-33216, 217
52-501-01216, 217
52-501-02216, 217
52-501-03215
52-501-04211, 215,
.....216, 217

52-502-01216, 217
52-504-00216, 217
52-509-05211, 215,
.....221
52-509-06211, 215,
.....221
52-510-03220
52-510-04220
52-510-05220
52-510-06220
52-510-07220
52-510-08220
52-515-05211, 213,
.....221
52-515-06211, 213,
.....221
52-515-1213,
.....221
52-515-20213,
.....221

52-516-03220
52-516-04220
52-516-05220
52-516-06220
52-516-08220
52-516-10220
52-516-24211, 215,
.....223
52-516-25211, 215,
.....223
52-516-26223
52-516-27223
52-516-51213, 220
52-516-52213, 221
52-516-54211, 215,
.....223
52-516-55211, 215,
.....223
52-516-56223
52-516-57223
52-516-60213, 220,
.....221

52-521-24211, 223
52-521-25211, 223
52-521-27223
52-521-29223
52-521-31213, 223
52-521-33213, 223
52-521-35213, 223
52-521-37213, 223
52-521-54211, 223
52-521-55211, 223
52-521-57223
52-521-59223
52-522-10213, 221
52-610-03221
52-610-04221
52-610-05221
52-610-08221
52-616-03221
52-616-04221
52-616-05221
52-616-10221

54

54-305-10408
54-336-14408
54-336-16408
54-347-13408

54-353-12408
54-378-10408
54-378-12408
54-379-10408
54-379-12408
54-386-10409
54-388-11409
54-389-16409
54-405-01409

55

55-004-02423
55-004-03423
55-004-04423
55-004-05423
55-004-06423
55-004-07423
55-005-01423
55-005-02423
55-006-01423
55-006-02423
55-006-03423
55-006-04423
55-007-01423
55-007-02423
55-008-01423
55-008-02423
55-008-03423
55-008-04423
55-008-10423
55-009-00216, 217
55-009-01422
55-009-02422
55-009-06423
55-015-10422
55-015-20422
55-015-30422
55-085-27412
55-091-30412
55-162-20412
55-164-20412
55-300-50413
55-300-65413
55-300-75413
55-302-50413
55-302-65413
55-302-75413
55-309-65413
55-310-65413
55-313-08413
55-322-13413
55-335-01414
55-335-02414
55-335-03414
55-335-05414
55-337-01414
55-337-02414
55-340-02414
55-348-00414
55-348-01414
55-358-25415
55-358-32415
55-395-12416
55-395-18416
55-395-25416
55-395-26416
55-398-00417
55-398-01417
55-398-99417
55-400-23418
55-400-26418
55-400-27418
55-400-30418
55-400-32418
55-400-42418
55-402-23418
55-402-26418
55-402-30418
55-402-32418

55-402-42418
55-409-23418
55-409-26418
55-409-28418
55-409-30418
55-409-32418
55-409-42418
55-669-58419
55-700-00199
55-808-20422
55-808-21422
55-861-40216, 217
55-861-40422
55-861-60422
55-864-01422
55-864-02422
55-864-03422
55-864-04422
55-864-05422
55-864-06422
55-864-10422
55-864-11422
55-864-12422
55-864-13422
55-864-14422
55-864-15422
55-864-16422
55-864-17422
55-864-18422
55-891-40423
55-962-07197
55-962-43218, 219
55-962-44218, 219
55-962-45218, 219
55-963-28197
55-963-38217
55-963-51218, 219
55-964-28197
55-964-30216, 217
55-969-42216, 217
55-969-44218, 219
55-969-46218, 219
55-969-70198, 199
55-969-93216, 217
55-996-54419
55-999-80419
55-999-89419

56

56-231-04426
56-231-06426
56-231-08426
56-231-11426
56-231-12426
56-231-14426
56-231-16426
56-231-18426
56-235-11426
56-235-12426
56-235-14426
56-235-16426
56-235-18426
56-240-11426
56-254-01426
56-256-02426
56-256-05426
56-256-10426
56-256-20426
56-280-10426
56-284-09426
56-285-10426
56-321-23427
56-321-30427
56-321-31427
56-321-35427
56-321-40427
56-324-21427
56-324-24427
56-324-30427
56-324-31427

56-324-35427
56-324-40427
56-324-42427
56-340-23427
56-348-22427
56-360-30428
56-360-50428
56-360-51428
56-360-52428
56-360-75428
56-360-76428
56-360-77428
56-360-98428
56-360-99428
56-365-50428
56-365-75428
56-365-99428
56-366-50428
56-366-75428
56-366-99428
56-411-16428
56-411-20428
56-411-21428
56-411-23428
56-411-26428
56-411-27428
56-411-30428
56-411-33428
56-412-16428
56-412-20428
56-412-21428
56-412-23428
56-412-26428
56-412-27428
56-412-30428
56-412-32428
56-412-33428
56-412-42428
56-412-43428
56-419-20429
56-430-06429
56-430-07429
56-431-06429
56-431-10429
56-432-08429
56-432-12429
56-435-15429
56-602-25429
56-604-50429
56-610-20429
56-620-75429
56-650-90430
56-654-75430
56-662-75430
56-669-75430
56-673-17430
56-673-25430
56-673-27430
56-675-25430
56-702-23431
56-702-31431
56-830-10431
56-860-01431
56-860-02431
56-868-01431
56-868-05431
56-960-09432
56-964-06432

57

57-101-01434
57-101-02434
57-101-03434
57-101-04434
57-101-10434
57-101-11434
57-101-15434
57-101-21435
57-101-22435
57-101-23435

57-101-30435
 57-110-01436
 57-110-02436
 57-110-03436
 57-110-04436
 57-110-10436
 57-110-11436
 57-110-15436
 57-110-22436
 57-110-23436
 57-110-30436
 57-120-05437
 57-120-07437
 57-120-09437
 57-120-13437
 57-120-15437
 57-125-05437
 57-130-05438
 57-130-07438
 57-150-07438
 57-160-01438
 57-160-02438
 57-160-03438
 57-160-04438
 57-201-01439
 57-201-02439
 57-210-01439

61

61-011-32440
 61-011-42440
 61-015-32440
 61-015-42440
 61-023-32441
 61-023-42441
 61-132-37441
 61-132-42441

73

73-301-03442
 73-303-03442
 73-304-07442
 73-306-08442
 73-306-12442
 73-306-13442
 73-306-15442
 73-308-20442
 73-308-25442
 73-308-30442
 73-315-00443
 73-315-13443
 73-315-15443
 73-318-30443
 73-318-50443
 73-370-95443
 73-454-15444
 73-455-15444
 73-470-58444
 73-474-55444

80

80-006-02448
 80-010-02458
 80-107-00448, 449
 80-108-00458
 80-214-11448, 449,
450
 80-217-01454, 455,
458, 459
 80-217-02460
 80-287-53462
 80-310-04450
 80-332-03454, 455,
458, 459, 460
 80-370-50454, 455,
458, 459, 460
 80-371-00460
 80-371-01454, 455,
458, 459, 460
 80-408-00454, 455,

.....458, 459, 460
 80-444-08448, 449,
450
 80-461-01448, 449,
451
 80-461-02448, 449,
451
 80-461-12448, 449,
451
 80-461-14448, 449,
451
 80-461-15448, 449,
451
 80-461-31448, 449,
451
 80-461-34448, 449,
451
 80-510-04454, 455,
458, 459, 461
 80-515-04454, 455,
458, 459, 461
 80-520-04454, 455,
458, 459, 461
 80-525-04454, 455,
458, 459, 461
 80-532-00454, 455,
458, 459, 461
 80-540-04454, 455,
458, 459, 461
 80-542-04454, 455,
458, 459, 461
 80-560-04454, 455,
458, 459, 461
 80-562-04454, 455,
458, 459, 461
 80-811-50461
 80-812-10450
 80-925-16462

86

86-010-1072
 86-010-2073
 86-013-1072
 86-013-2073
 86-031-0074
 86-031-1074
 86-031-2075

Index, alphabetisch

Deutsch

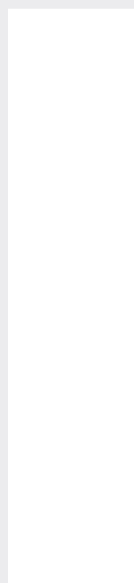
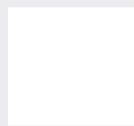

- A**
 Abdrucklöffel374-379
 Abdrucklöffel für partielle Abdrücke378,379
 Abell405
 Abfalleimer444
 Adams154,403
 Aderer400,403
 Adson32,34,35,46
 Adson-Brown36
 Ainsworth370
 Allen-Igthaut121,346
 Allis137
 Allis-Baby137
 Alveotomiefeilen127
 Amalgaminstrumente350
 Anatomische Pinzetten32,34
 Angle401,403
 Apical270,271
 Apical-Flohr271
 Arkansas324,325
 Arterienklemmen44,45,46,47,49
 Ash, Zahnfleischmesser2
 atraumatische Pinzetten34,33
 Auflagerungen – Onlay Grafts212,213
- B**
 Babcock137,138
 Backhaus48
 Beale387
 Becher430
 Beebee394
 Bein269,272,273
 Bereitschaftskästen418
 Bestell- und Set-Empfehlungen
 Sonic Weld Rx®216-219
 Beyer129
 Bishop158
 Black340
 Böhler129,130
 Bone Graft Kit196,203
 Bonn19
 Brewer370
 Briault333
 Brückenabnehmzangen404
 Brünings160
 Bruns115
 Buck21
 Buckley110
 Bügelbiegezangen399-402
- C**
 Castroviejo100,104
 Cawood-Minnesota158
 Cheattle412
 Chirurgische Küretten118,119
 Chirurgische Pinzetten34,35,36
 Chirurgische Scheren8,9,10,15,17,
18,24,25,26
 Chompret277
 Cleveland128,130
 Coleman271
 Collin163
 Columbia305
 Container420-423
 Coupland271
 Crane-Kaplan42,300
 Crile102
 Crile-Murray101
 Crile-Wood101,103,105
 Cross330
 Crown-Butler391
 Cryer266,267
 Cumine293
- D**
 Dean16,30
 DeBakey34,106
 DeBakey-Mosquito49
 Denhart156
 Derf104
 Desmarres53
 Diamant392
 Diamantierte Zahnzangen Martin Ergo,
 Oberkiefer250,251
 Diamantierte Zahnzangen Martin Ergo,
 Unterkiefer252,253
 Diethrich-Salyer16
 Dilatatore174
 Distraktoren178-193
 Doyen160
 Draht-, Bogen- und Klammernbiegezangen ...403
 Drahtknifzangen, Seitenschneider398
 Drahtscheren394
 Drahtwirbelzangen395
 Dumont397
 Durahaken136
- E**
 Ehricke374-377
 Einmalskalpelle6
 Eiselsberg21
 Elefantenußstopfer355
 Elektrochirurgie-Gerät MD 62446,447
 Elektrochirurgie-Gerät ME 102456,457
 Elektrochirurgie-Gerät Minicutter452,453
 Elevatorien127,131,133,134
 Elite-Abdrucklöffel
 nach Ehricke374-377
 Emons120
 Epker164
 Exkavatoren337-339
- F**
 Fadenscheren20,21
 Fadenstopfer380
 Fahnenstock390
 Farabeuf56
 Farrell64
 Felt352,353
 Fingerschutz154
 Flachmeißel110
 Flagg41
 Flohr267
 Foster-Gillies106
 Frahm384
 Fräser154
 Freer123
 Friedman271
 Friedmann128
 Füllungsinstrumente351,358-361,364,365
 Furrer404
- G**
 Gefäßpinzetten39
 Gesichtsschutz409
 Gewebefasszangen137,138
 Gilles34,35,136
 Gillies106
 Gillies-Mini106
 Gingivektomiemesser345-347
 Gisy-Wild390
 Goldman-Fox17,29,299,328
 Goldstein353
 Goslee397
 Gracey310-317,320-323
 Gracey Küretten mit 10 mm-Griff316,317
 Gracey Mini-Küretten,
 subgingivaler Einsatz310,311,320,321
 Gracey Rigid-Küretten,
 subgingivaler Einsatz314,315
 Gracey Standard-Küretten,
 subgingivaler Einsatz312,313,322,323
 Greenstein388,389
 Gregory100
 Gritmann390
 Guthrie52
- H**
 Halbstanze Weichgewebe170
 Half-Trays436
 Halsey101,105
 Halsted-Mosquito44,45
 Hämmer114,406
 Hartmann128,159
 Hauthäkchen52,136
 Hautscheren408
 Hegar-Baumgartner104
 Heidebrink277,278
 Heidemann365
 Heister155
 Hemingway116
 Henahan161,162
 Herbert114
 HF-Chirurgie446-462
 Hirschfeld300
 Hohlmeißel111
 Hohlmeißelzangen128,129
 Hollenback359,384
 How405
 Hygienist296
 Hylin272,387
- I**
 Igthaut23,37,99,110,119,121,132,
142,165,167-170,174,326
 Infektions-Schutzbrillen409
 Instrumentenkästen428,429
 Instrumententablets427
 Irisscheren19,20
 Ivory368,370
- J**
 Jaboma23,34,293,298
 Johnson405
 Jones48
 Joseph15,26,136
- K**
 Kahre-Williger120
 Kappenzangen415
 Kehlkopfspiegel286
 Kelly10,20,46
 Killner136
 Kinderzahnzangen, Amerikanische Form,
 Oberkiefer248,249
 Kinderzahnzangen, Englische Form,
 Oberkiefer242-245
 Kinderzahnzangen, Englische Form,
 Unterkiefer246,247
 Kinnhalter61
 Kirkland347
 Knochenfalle149
 Knochenfeilen126
 Knochenmühle150
 Knochenquetsche150
 Knochen splitterzangen130
 Knochenspreizer173
 Knochenspritzen153
 Knopfsonden64,140
 Kocher47,55
 Kocher-Langenbeck54
 Kofferdam-Instrumente370,371
 Kompositinstrument352-354
 Konturzangen405
 Kopflupe68
 Körner-Westermann122,123,142,143,
166,171,172
 Korund324
 Krallenheber276
 Kroneninstrumente390-392

Kronenzangen405
Kugel/Spatel-Kombination362
Kugelpfropf356
Küretten, subgingivaler Einsatz
.....305-307,318,319

L

Lagerungstray416,417
La-Grange18
Lambotte-Mini112
Langenbeck57,108,154
Langenbeck Mini53
Langer306
Le Cron387
Lecluse275
Leriche46
Lexer-Fino13
Lexer-Mini111
Lichtenberg103,108
Lichtenstein380
Lindemann154
Lindo-Levian267
Lindorf144-147
Lippen- und Wangenhalter157,158
Lister21
Littauer21
Locklin18,30
London-College40
Lucas-Martin118
Luer129
Luniatschek226
Luxatoren269,270

M

Martin41,42,160,367,394,395,415,444
Martin Erg-O-Norm434-439
Martin-ECO416
Martin-Proper413
Martin-Simplex158
Maßstäbe67
Mathieu102,107
Matrizen368,369
Matrizenspanner368,369
Maunder154
Mayfield129
Mayo-Hegar101,102,105
Mayo-Lexer24
McCall294,295,305
McKesson155
Mead114
Medizinbecher429
Mehrzweckschalen427
Meiss148
Meißel165
Meißel, Raspatorien132
Membranfixierung und Guided Bone
Regeneration210,211
Mercitan300
Mercury328,383
Meriam40
Merrit A328
Merrit E328
Mershon390
Messbecher426
Messzirkel70
Metall Dosen429
Metallschalen426
Metallschalen439
Metzenbaum10,11,12,24,26
Metzenbaum-Fino13,14,27,28
Metzenbaum-Lahey28
Metzenbaum-Nelson11
Michigan328
MicroStop® - Mini-Set-Container420-423
Middeldorp55
Mikro Adson36
Mikro Mosquito45
Mikro-Mundspiegel289

Mikro-Nadelhalter98,99,104
Mikropinzetten37,38
Mikroscheren22,23
Mikro-Skalpellklingen5
Miller127,390
Miller-Apexo266
Miller-Colburn118,126
Mini Adson32,36
Minimal invasive Sinus-Lift-Küretten148
Mini-Zementspatel366
Mitchell293
Mixer-Baby47
Molt124,125,156
Mundkeile154,155
Mundsperrer155,156
Mundspiegelansätze287,288
Mundspiegelgriffe290

N

Nabers326,327,336
Nadeldosen, Nadelkassetten,
Bereitstellungsbecher414
Nadeletuis412,413
Nadelhalter101,102,103,105,106,107,108
Nagelfeilen409
Nagelscheren, Nagelzangen408
Nervkanal-Instrumente342-344
Nierenschale430
Norm-Trays434,435
Northbent20
Nyström384

O

Obwegeser59,60,61,134,155,158,163
Ochsenbein133,165
Ohl124
Olsen Hegar106
Orban347
Oringer157
Osteosynthese194,195
Osteotome111,112,164,166-169,171,172

P

Paris390
Parodontalfeile301,302
Parodontalmeißel165,303,304
Parodontometer326-330
Partsch110,111
Peaen44,47
Peers- Bertram48,49
Peet42
Periotome116,117
Petrischalen426
Pitha154
Planstopfer357
Polierinstrumente356
Pott276
Präparierklemmen46,47
Präparierscheren11-16,18,24,26,28,
Prichard120,319

R

Ragnell29
Rahmen für Linsen69
Ralk42
Ramushaken163
Ramusosteotome164
Raspatorien120,125,127,133,134
Reinigungsbürsten442,443
Reynolds405
Rhodes303
Roncati302,307
Roncati Fine Kit307
Roser-König156
Roux56
Roux-Baby56

Roux-Mini56
Rund-, Flachzange396,397
Ruskin129

S

Sachs390
Sagittale Ramusosteotomie145-147
Salzer14
Sanvenero15
Sattelhäkchen53
Sauerbruch58,412,444
Saugeraufsätze96
Saugrohre94,95,96
Scaler, Knochenfeilen300
Scaler, supragingivaler Einsatz292-300
Schädel48
Schalentechnik nach Dr. Iglhaut214,215
Scharfe Doppellöffel116
Scharfe Küretten119
Scharfe Löffel115
Schieblehren66
Schleifsteine324,325
Schmelzmeißel340,341
Schön392
Schwarz380,402
Schnenscheren20
Seldin266,267
Semken33,35
Senn-Green53
Silikatspatel367
Sinus-Krallenhaken144
Sinus-Lift-Küretten142,143
Skalpellgriffe3,5
Skalpellklingen4
Skalpellklingen-Entferner4
Sonic Weld Rx®204-223
Spatel363,380
Spencer21
Splitterzangen42
Spritzen280-284
Spritzenbänke432
Standgefäße428
Steinhäuser164,165
Sterilisierzangen412
Sternberg158
Stevens20
Stewart342
Stieglitz42
Stiellupen68
Stirnlupen69
Stockes370
Stolley379
Stößel113

T

Tamponstopfer226
Taylor33,294
Terry131
Thomas382
Tobold159
Toennis103,107
Toennis-Adson16,28
Tofflemire369
Tohoku48
Tonsillenscheren16
Towner294,295
TRACK 1,0-mm-Distraktoren178-179
TRACK 1,5-mm-Distraktoren183
TRACK 1Plus-Distraktoren182
TRACK 2,0-mm-Distraktoren188
Trepanbohrer151,152
Treyemann390
Tücher, Reinigungs- und Pflegemittel419
Tuchklemmen48
Tweed401

U

Universal394
Universal-Kramponzange404
USA370

Zürich297,330,337,342,351,366,383
Zweifel108
Zwickzangen399-402

V

Verbandschere21
Verbandstofftrommel413
Volkman115

W

W. F. Barry274
Wachs-, Porzellan- und Modellier-
instrumente381-390
Wagner17
Waldsachs-Universal404
Wangenabhalter290
Ward361,384
Ward-Kirkland300
Warwick-James277
Wattespender, Wattebehälter,
Watteabfallbehälter431
Watteträger64
Webster101,103,105
Wedelstaedt341
Weichteilhaken60
Weingart400
Weisheitszahnaken161,162
West121,278
White300,332,334
Who328
Wieder159
Williams-Goldman-Fox329
Williger114,116,120,127
Winter275
Wipphahn-Brenner440,441
Wizard371
Wundhäkchen52,53
Wundhaken54-59
Wurzelheber266-268,271-276
Wurzelspitzenheber277,278

Y

Young163,403
Younger-Good293

Z

Zahle387
Zahnfleischmesser2
Zahnfleischschere16,17,18,29,30
Zahnpinzetten40,41,42
Zahnsonden331-336
Zahnsonden-Ansätze336
Zahnzangen228-263
Zahnzangen Martin Fino, Oberkiefer238,239
Zahnzangen Martin Fino, Unterkiefer240,241
Zahnzangen, Amerikanische Form,
Oberkiefer254-258
Zahnzangen, Amerikanische Form,
Unterkiefer259-261
Zahnzangen, Englische Form,
Oberkiefer228-231
Zahnzangen, Englische Form,
Unterkiefer232-237
Zahnzangen, tiefgreifend262,263
Zeller409
Zementspatel367
Zubehör für MD 62450,451
Zubehör für Minicutter und ME 102460-462
Zubehör für Norm- und Half-Trays437,438
Zubehörsätze für MD 62448,449
Zubehörsätze für ME 102458,459
Zubehörsätze für Minicutter454,455
Zungendrucker159
Zungenspatel160
Zungenzangen163

Index, alphabetical

English

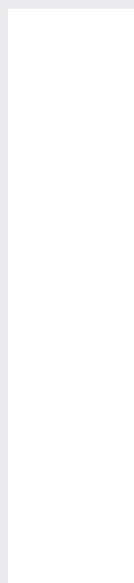
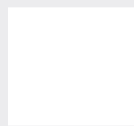

- A**
- Abell405
 Accessories for MD 62450,451
 Accessories for Minicutter
 and ME 102460-462
 Accessories for standard
 and half trays437,438
 Accessory sets for MD 62448,449
 Accessory sets for ME 102458,459
 Accessory sets for Minicutter454,455
 Adams154,403
 Aderer400,403
 Adson32,34,35,46
 Adson-Brown36
 Ainsworth370
 Allen-Iglhaut121,346
 Allis137
 Allis-Baby137
 Alveotomy files127
 Amalgam instruments350
 Angle401,403
 Apical270,271
 Apical-Flohr271
 Applicators64
 Appositions – Onlay Grafts212,213
 Arkansas324,325
 Ash, Gum knives2
 Atraumatic dressing forceps34,33
- B**
- Babcock137,138
 Backhaus48
 Ball type condenser356
 Ball/spatula combination362
 Bandage scissors21
 Bar bending pliers399-402
 Beale387
 Beebee394
 Bein269,272,273
 Beyer129
 Bishop158
 Black340
 Böhler129,130
 Bone carriers153
 Bone crusher150
 Bone curettes115,119
 Bone curettes, double ended118,119
 Bone curettes, double ended116
 Bone cutting forceps130
 Bone files126
 Bone Graft Kit196,203
 Bone mill150
 Bone rongeurs128,129
 Bone spreaders173
 Bonetrap149
 Bonn19
 Brewer370
 Briault333
 Bridge removing pliers404
 Brünings160
 Bruns115
 Buck21
 Buckley110
 Burrs154
- C**
- Calipers66,70
 Cartridge syringes280-284
 Castroviejo100,104
 Cawood-Minnesota158
 Cement mixing spatula367
 Cheattle412
 Cheek retractors290
 Chin holder61
 Chisels110,165
 Chisels, periosteal elevators132
 Chompret277
 Cleaning brushes442,443
- Cleveland128,130
 Coleman271
 Collin163
 Columbia305
 Composite instrument352-354
 Containers420-423
 Contouring pliers405
 Cotton dispensers, waste cotton collector431
 Coupland271
 Crane-Kaplan42
 Crane-Kaplan300
 Crile102
 Crile-Murray101
 Crile-Wood101,103,105
 Cross330
 Crown pliers405
 Crown-Butler391
 Cryer266,267
 Cumine293
 Cups430
 Curettes, subgingival305-307,318,319
 Cuticle scissors408
- D**
- Dean16,30
 DeBaKey34,106
 DeBaKey-Mosquito49
 Denhart156
 Dental forceps40,41,42
 Derf104
 Desmarres53
 Diamant392
 Diethrich-Salyer16
 Dilators174
 Disposable scalpels6
 Dissecting and Ligature Forceps46,47
 Dissecting forceps32,34,35,36
 Dissecting scissors11-16,18,24,26,28,
 Distractors178-193
 Double lever stopcock burner440,441
 Doyen160
 Dressing forceps in jar with cap415
 Dressing sterilizing drums413
 Dumont397
 Dura hooks136
- E**
- Ehrlicke374-377
 Eiselsberg21
 Electrosurgical unit MD 62446,447
 Electrosurgical unit ME 102456,457
 Electrosurgical unit Minicutter452,453
 Elephant foot condenser355
 Elevators127,131,133,134
 Elevators, Graft Packers, Burrs148
 Elite impression trays
 according to Ehrlicke374-377
 Emons120
 Enamel chisels340,341
 End and side nippers399-402
 Epker164
 Excavators337-339
 Explorers331-336
 Explorers interchangeable336
 Extracting forceps228-263
 Extracting forceps for children,
 American pattern, upper jaw248,249
 Extracting forceps for children,
 English pattern, lower jaw246,247
 Extracting forceps for children,
 English pattern, upper jaw242-245
 Extracting forceps Martin Ergo,
 diamond coated, lower jaw252,253
 Extracting forceps Martin Ergo,
 diamond coated, upper jaw250,251
 Extracting forceps Martin Fino,
 lower jaw240,241
- Extracting forceps Martin Fino,
 upper jaw238,239
 Extracting forceps, American pattern,
 lower jaw259-261
 Extracting forceps, American pattern,
 upper jaw254-258
 Extracting forceps, deep-gripping262,263
 Extracting forceps, English pattern,
 lower jaw232-237
 Extracting forceps, English pattern,
 upper jaw228-231
- F**
- Face protection mask409
 Fahrenstock390
 Farabeuf56
 Farrell64
 Felt352,353
 Filling instruments351,358-361,364,365
 Finger protector154
 Flagg41
 Flat nose pliers396,397
 Flohr267
 Foster-Gillies106
 Frahm384
 Frame for Lenses69
 Freer123
 Friedman271
 Friedmann128
 Furrer404
- G**
- Gauze packers226
 Gilles34,35,136
 Gillies106
 Gillies-Mini106
 Gingival cord packer380
 Gingivectomy knives345-347
 Gisy-Wild390
 Goldman-Fox17,29,299,328
 Goldstein353
 Goslee397
 Gouges111
 Gracey310-317,320-323
 Gracey curettes with 10 mm handle316,317
 Gracey mini curettes, subgingival
 310,311,320,321
 Gracey Rigid curettes, subgingival314,315
 Gracey standard curettes,
 subgingival312,313,322,323
 Greenstein388,389
 Gregory100
 Gritmann390
 Gum knives2
 Gum scissors16,17,18,29,30
 Guthrie52
- H**
- Haemostatic forceps44,45,46,47,49
 Half trays436
 Halfpunch for softissue170
 Halsey101,105
 Halsted-Mosquito44,45
 Hammers/mallets406
 Hartmann128,159
 Head loupe68
 Head Loupes69
 Hegar-Baumgartner104
 Heidebrink277,278
 Heidemann365
 Heister155
 Hemingway116
 Henahan161,162
 Herbert114
 HF Surgery446-462
 Hirschfeld300
 Hollenback359,384

Hooklets.....52,53
How.....405
Hygienist.....296
Hylin.....272,387

I

Igihaut.....23,37,99,110,119,121,132,
.....142,165,167-170,174,326
Impression trays.....374-379
Impression trays for partial impressions..378,379
Instrument boxes.....428,429
Instrument trays.....427
Instruments for crown work.....390-392
Iris scissors.....19,20
Ivory.....368,370

J

Jaboma.....23,34,293,298
Johnson.....405
Jones.....48
Joseph.....15,26,136

K

Kahre-Williger.....120
Kelly.....10,20,46
Kidney dishes.....430
Killner.....136
Kirkland.....347
Kocher.....47,55
Kocher-Langenbeck.....54
Körner-Westermann
122,123,142,143,166,171,172
Korund.....324
Krallenheber.....276

L

La-Grange.....18
Lambotte-Mini.....112
Langenbeck.....57,108,154
Langenbeck Mini.....53
Langer.....306
Laryngeal mirrors.....286
Le Cron.....387
Lecluse.....275
Leriche.....46
Lexer-Fino.....13
Lexer-Mini.....111
Lichtenberg.....103,108
Lichtenstein.....380
Lindemann.....154
Lindo-Levian.....267
Lindorf.....144-147
Lip and cheek retractors.....157,158
Lister.....21
Littauer.....21
Locklin.....18,30
London-College.....40
Lucas-Martin.....118
Luer.....129
Luniatshchek.....226
Luxators.....269,270

M

Magnifying glasses.....68
Mallets.....114
Martin.....41,42,160,367,394,395,415,444
Martin Erg-O-Norm.....434-439
Martin-ECO.....416
Martin-Proper.....413
Martin-Simplex.....158
Mathieu.....102,107
Matrix bands.....368,369
Matrix retainers.....368,369
Maunder.....154
Mayfield.....129
Mayo-Hegar.....101,102,105

Mayo-Lexer.....24
McCall.....294,295,305
McKesson.....155
Mead.....114
Measurers.....426
Medicine cups.....429
Meiss.....148
Membrane fixation and Guided Bone
Regeneration.....210,211
Mercitan.....300
Mercury.....328,383
Meriam.....40
Merrit A.....328
Merrit E.....328
Mershon.....390
Metal jars.....428
Metzenbaum.....10,11,12,24,26
Metzenbaum-Fino.....13,14,27,28
Metzenbaum-Lahey.....28
Metzenbaum-Nelson.....11
Michigan.....328
Micro forceps.....37,38
Micro mouth mirrors.....289
Micro needle holders.....98,99,104
Micro scalpel blades.....5
Micro Scissors.....22,23
MicroStop® - Mini-Set containers.....420-423
Middeldorp.....55
Mikro Adson.....36
Mikro Mosquito.....45
Miller.....127,390
Miller-Apexo.....266
Miller-Colburn.....118,126
Mini Adson.....32,36
Mini cement mixing spatula.....366
Mitchell.....293
Mixer-Baby.....47
Molt.....124,125,156
Mouth gags.....154,155,156
Mouth mirror handles.....290
Mouth mirrors.....287,288

N

Nabers.....326,327,336
Nail files.....409
Nail scissors.....408
Needle Cases.....412,413
Needle cases, needle cases, storing cup.....414
Needle holders.....101,102,103,105,
.....106,107,108
Northbent.....20
Nyström.....384

O

Obwegeser.....59,60,61,134,155,158,163
Ochsenbein.....133,165
Ohl.....124
Olsen Hegar.....106
Operating scissors.....8,9,10,15,17,18,24,25,26
Orban.....347
Order and set recommendations
Sonic Weld Rx®.....216-219
Oringer.....157
Osteosynthesis.....194,195
Osteotomes.....111,112,164,166-169,171,172

P

Paris.....390
Partsch.....110,111
Pean.....44,47
Peers- Bertram.....48,49
Peet.....42
Periodontal chisels.....165,303,304
Periodontal file.....301,302
Periodontal probes.....326-330
Periosteal elevators.....120,125,127,133,134
Periotomes.....116,117

Petri dishes.....426
Pitha.....154
Plane condenser.....357
Polisher.....356
Pott.....276
Prichard.....120,319
Probes.....64,140
Protection spectacles.....409

R

Ragnell.....29
Ralk.....42
Ramus osteotomes.....164
Ramus retractors.....163
Retractors.....54-59
Reynolds.....405
Rhodes.....303
Roncati.....302,307
Roncati Fine Kit.....307
Root canal instruments.....342-344
Root elevators.....266-268,271-276
Root fragment elevators.....277,278
Roser-König.....156
Round metal boxes.....429
Roux.....56
Roux-Baby.....56
Roux-Mini.....56
Rubber dam instruments.....370,371
Rulers.....67
Ruskin.....129

S

Sachs.....390
Saddle hooks.....53
Sagittal ramus osteotomies.....145-147
Salzer.....14
Sanvenero.....15
Sauerbruch.....58,412,444
Scalers, bone files.....300
Scalers, supragingival.....292-300
Scalpel blade remover.....4
Scalpel blades.....4
Scalpel handles.....3,5
Schädel.....48
Schön.....392
Schwarz.....380,402
Seldin.....266,267
Semken.....33,35
Senn-Green.....53
Sharpening stones.....324,325
Shell technique acc. to Dr. Igihaut.....214,215
Silicate mixing spatula.....367
Sinus lift currettes.....142,143
Sinus-Krallenhaken.....144
Skin hooklets.....136
Skin hooks.....52
Soft tissue retractors.....60
Sonic Weld Rx®.....204-223
Spatulas.....363,380
Spencer.....21
Splinter forceps.....42
Stainless steel bowls.....426,439
Standard trays.....434,435
Steinhäuser.....164,165
Sterilizing Forceps.....412
Sternberg.....158
Stevens.....20
Stewart.....342
Stieglitz.....42
Stitch scissors.....20,21
Stockes.....370
Stolley.....379
Storing cases.....418
Storing tray.....416,417
Suction cannulas.....94,95,96
Suction tips.....96
Syringe racks.....432

T

Tampers	113
Taylor	33,294
Tendon scissors.....	20
Terry	131
Third molar hook.....	161,162
Thomas	382
Tissue grasping forceps.....	137,138
Tobold.....	159
Toennis	103,107
Toennis-Adson	16,28
Tofflemire.....	369
Tohoku	48
Tongue depressors.....	159
Tongue holding forceps.....	163
Tongue spatulas	160
Tonsil scissors.....	16
Towel clamps.....	48
Towels, cleaning and care agents.....	419
Towner	294,295
TRACK 1.0 mm distractors	178-179
TRACK 1.5 mm distractors	183
TRACK 1Plus distractors.....	182
TRACK 2.0 mm distractors	188
Trephine burs.....	151,152
Treyemann.....	390
Tweed	401

U

Universal.....	394
Universal pliers.....	404
Universal trays.....	427
USA.....	370

V

Vascular forceps.....	39
Volkman	115

W

W. F. Barry.....	274
Wagner.....	17
Waldsachs-Universal.....	404
Ward.....	361,384
Ward-Kirkland.....	300
Warwick-James	277
Waste bucket	444
Wax, porcelain and modelling carvers.....	381-390
Webster.....	101,103,105
Wedelstaedt.....	341
Weingart.....	400
West	121,278
White.....	300,332,334
Who.....	328
Wieder	159
Williams-Goldman-Fox	329
Williger	114,116,120,127
Winter.....	275
Wire cutting pliers.....	398
Wire cutting scissors.....	394
Wire twisting forceps	395
Wire, arch and clasp bending pliers	403
Wizard	371

Y

Young	163,403
Younger-Good	293

Z

Zahle	387
Zeller	409
Zürich.....	297,330,337,342,351,366,383
Zweifel.....	108

Índice, alfabético

Español

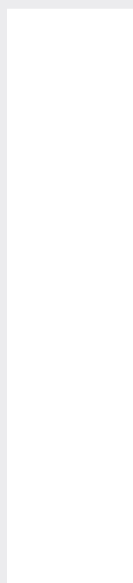
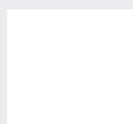

Hemingway.....116
Henahan161,162
Herbert114
Hirschfeld300
Hojas de bisturí4
Hollenback359,384
How405
Hygienist296
Hylin272,387

I

Iglhaut23,37,99,110,119,121,132,
.....142,165,167-170,174,326
Instrumento compuesto352-354
Instrumentos amalgamas350
Instrumentos para canales342-344
Instrumentos para coronas390-392
Instrumentos para hilo retractor380
Instrumentos para obturaciones
.....351,358-361,364,365
Instrumentos para pulir356
Ivory368,370

J

Jaboma23,34,293,298
Jeringas de hueso153
Jeringas para cartucho apollas280-284
Johnson405
Jones48
Joseph15,26,136
Juegos de accesorios para MD 62448,449
Juegos de accesorios para ME 102458,459
Juegos de accesorios para Minicutter454,455

K

Kahre-Williger120
Kelly10,20,46
Killner136
Kirkland347
Kit Bone Graft196,203
Kocher47,55
Kocher-Langenbeck54
Körner-Westermann
.....122,123,142,143,166,171,172
Korund324
Krallenheber276

L

La-Grange18
Lambotte-Mini112
Langenbeck57,108,154
Langenbeck Mini53
Langer306
Le Cron387
Lecluse275
Leriche46
Lexer-Fino13
Lexer-Mini111
Lichtenberg103,108
Lichtenstein380
Lima paradontal301,302
Limas para alveolotomía127
Limas para huesos126
Limas para uñas409
Limpiadores de sarro, limas de hueso300
Limpiadores de sarro, supragingival292-300
Lindemann154
Lindo-Levian267
Lindorf144-147
Lister21
Littauer21
Locklin18,30
London-College40
Lucas-Martin118
Luer129
Luniatshchek226

Lupa frontal68
Lupas68
Lupas frontales69
Luxadores269,270

M

Mangos de bisturí3,5
Mangos para espejos de boca290
Martillos114,406
Martin41,42,160,367,394,395,415,444
Martin Erg-O-Norm434-439
Martin-ECO416
Martin-Propor413
Martin-Simplex158
Mathieu102,107
Matrices368,369
Mauder154
Mayfield129
Mayo-Hegar101,102,105
Mayo-Lexer24
McCall294,295,305
McKesson155
Mead114
Mecheros con llave de palanca doble440,441
Medias bandejas436
Meiss148
Mercitan300
Mercury328,383
Meriam40
Merrit A328
Merrit E328
Mershon390
Metzenbaum10,11,12,24,26
Metzenbaum-Fino13,14,27,28
Metzenbaum-Lahey28
Metzenbaum-Nelson11
Michigan328
Micro hojas de bisturí5
Micro pinzas37,38
Micro porta-agujas98,99,104
MicroStop® - Contenedores Mini-Set420-423
Micro-Tijeras22,23
Middelorp55
Mikro Adson36
Mikro Mosquito45
Miller127,390
Miller-Apexo266
Miller-Colburn118,126
Mini Adson32,36
Mini espátula para cemento366
Mitchell293
Mixer-Baby47
Molino de huesos150
Molt124,125,156

N

Nabers326,327,336
Northbent20
Nyström384

O

Obwegeser59,60,61,134,155,158,163
Ochsenbein133,165
Ohl124
Olsen Hegar106
Orban347
Oringer157
Osteosíntesis194,195
Osteotomía sagital de
rama mandibular145-147
Osteótomos111,112,164,166-169,171,172
Osteótomos de rama164

P

Paños, detergentes y productos de curación...419
Paris390

Partsch110,111
Pean44,47
Peers- Bertram48,49
Peet42
Periostótomos, legros120,125,127,133,134
Periótomos116,117
Piedras de afilar324,325
Pinza en tarro con tapa415
Pinzas40,41,42
Pinzas cortantes para hueso130
Pinzas de campo48
Pinzas de disección32,34,35,36
Pinzas de disección atraumática34,33
Pinzas de disección vasculares39
Pinzas gubias128,129
Pinzas hemostáticas44,45,46,47,49
Pinzas para espinas42
Pinzas para esterilización412
Pinzas para preparación y ligadura46,47
Pinzas para tejidos137,138
Pinzas para torcer alambre395
Pinzas tira-lengua163
Pitha154
Porta algodones64
Porta-agujas101,102,103,105,106,107,108
Portamatrices368,369
Pott276
Prichard120,319
Protector de cara409
Punta de succión96
Punzones metálicos113

Q

Quita-hojas4

R

Ragnell29
Ralk42
Recomendaciones de pedido
y de sets Sonic Weld Rx®216-219
Reglas67
Reynolds405
Rhodes303
Riñoneras430
Roncati302,307
Roncati Fine Kit307
Roser-König156
Roux56
Roux-Baby56
Roux-Mini56
Ruskin129

S

Sachs390
Salzer14
Sanvenero15
Sauerbruch58,412,444
Schädel48
Schön392
Schwarz380,402
Seldin266,267
Semken33,35
Senn-Green53
Separador para mentón61
Separadores290
Separadores54-59
Separadores de huesos173
Separadores para el ramo163
Separadores para labios y mejillas157,158
Separadores para partes blandas60
Separador-garra sinus144
Sondas64
Sondas331-336
Sondas abotonadas140
Sondas intercambiables336
Sondas paradontales326-330
Sonic Weld Rx®204-223

Spencer	21
Steinhäuser	164,165
Sternberg	158
Stevens	20
Stewart	342
Stieglitz	42
Stockes	370
Stolley	379

T

Talladores y espátulas para cera, porcelana y modelar	381-390
Tambores para esterilización.....	413
Taponeadores.....	226
Tarros.....	430
Tarros metálicos	428
Taylor	33,294
Técnica de valva según Dr. Iglhaut.....	214,215
Terry	131
Thomas	382
Tijeras cuticulares	408
Tijeras de disección.....	11-16,18,24,26,28,
Tijeras para alambre	394
Tijeras para amígdalas	16
Tijeras para encías.....	16,17,18,29,30
Tijeras para hilos.....	20,21
Tijeras para iridectomía.....	19,20
Tijeras para tendones.....	20
Tijeras para uñas	408
Tijeras para vendajes	21
Tijeras quirúrgicas.....	8,9,10,15,17,18,24,25,26
Tobold.....	159
Toennis	103,107
Toennis-Adson	16,28
Tofflemire.....	369
Tohoku	48
Towner	294,295
TRACK 1,0 mm distractores.....	178-179
TRACK 1,5 mm distractores.....	183
TRACK 1Plus distractores	182
TRACK 2,0 mm distractores.....	188
Tray para depositar	416,417
Trephine.....	151,152
Treyemann.....	390
Tubos de aspiración.....	94,95,96
Tweed	401

U

Universal.....	394
USA.....	370

V

Vaso-medidas	426
Vasos medicinales	429
Volkman	115

W

W. F. Barry.....	274
Wagner.....	17
Waldsachs-Universal	404
Ward	361,384
Ward-Kirkland	300
Warwick-James	277
Webster.....	101,103,105
Wedelstaedt.....	341
Weingart.....	400
West	121,278
White.....	300,332,334
Who	328
Wieder	159
Williams-Goldman-Fox	329
Williger	114,116,120,127
Winter.....	275
Wizard	371

Y

Young	163,403
Younger-Good	293

Z

Zahle	387
Zeller	409
Zürich.....	297,330,337,342,351,366,383
Zweifel.....	108

Index alphabétique

Français

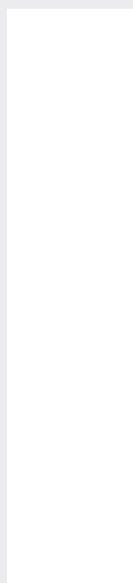
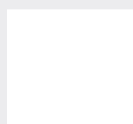

- A**
- Abaisse-langue.....159,160
 Abell.....405
 Accessoires pour MD 62.....450,451
 Accessoires pour Minicutter
 et ME 102.....460-462
 Accessoires pour trays standard
 et semi-trays.....437,438
 Adams.....154,403
 Aderer.....400,403
 Adson.....32,34,35,46
 Adson-Brown.....36
 Ainsworth.....370
 Allen-Ighaut.....121,346
 Allis.....137
 Allis-Baby.....137
 Angle.....401,403
 Apical.....270,271
 Apical-Flohr.....271
 Appareil électrochirurgical MD 62.....446,447
 Appareil électrochirurgical ME 102.....456,457
 Appareil électrochirurgical Minicutter.....452,453
 Arkansas.....324,325
 Ash, Couteaux à gencives.....2
- B**
- Babcock.....137,138
 Backhaus.....48
 Baïllons.....154,155
 Bassins réiniformes.....430
 Beale.....387
 Becs pour la laboratoire.....440,441
 Beebee.....394
 Bein.....269,272,273
 Beyer.....129
 Bishop.....158
 Bistouris à usage unique.....6
 Bistouris pour la gingivectomie.....345-347
 Black.....340
 Böhler.....129,130
 Boîtes de Petri.....426
 Boîtes pour aiguilles.....412,413
 Boîtes pour aiguilles, boîtes pour
 aiguilles, gobelet pour instruments.....414
 Boîtes pour instruments.....428,429
 Boîtes pour instruments.....429
 Boîtes pour stérilisation de pansements.....413
 Boîtes pour stockage.....418
 Bonn.....19
 Brewer.....370
 Briault.....333
 Brosses à lavement.....442,443
 Broeyer d'os.....150
 Brünings.....160
 Bruns.....115
 Buck.....21
 Buckley.....110
 Burins de parodontie.....165,303,304
 Burins, élévateurs du périoste.....132
- C**
- Cadres à deux lentilles.....69
 Castroviejo.....100,104
 Cawood-Minnesota.....158
 Cheattle.....412
 Chirurgie HF.....446-462
 Chompret.....277
 Cisailles à fils.....394
 Ciseaux à dissection.....11-16,18,24,26,28,
 Ciseaux à émail.....340,341
 Ciseaux à envies.....408
 Ciseaux à iridectomie.....19,20
 Ciseaux à ligatures.....20,21
 Ciseaux à ongles.....408
 Ciseaux à ténotomie.....20
 Ciseaux burins.....110
 Ciseaux chirurgicaux.....8,9,10,15,17,
 18,24,25,26
- Ciseaux pour gencives.....16,17,18,29,30
 Ciseaux pour les amygdales.....16
 Ciseaux pour pansements.....21
 Ciseaux-burins.....165
 Cleveland.....128,130
 Coleman.....271
 Collecteur d'os.....149
 Collin.....163
 Columbia.....305
 Combinaison bille/spatule.....362
 Combinaison couvercle/pince.....415
 Compas.....70
 Conteneurs.....420-423
 Coupland.....271
 Couteaux à gencives.....2
 Crane-Kaplan.....42
 Crane-Kaplan.....300
 Crile.....102
 Crile-Murray.....101
 Crile-Wood.....101,103,105
 Crochet à dent de sagesse.....161,162
 Crochets.....52,53
 Crochets pour dure mère.....136
 Crochets pour la peau.....52
 Cross.....330
 Crown-Butler.....391
 Cryer.....266,267
 Cumine.....293
 Curettes.....119
 Curettes doubles.....116,118,119
 Curettes pour sinus lift.....142,143
 Curettes tranchantes.....115
 Curettes, subgingival.....305-307,318,319
 Cuvettes de acier inoxydable.....426,439
- D**
- Daviers.....228-263
 Daviers Martin Ergo,
 mandibule inférieure.....252,253
 Daviers Martin Fino,
 mandibule supérieure.....250,251
 Daviers Martin Fino,
 mandibule inférieure.....240,241
 Daviers Martin Fino,
 mandibule supérieure.....238,239
 Daviers pour enfants, forme américaine,
 mandibule supérieure.....248,249
 Daviers pour enfants, forme anglaise,
 mandibule inférieure.....246,247
 Daviers pour enfants, forme anglaise,
 mandibule supérieure.....242-245
 Daviers, à attaque profonde.....262,263
 Daviers, forme américaine,
 mandibule inférieure.....259-261
 Daviers, forme américaine,
 mandibule supérieure.....254-258
 Daviers, forme anglaise,
 mandibule inférieure.....232-237
 Daviers, forme anglaise,
 mandibule supérieure.....228-231
 Dean.....16,30
 DeBaKey.....34,106
 DeBaKey-Mosquito.....49
 Denhart.....156
 Derf.....104
 Desmarres.....53
 Diamant.....392
 Diethrich-Salyer.....16
 Dilatateurs.....174
 Distracteurs.....178-193
 Distributeurs de coton, porte-déchets.....431
 Doigtiers.....154
 Doyen.....160
 Dumont.....397
- E**
- Ecarteur pour menton.....61
 Ecarteurs.....54-59,290
- Ecarteurs des lèvres et joues.....157,158
 Ecarteurs pour parties molles.....60
 Ecarteurs pour ramus.....163
 Ecarteurs sous forme de selle.....53
 Ehrlicke.....374-377
 Eiselsberg.....21
 Élévateurs.....127,131,133,134
 Élévateurs de fragments de racines.....277,278
 Élévateurs de racines.....266-268,271-276
 Élévateurs, Pousoirs pour
 transplantation, Mèches.....148
 Emons.....120
 Enlève-lame.....4
 Epker.....164
 Erignes cutanées.....136
 Excavateurs.....337-339
- F**
- Fahnenstock.....390
 Farabeuf.....56
 Farrell.....64
 Felt.....352,353
 Fixation de membrane et
 Guided Bone Regeneration.....210,211
 Flagg.....41
 Flohr.....267
 Foster-Gillies.....106
 Frahm.....384
 Fraises à carotter tréphine.....151,152
 Freer.....123
 Friedman.....271
 Friedmann.....128
 Furrer.....404
- G**
- Gilles.....34,35,136
 Gillies.....106
 Gillies-Mini.....106
 Gisy-Wild.....390
 Gobelets.....429
 Goldman-Fox.....17,29,299,328
 Goldstein.....353
 Goslee.....397
 Gouges.....111
 Gracey.....310-317,320-323
 Gracey curettes avec manches
 à 10 mm.....316,317
 Gracey curettes standard, subgingival
312,313,322,323
 Gracey mini curettes, subgingival
310,311,320,321
 Gracey Rigid curettes, subgingival.....314,315
 Greenstein.....388,389
 Greffes d'apposition – Onlay Grafts.....212,213
 Gregory.....100
 Gritmann.....390
 Guthrie.....52
- H**
- Halsey.....101,105
 Halsted-Mosquito.....44,45
 Hartmann.....128,159
 Hegar-Baumgartner.....104
 Heidebrink.....277,278
 Heidemann.....365
 Heister.....155
 Hemingway.....116
 Henahan.....161,162
 Herbert.....114
 Hirschfeld.....300
 Hollenback.....359,384
 How.....405
 Hygienist.....296
 Hylin.....272,387

I
Iglhaut 23,37,99,110,119,121,132,
..... 142,165,167-170,174,326
Instrument composite 352-354
Instruments à amalgame 350
Instruments à canaux 342-344
Instruments à détartrer, râpes à os 300
Instruments à détartrer, supragingival 292-300
Instruments à modeler 381-390
Instruments de couronnes 390-392
Instruments kofferdam 370,371
Instruments pour fil retracteur 380
Instruments pour plombages
..... 351,358-361,364,365
Ivory 368,370

J
Jaboma 23,34,293,298
Jeux d'accessoires pour MD 62 448,449
Jeux d'accessoires pour ME 102 458,459
Jeux d'accessoires pour Minicutter 454,455
Johnson 405
Jones 48
Joseph 15,26,136

K
Kahre-Williger 120
Kelly 10,20,46
Killner 136
Kirkland 347
Kit pour greffe osseuse 196,203
Kocher 47,55
Kocher-Langenbeck 54
Körner-Westermann
..... 122,123,142,143,166,171,172
Korund 324
Krallenheber 276

L
La-Grange 18
Lambotte-Mini 112
Lames de bistouris 4
Langenbeck 57,108,154
Langenbeck Mini 53
Langer 306
Le Cron 387
Lecluse 275
Leriche 46
Lexer-Fino 13
Lexer-Mini 111
Lichtenberg 103,108
Lichtenstein 380
Lime parodontale 301,302
Limes à ongles 409
Limes à os 126
Limes pour alvéolotomie 127
Lindemann 154
Lindo-Levian 267
Lindorf 144-147
Linges, agents de nettoyage et d'entretien 419
Lister 21
Littauer 21
Locklin 18,30
London-College 40
Loupe frontale 68
Loupes 68
Loupes frontales 69
Lucas-Martin 118
Luer 129
Lunettes protectrices 409
Luniatshchek 226
Luxateurs 269,270

M
Maillets 114
Manches pour bistouris 3,5

Manches pour miroirs à bouche 290
Marteaux 406
Martin 41,42,160,367,394,395,415,444
Martin Erg-O-Norm 434-439
Martin-ECO 416
Martin-Propre 413
Martin-Simplex 158
Mathieu 102,107
Matrices 368,369
Maunder 154
Mayfield 129
Mayo-Hegar 101,102,105
Mayo-Lexer 24
McCall 294,295,305
McKesson 155
Mead 114
Mèches 154
Meiss 148
Mercitan 300
Mercury 328,383
Meriam 40
Merrit A 328
Merrit E 328
Mershon 390
Mesures graduées 426
Metzenbaum 10,11,12,24,26
Metzenbaum-Fino 13,14,27,28
Metzenbaum-Lahey 28
Metzenbaum-Nelson 11
Meules 324,325
Michigan 328
Micro lames de bistouris 5
Micro porte-aiguilles 98,99,104
Micro-Ciseaux 22,23
Micro-pinces 37,38
MicroStop® - conteneurs Mini-Set 420-423
Middeldorp 55
Mikro Adson 36
Mikro Mosquito 45
Miller 127,390
Miller-Apexo 266
Miller-Colburn 118,126
Mini Adson 32,36
Mini spatule à plâtre 366
Miroirs à bouche 287,288
Miroirs à bouche micro 289
Miroirs laryngiens 286
Mitchell 293
Mixer-Baby 47
Molt 124,125,156

N
Nabers 326,327,336
Northbent 380
Nyström 384

O
Obturbateur à bille 356
Obturbateur pied d'éléphant 355
Obturbateur plan 357
Obwegeser 59,60,61,134,155,158,163
Ochsenbein 133,165
Ohl 124
Olsen Hegar 106
Orban 347
Oringer 157
Ostéosynthèse 194,195
Ostéotome pour ramus 164
Ostéotomes 111,112,164,166-169,171,172
Ostéotomie sagittale du ramus 145-147
Ouvre-bouche 155,156

P
Paris 390
Partsch 110,111
Pean 44,47
Peers- Bertram 48,49

Peet 42
Periotomes 116,117
Pieds à coulisse 66
Pilons métalliques 113
Pincés 399-402
Pincés à champs 48
Pincés à couper le fil, pincés coupantes
de côté 398
Pincés à courber les branches 399-402
Pincés à courber les fils, les branches
et les agrafes 403
Pincés à couronne 405
Pincés à disséquer et à ligatures 46,47
Pincés à dissection 32,34,35,36
Pincés à dissection vasculaires 39
Pincés à échardes 42
Pincés à torsader le fil 395
pincés atraumatiques à dissection 34,33
Pincés coupantes à os 130
Pincés des contours 405
Pincés d'extraction de bridge 404
Pincés gouges 128,129
Pincés hémostatiques 44,45,46,47,49
Pincés plates, rondes 396,397
Pincés pour instruments stérilisés 412
Pincés pour tissus 137,138
Pincés tire-langue 163
Pincés universelles 404
Pitha 154
Plateau pour déposer instruments 416,417
Plateaux pour instruments 427
Plateaux universaux 427
Pointe de succion 96
Polissoir 356
Porte cotons 64
Porte empreintes 374-379
Porte empreintes partiels 378,379
Porte empreintes selon Ehrlicke 374-377
Porte matrices 368,369
Porte-aiguilles 101,102,103,105,106,107,108
Porte-tampon 226
Pott 276
Précelles 40,41,42
Presse d'os 150
Prichard 120,319
Protecteur facial 409

R
Ragnell 29
Ralk 42
Récipients 430
Récipients en méta 428
Recommandations pour les commandes
et les sets Sonic Weld Rx® 216-219
Règles à mesurer 67
Retracteur sinus griffe 144
Reynolds 405
Rhodes 303
Roncati 302,307
Roncati Fine Kit 307
Roser-König 156
Roux 56
Roux-Baby 56
Roux-Mini 56
Rugines raspatoires, rugines
..... 120,125,127,133,134
Ruskin 129

S
Sachs 390
Salzer 14
Sanvenero 15
Sauerbruch 58,412,444
Schädel 48
Schön 392
Schwarz 380,402
Seau pour déchets 444
Seldin 266,267

Semistance ppour tissu.....	170
Semi-trays.....	436
Semken.....	33,35
Senn-Green.....	53
Séparateurs d'os.....	173
Seringues à ampoule.....	280-284
Seringues à os.....	153
Sondes.....	64,331-336
Sondes boutonnées.....	140
Sondes interchangeable.....	336
Sondes parodontales.....	326-330
Sonic Weld Rx®.....	204-223
Spatule à plâtre.....	367
Spatule à silicate.....	367
Spatules.....	363,380
Spencer.....	21
Steinhäuser.....	164,165
Sternberg.....	158
Stevens.....	20
Stewart.....	342
Stieglitz.....	42
Stockes.....	370
Stolley.....	379
Support pour seringues.....	432

T

Taylor.....	33,294
Technique à coquille selon Dr. Igthaut....	214,215
Terry.....	131
Thomas.....	382
Tobold.....	159
Toennis.....	103,107
Toennis-Adson.....	16,28
Tofflemire.....	369
Tohoku.....	48
Towner.....	294,295
TRACK 1,0 mm distracteurs.....	178-179
TRACK 1,5 mm distracteurs.....	183
TRACK 1Plus distracteurs.....	182
TRACK 2,0 mm distracteurs.....	188
Trays standard.....	434,435
Treyemann.....	390
Tubes d'aspiration.....	94,95,96
Tweed.....	401

U

Universal.....	394
USA.....	370

V

Volkman.....	115
--------------	-----

W

W. F. Barry.....	274
Wagner.....	17
Waldsachs-Universal.....	404
Ward.....	361,384
Ward-Kirkland.....	300
Warwick-James.....	277
Webster.....	101,103,105
Wedelstaedt.....	341
Weingart.....	400
West.....	121,278
White.....	300,332,334
Who.....	328
Wieder.....	159
Williams-Goldman-Fox.....	329
Williger.....	114,116,120,127
Winter.....	275
Wizard.....	371

Y

Young.....	163,403
Younger-Good.....	293

Z

Zahle.....	387
Zeller.....	409
Zürich.....	297,330,337,342,351,366,383
Zweifel.....	108

Indice, alfabetico

Italiano

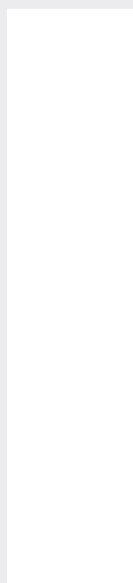
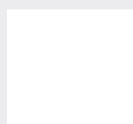

Leve per radici.....	266-268,271-276
Lexer-Fino	13
Lexer-Mini	111
Lichtenberg	103,108
Lichtenstein	380
Lima periodontale	301,302
Lime per alveolotomia.....	127
Lime per ossa	126
Lime per unghie.....	409
Lindemann	154
Lindo-Levian.....	267
Lindorf.....	144-147
Lister	21
Littauer	21
Locklin.....	18,30
London-College	40
Lucas-Martin	118
Lucidatore	356
Luer.....	129
Luniatshchek.....	226
Luxatori.....	269,270

M

Manici per bisturi.....	3,5
Manici per specchietti	290
Martelli	114,406
Martin.....	41,42,160,367,394,395,415,444
Martin Erg-O-Norm.....	434-439
Martin-ECO	416
Martin-Propor	413
Martin-Simplex	158
Mathieu	102,107
Matrici	368,369
Maunder	154
Mayfield.....	129
Mayo-Hegar	101,102,105
Mayo-Lexer.....	24
McCall	294,295,305
McKesson	155
Mead	114
Meiss	148
Mercitan	300
Mercury.....	328,383
Meriam	40
Merrit A	328
Merrit E	328
Mershon.....	390
Metzenbaum.....	10,11,12,24,26
Metzenbaum-Fino	13,14,27,28
Metzenbaum-Lahey	28
Metzenbaum-Nelson.....	11
Michigan.....	328
Micro lame per bisturi	5
Micro portagli	98,99,104
Micro-Forbici	22,23
Micro-pinze	37,38
MicroStop® - contenitori Mini-Set	420-423
Middeldorp.....	55
Mikro Adson	36
Mikro Mosquito.....	45
Miller	127,390
Miller-Apexo	266
Miller-Colburn.....	118,126
Mini Adson	32,36
Mini spatola per cemento.....	366
Misuratori.....	67
Mitchell	293
Mixer-Baby	47
Molt.....	124,125,156
Montatura metallica	69

N

Nabers.....	326,327,336
Northbent.....	20
Nyström	384

O

Obwegeser.....	59,60,61,134,155,158,163
Occhiali protettivi.....	409
Ochsenbein	133,165
Ohl	124
Olsen Hegar.....	106
Orban	347
Oringer	157
Osteosintesi.....	194,195
Osteotomi	111,112,164,166-169,171,172
Osteotomi per ramo.....	164
Osteotomia sagittale del ramo	145-147
Otturatore a piede di elefante.....	355
Otturatore a sfera	356
Otturatore piano.....	357
Otturatori	351,358-361,364,365

P

Panni, detergenti e prodotti di cura.....	419
Paris.....	390
Partsch	110,111
Pean	44,47
Peers- Bertram.....	48,49
Peet.....	42
Periostotomi	120,125,127,133,134
Periotomi	116,117
Pestoni metallici	113
Pietre per affilare	324,325
Pinza-coperchio	415
Pinze	40,41,42
Pinze atraumatiche	34,33
Pinze emostatiche.....	44,45,46,47,49
Pinze fissatele	48
Pinze per dissezione	32,34,35,36
Pinze per dissezione vascolari	39
Pinze per estrazione	228-263
Pinze per estrazione Martin Ergo,	
mascella inferiore.....	252,253
Pinze per estrazione Martin Ergo,	
mascella superiore	250,251
Pinze per estrazione Martin Fino,	
mascella inferiore.....	240,241
Pinze per estrazione Martin Fino,	
mascella superiore	238,239
Pinze per estrazione per bambini,	
forma americana, mascella superiore ..	248,249
Pinze per estrazione per bambini,	
forma inglese, mascella inferiore	246,247
Pinze per estrazione per bambini,	
forma inglese, mascella superiore	242-245
Pinze per estrazione, forma americana,	
mascella inferiore.....	259-261
Pinze per estrazione, forma americana,	
mascella superiore.....	254-258
Pinze per estrazione, forma inglese,	
mascella inferiore.....	232-237
Pinze per estrazione, forma inglese,	
mascella superiore	228-231
Pinze per estrazione, profondo.....	262,263
Pinze per lingua	163
Pinze per preparazioni e legature	46,47
Pinze per ritorcere fili	395
Pinze per schegge	42
Pinze per strumenti sterilizzati	412
Pinze per tessuti	137,138
Pinze sgorbie	128,129
Pitha.....	154
Porta cotoni.....	64
Portagli	101,102,103,105,106,107,108
Portaimpronte.....	374-379
Portaimpronte Ehricke	374-377
Portaimpronte parziali	378,379
Portamatrici.....	368,369
Pott	276
Prichard	120,319
Protettore per dita	154
Protettore facciale.....	409
Punte per aspirazione	96

R

Raccoglio osso	149
Ragnell	29
Ralk.....	42
Recipienti	430
Recipienti metallici	428
Reynolds	405
Rhodes	303
Roncati	302,307
Roncati Fine Kit.....	307
Roser-König.....	156
Roux.....	56
Roux-Baby.....	56
Roux-Mini	56
Ruskin	129

S

Sachs	390
Salzer	14
Sanvenero	15
Sauerbruch.....	58,412,444
Scalpelli.....	110
Scalpelli	165
Scalpelli, leve periostali	132
Scatole per aghi	412,413
Scatole per aghi, scatole per aghi,	
contenitore per strumenti.....	414
Scatole per magazzino	418
Scatole per sterilizzare bendaggi.....	413
Scatole per strumenti	428,429
Schädel.....	48
Schön	392
Schwarz	380,402
Scodella di Petri	426
Scodelle di acciaio inossidabile	426,439
Secchia per rifiuti	444
Seldin.....	266,267
Semi-bacinelle.....	436
Sempunzonatri tessuto	170
Semken	33,35
Senn-Green	53
Separatore per ramo	163
Separatori per labbra e guancia	157,158
Separatori per ossa.....	173
Serie di accessori per MD 62	448,449
Serie di accessori per ME 102.....	458,459
Serie di accessori per Minicutter.....	454,455
Sgorbie	111
Sgorbie per parodontologia.....	165,303,304
Siringhe ampollari	280-284
Siringhe per osso	153
Sonde	64,331-336
Sonde a bottone.....	140
Sonde intercambiabili.....	336
Sonde parodontali	326-330
Sonic Weld Rx®.....	204-223
Spatola per cemento.....	367
Spatola per la mescolatura di silicone	367
Spatole	363,380
Spatole per lingua	160
Spazzole per pulire.....	442,443
Specchi laringei	286
Specchietti	287,288
Specchietti micro.....	289
Spencer	21
Steinhäuser	164,165
Sternberg	158
Stevens.....	20
Stewart	342
Stieglitz	42
Stockes	370
Stolley	379
Strumenti per amalgama.....	350
Strumenti per corone.....	390-392
Strumenti per fili di retrazione.....	380
Strumenti per modellare	381-390
Strumenti per trattamenti canalari	342-344
Strumento composito	352-354

Strumento per schiacciamento ossa150
Supporto per siringhe432

T

Tagliasmalto340,341
Tamponatori226
Taylor33,294
Tecnica a guscio secondo Dr. Iglhaut.....214,215
Tenaglie399-402
Tenaglie per corone405
Tenaglie per la piegatura di fili metallici,
 staffe e graffe403
Tenaglie per la piegatura di staffe399-402
Tenaglie per la rimozione di ponticelli404
Tenaglie per profili405
Tenaglie piatte396,397
Tenaglie tagliafilari, tenaglie tagliafilari laterali398
Tenaglie universali.....404
Terry131
Thomas382
Tobold.....159
Toennis103,107
Toennis-Adson16,28
Tofflemire.....369
Tohoku48
Towner294,295
TRACK 1,0 mm distrattori178-179
TRACK 1,5 mm distrattori183
TRACK 1Plus distrattori182
TRACK 2,0 mm distrattori188
Treyemann.....390
Tubi d'aspirazione94,95,96
Tweed401

U

Uncini cutanei136
Uncini per dura madre.....136
Uncino per dente del giudizio.....161,162
Universal.....394
USA.....370

V

Volkman115

W

W. F. Barry.....274
Wagner.....17
Waldsachs-Universal.....404
Ward361,384
Ward-Kirkland.....300
Warwick-James277
Webster.....101,103,105
Wedelstaedt.....341
Weingart.....400
West121,278
White300,332,334
Who328
Wieder159
Williams-Goldman-Fox329
Williger114,116,120,127
Winter.....275
Wizard371

Y

Young163,403
Younger-Good293

Z

Zahle387
Zeller409
Zürich.....297,330,337,342,351,366,383
Zweifel.....108



03.09 · 90-138-48-05 · Printed in Germany · Copyright by Gebrüder Martin GmbH & Co. KG · Alle Rechte vorbehalten · Technische Änderungen vorbehalten
We reserve the right to make alterations · Cambios técnicos reservados · Sous réserve de modifications techniques · Ci riserviamo il diritto di modifiche tecniche

Karl Leibinger GmbH & Co. KG

78570 Mühlheim · Germany
Tel. +49 7463 838-0
info@klsmartin.com

KLS Martin GmbH + Co. KG

79224 Umkirch · Germany
Tel. +49 7665 9802-0
info@klsmartin.com

Stuckenbrock Medizintechnik GmbH

78532 Tuttlingen · Germany
Tel. +49 7461 161114
verwaltung@stuckenbrock.de

Rudolf Buck GmbH

78570 Mühlheim · Germany
Tel. +49 7463 99516-30
info@klsmartin.com

KLS Martin France SARL

68000 Colmar · France
Tel. +33 3 89216601
france@klsmartin.com

Martin Italia S.r.l.

20059 Vimercate (MB) · Italy
Tel. +39 039 6056731
italia@klsmartin.com

Nippon Martin K.K.

Osaka 541-0046 · Japan
Tel. +81 6 62289075
nippon@klsmartin.com

Martin Nederland/Marned B.V.

1270 AG Huizen · The Netherlands
Tel. +31 35 5234538
nederland@klsmartin.com

Gebrüder Martin GmbH & Co. KG

Representative Office
121471 Moscow · Russia
Tel. +7 (499) 792-76-19
russia@klsmartin.com

KLS Martin L.P.

Jacksonville, FL 32246 · USA
Office phone +1 904 6417746
usa@klsmartin.com

Orthosurgical Implants Inc.

Miami, FL 33186 · USA
Office phone +1 877 9694545
sales@orthosurgical.com

Gebrüder Martin GmbH & Co. KG

Ein Unternehmen der KLS Martin Group

Ludwigstaler Str. 132 · D-78532 Tuttlingen
Postfach 60 · D-78501 Tuttlingen
Tel. +49 7461 706-0 · Fax 706-193
info@klsmartin.com
www.klsmartin.com