

Level One Fixation

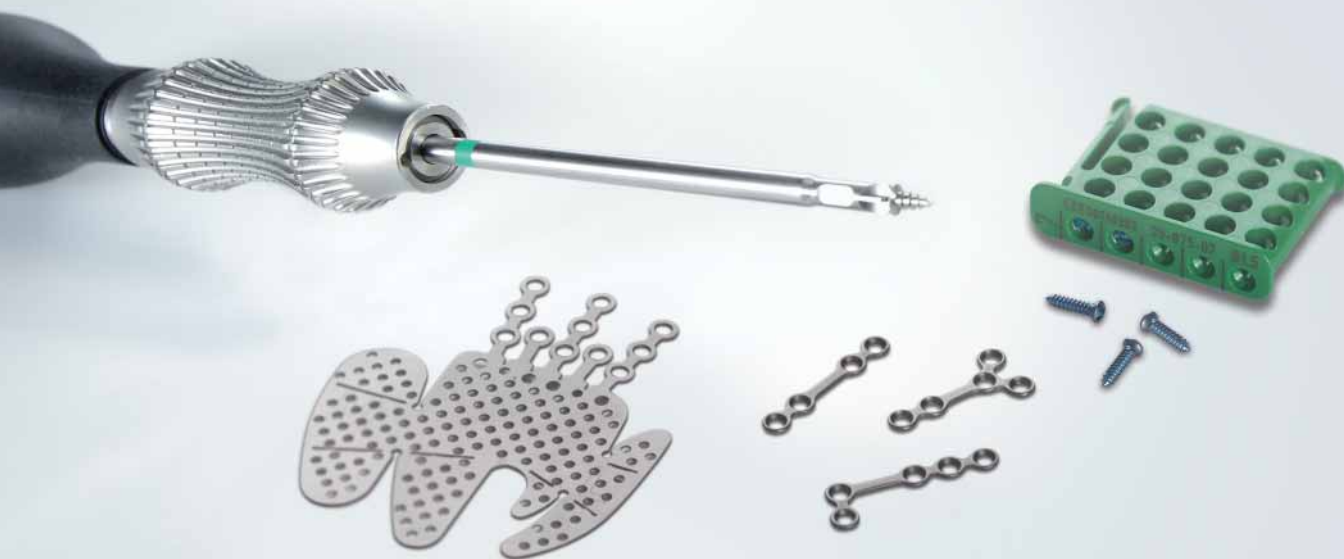

Osteosynthese 1.5 Mikro
Osteosynthesis 1.5 Micro
Osteosíntesis 1.5 Micro
Ostéosynthèse 1.5 Micro
Osteosintesi 1.5 Micro

1.5-mm-Mikro-System

1.5 mm Micro System

Sistema Micro 1.5 mm

Système Micro 1.5 mm

Sistema Micro da 1.5 mm



Indikationen

- Neurochirurgie
- Frontaler und Maxillärer Sinus
- Naso- und Infra-Orbital-Region
- Fixierung von Knochentransplantaten
- Kieferorthopädische Eingriffe
- Distraction
- Mittelgesichtstraumen

Indications

- Neurosurgery
- Frontal and maxillary sinus
- Naso- and intra-orbital region
- Fixation of bone grafts
- Ortho-anchorage
- Distraction
- Midfacial trauma

Indicaciones

- Neurocirugía
- Seno frontal y maxilar
- Región nasal e infraorbital
- Fijación de trasplantes óseos
- Intervenciones de ortodoncia
- Distracción
- Traumatismos de la parte media de la cara

Indications

- Neurochirurgie
- Sinus frontal et maxillaire
- Région nasale et intra-orbitale
- Fixation de greffons d'os
- Interventions d'orthodontie
- Distraction
- Traumatismes médiofaciaux

Indicazioni

- Neurochirurgia
- Seno frontale e mascellare
- Regione nasale e infraorbitale
- Fissaggio degli innesti ossei
- Interventi ortodontici
- Distrazione
- Fratture mediofacciali



KLS-Martin-Titan-Implantate (Platten) bestehen aus Reintitan in Implantatqualität nach DIN ISO 5832-2, DIN 17850 und ASTM F 67.

KLS-Martin-Titan-Implantate (Schrauben) bestehen aus einer Titan-Legierung (Ti-6Al-4V) in Implantatqualität nach DIN ISO 5832-3, DIN 17851 und ASTM F 136a.

KLS Martin titanium implants (plates) are made of pure titanium in implant quality according to DIN ISO 5832-2, DIN 17850 and ASTM F 67.

KLS Martin implants (e.g. screws) are made of titanium alloy (Ti-6Al-4V) according to DIN ISO 5832-3, DIN 17851 and ASTM F 136a.

Los implantes de titanio de KLS Martin (placas) están formados de titanio puro en calidad de implante conforme a DIN ISO 5832-2, DIN 17850 y ASTM F 67.

Los implantes de titanio de KLS Martin (tornillos) están formados por una aleación de titanio (Ti-6Al-4V) en calidad de implante conforme a DIN ISO 5832-3, DIN 17851 y ASTM F 136a.

Les implants en titane (plaques) de KLS Martin sont composés de titane pur dans la qualité pour implants conformément à DIN ISO 5832-2, DIN 17850 et ASTM F 67.

Les implants en titane (vis) de KLS Martin sont composés d'un alliage de titane (Ti-6Al-4V) dans la qualité pour implants conformément à DIN ISO 5832-3, DIN 17851 et ASTM F 136a.

Gli impianti in titanio (placche) KLS Martin sono fatti di titanio puro in qualità da impianti in conformità alla DIN ISO 5832-2, DIN 17850 e ASTM F 67.

Gli impianti al titanio KLS Martin (per esempio le viti) sono fatti in lega di titanio (Ti-6Al-4V) in conformità alla DIN ISO 5832-3, DIN 17851 e ASTM F 136a.

Mikro-Schrauben 1.5 mm

Micro Screws 1.5 mm
Tornillos Micro, 1.5 mm
Vis Micro 1.5 mm
Viti Micro da 1.5 mm



Titan
Titanium
Titanio
Titane
Titanio



Verkaufsmenge pro Verpackungseinheit
Quantity / units per package
Número de unidades por embalaje
Nombre d'unités par emballage
Quantità di vendita per unità d'imballo



Steril verpackte Implantate
Sterile packed implants
Implantes embalados de forma estéril
Implants emballés de manière stérile
Impianti imballati sterilmente

Centre Drive®



Mikro-Schrauben
Micro Screws
Tornillos Micro
Vis Micro
Viti Micro

selbsthaltend
self-retaining
autobloqueantes
autobloquante
autoritativa

	Centre Drive®		STERILE R
	1.5 x 3.5 mm	25-665-03-09	25-665-03-75
	1.5 x 4 mm	25-665-04-09	25-665-04-75
	1.5 x 5 mm	25-665-05-09	25-665-05-75
	1.5 x 6 mm	25-665-06-09	25-665-06-75
	1.5 x 7 mm	25-665-07-09	25-665-07-75
	1.5 x 8 mm	25-665-08-09	25-665-08-75
	1.5 x 9 mm	25-665-09-09	25-665-09-75
	1.5 x 11 mm	25-665-11-09	25-665-11-75
	1.5 x 13 mm	25-665-13-09	25-665-13-75
	1.5 x 15 mm	25-665-15-09	25-665-15-75

maxDrive®



Mikro-Schrauben
Micro Screws
Tornillos Micro
Vis Micro
Viti Micro

selbsthaltend
self-retaining
autobloqueantes
autobloquante
autoritativa

	maxDrive®		STERILE R
	1.5 x 3.5 mm	25-875-03-09	25-875-03-75
	1.5 x 4 mm	25-875-04-09	25-875-04-75
	1.5 x 5 mm	25-875-05-09	25-875-05-75
	1.5 x 6 mm	25-875-06-09	25-875-06-75
	1.5 x 7 mm	25-875-07-09	25-875-07-75
	1.5 x 8 mm	25-875-08-09	25-875-08-75
	1.5 x 9 mm	25-875-09-09	25-875-09-75
	1.5 x 11 mm	25-875-11-09	25-875-11-75
	1.5 x 13 mm	25-875-13-09	25-875-13-75
	1.5 x 15 mm	25-875-15-09	25-875-15-75
	1.5 x 17 mm	25-875-17-09	
	1.5 x 19 mm	25-875-19-09	

Notfallschrauben
Emergency Screws
Tornillos de emergencia
Vis d'urgence
Viti di emergenza

selbsthaltend
self-retaining
autobloqueantes
autobloquante
autoritativa

	Centre Drive®		STERILE R
	1.8 x 3.5 mm	25-666-03-09	25-666-03-75
	1.8 x 5 mm	25-666-05-09	25-666-05-75
	1.8 x 7 mm	25-666-07-09	25-666-07-75

Notfallschrauben
Emergency Screws
Tornillos de emergencia
Vis d'urgence
Viti di emergenza

selbsthaltend
self-retaining
autobloqueantes
autobloquante
autoritativa

	maxDrive®		STERILE R
	1.8 x 3.5 mm	25-876-03-09	25-876-03-75
	1.8 x 4 mm	25-876-04-09	
	1.8 x 5 mm	25-876-05-09	25-876-05-75
	1.8 x 7 mm	25-876-07-09	25-876-07-75

Drill-Free-Schrauben
Drill-Free-Screws
Tornillos Drill-Free
Vis autoforeuses
Viti Drill Free autoporforanti

selbsthaltend
self-retaining
autobloqueantes
autobloquante
autoritativa

	Centre Drive®		STERILE R
	1.5 x 4 mm	25-668-04-09	25-668-04-75
	1.5 x 5 mm	25-668-05-09	25-668-05-75
	1.5 x 6 mm	25-668-06-09	25-668-06-75
	1.5 x 7 mm	25-668-07-09	25-668-07-75

Drill-Free-Schrauben
Drill-Free-Screws
Tornillos Drill-Free
Vis autoforeuses
Viti Drill Free autoporforanti

selbsthaltend
self-retaining
autobloqueantes
autobloquante
autoritativa

	maxDrive®		STERILE R
	1.5 x 3.5 mm	25-878-03-09	
	1.5 x 4 mm	25-878-04-09	25-878-04-75
	1.5 x 5 mm	25-878-05-09	25-878-05-75
	1.5 x 6 mm	25-878-06-09	
	1.5 x 7 mm	25-878-07-09	25-878-07-75



Cross Drive



Mikro-Schrauben	selbsthaltend
Micro Screws	self-retaining
Tornillos Micro	autobloqueantes
Vis Micro	autobloquante
Viti Micro	autoritensiva

	Cross Drive		STERILE R
	1.5 x 3.5 mm	25-675-03-09	25-675-03-75
1.5 x 4 mm	25-675-04-09	25-675-04-75	
1.5 x 5 mm	25-675-05-09	25-675-05-75	
1.5 x 6 mm	25-675-06-09	25-675-06-75	
1.5 x 7 mm	25-675-07-09	25-675-07-75	
1.5 x 8 mm	25-675-08-09	25-675-08-75	
1.5 x 9 mm	25-675-09-09	25-675-09-75	
1.5 x 11 mm	25-675-11-09	25-675-11-75	
1.5 x 13 mm	25-675-13-09	25-675-13-75	
1.5 x 17 mm	25-675-15-09	25-675-15-75	

Notfallschrauben	selbsthaltend
Emergency Screws	self-retaining
Tornillos de emergencia	autobloqueantes
Vis d'urgence	autobloquante
Viti di emergenza	autoritensiva

	Cross Drive		STERILE R
	1.8 x 3.5 mm	25-676-03-09	25-676-03-75
1.8 x 5 mm	25-676-05-09	25-676-05-75	
1.8 x 7 mm	25-676-07-09	25-676-07-75	

Drill-Free-Schrauben	selbsthaltend
Drill-Free-Screws	self-retaining
Tornillos Drill-Free	autobloqueantes
Vis autoforeuses	autobloquante
Viti Drill Free autopercoranti	autoritensiva

	Cross Drive		STERILE R
	1.5 x 4 mm	25-678-04-09	25-678-04-75
1.5 x 5 mm	25-678-05-09	25-678-05-75	
1.5 x 6 mm	25-678-06-09	25-678-06-75	
1.5 x 7 mm	25-678-07-09	25-678-07-75	



25-650-02-04
 Messclip für Schraubenlänge, grün
 Measuring clip for screw length, green
 Clip de medición para longitud de tornillos, verde
 Jauge de longueur de vis, verte
 Clip di misurazione per la lunghezza della vite, verde



25-651-01-04
 Messclip für Schraubendurchmesser
 Measuring clip for screw diameter
 Clip de medición para diámetro de tornillo
 Jauge de diamètre de vis
 Clip di misurazione per il diametro della vite

Schraubendreher-Übersicht

Screwdriver Overview

Sinopsis de destornilladores

Vue d'ensemble des tournevis

Quadro sinottico cacciaviti

St

Edelstahl
Stainless steel
Acero inoxidable
Acier inoxydable
Acciaio inossidabile



1

Verkaufsmenge pro Verpackungseinheit
Quantity / units per package
Número de unidades por embalaje
Nombre d'unités par emballage
Quantità di vendita per unità d'imballo











STERILE R

Steril verpackte Implantate
Sterile packed implants
Implantes embalados de forma estéril
Implants emballés de manière stérile
Impianti imballati sterilmente

Schraubendreher und Klagen Screwdrivers and Blades Destornilladores y terminales Tournevis et lames Cacciaviti e lame

Centre Drive® 
Cross Drive 
maxDrive® 



Klingen passend für Blades suitable for Mechas apropiadas para Lames pour Lame adatte per	25-480-99-07 *	25-402-99-07 *	25-407-03-04	25-407-04-04 *	25-407-05-04 *
25-431-98-07  1.5 mm	x				
25-430-98-07  1.5 mm		x			
25-432-98-07  1.5 mm	x				
25-483-97-07  1.5 mm		x			
25-432-97-07  1.5 mm Neuro		x			
25-431-97-07  1.5 mm Neuro			x	x	x
25-489-97-07  1.5 mm		x			
25-485-97-07  1.5 mm Neuro		x			
25-438-97-07  1.5 mm			x	x	x
25-433-97-07  1.5 mm Neuro			x	x	x
25-433-98-07  1.5 mm L			x	x	x

* Zur Lagerung in den Level-One-Modulen
For storage in Level One modules
Para almacenaje dentro de los módulos Level One
Pour le stockage dans les modules Level One
Per immagazzinare nel modulo Level One

Schraubendreher, starr, nicht demontierbar Screwdriver, rigid, not removable Destornillador, rígido, no desmontable Tournevis, regide, non amovibile Cacciavite, fissa, non removibile



25-432-16-07  1.5 mm
25-483-13-07  1.5 mm
25-486-15-07  1.5 mm

Bone-Graft-Schraubendreher Bone Graft Screwdrivers Destornilladores Bone Graft Tournevis pour extraire la spongieuse Cacciaviti per Bone Graft



25-422-15-07  1.5 mm
25-423-15-07  1.5 mm
25-424-15-07  1.5 mm

Vorbohrer für 1.5-mm-Mikro-System

Twist Drills for 1.5-mm Micro System

Brocas para sistema Micro 1.5 mm

Mèches de préforage pour système Micro 1.5 mm

Frese per sistema Micro da 1.5 mm

Osteosynthese 1.5 Mikro

Osteosynthesis 1.5 Micro

Osteosintesis 1.5 Micro

Ostéosynthèse 1.5 Micro

Osteosintesi 1.5 Micro



Vorbohrer Twist drills Brocas Mèches de préforage Frese



J-Kupplung / J-Notch / Conexión-J / Conexion-J / Connessione-J

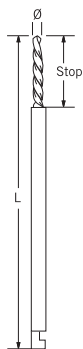

Ø x L (mm)	Stop (mm)	STERILE R	
1.1 x 50	–	25-452-00-07	5
1.1 x 50	–	25-452-00-91	1
1.1 x 50	–	25-452-00-71	1
1.1 x 50	3.5	25-452-03-07	5
1.1 x 50	3.5	25-452-03-91	1
1.1 x 50	5	25-452-05-07	5
1.1 x 50	5	25-452-05-91	1
1.1 x 50	5	25-452-05-71	1
1.1 x 50	7	25-452-07-07	5
1.1 x 50	7	25-452-07-91	1
1.1 x 50	7	25-452-07-71	1
1.1 x 50	9	25-452-09-07	5
1.1 x 50	9	25-452-09-91	1
1.1 x 50	9	25-452-09-71	1
1.1 x 50	15	25-452-15-07	5
1.1 x 50	15	25-452-15-91	1
1.1 x 50	15	25-452-15-71	1
1.1 x 105	3.5	50-511-35-07	1
1.1 x 105	3.5	50-511-35-71	1
1.1 x 105	5	50-511-05-07	1
1.1 x 105	5	50-511-05-71	1
1.1 x 105	7	25-452-57-07	1
1.1 x 105	7	25-452-57-71	1
1.1 x 105	21	25-452-61-07	1
1.1 x 105	21	25-452-61-71	1



Dental-Ansatz / Dental attachment/Sujeción tipo dental / Embout dentaire / Connessione dentalea

Ø x L (mm)	Stop (mm)		
1.1 x 30	17	50-920-00-07	1
1.1 x 20	7	50-920-07-07	1



Mikro-Platten 1.5 mm

Micro Plates 1.5 mm
 Placas Micro, 1.5 mm
 Plaques Micro 1.5 mm
 Placche Micro da 1.5 mm



Platten-Profil
 Plate profile
 Perfil de la placa
 Profil de la plaque
 Profilo placce



Titan
 Titanium
 Titanio
 Titane
 Titanio



Verkaufsmenge pro Verpackungseinheit
 Quantity / units per package
 Número de unidades por embalaje
 Nombre d'unités par emballage
 Quantità di vendita per unità d'imballo

STERILE IR

Steril verpackte Implantate
 Sterile packed implants
 Implantes embalados de forma estéril
 Implants emballés de manière stérile
 Impianti imballati sterilmente

25-302-12-09	25-302-70-09	25-304-00-09	25-304-55-09	25-304-70-09
25-302-12-91	25-302-70-91	25-304-00-91	25-304-55-91	25-304-70-91
25-302-12-71	25-302-70-71	25-304-00-71	25-304-55-71	25-304-70-71
= 0.6 mm	= 0.6 mm	= 0.6 mm	= 0.6 mm	= 0.6 mm

25-304-85-09	25-306-00-09	25-306-55-09	25-306-70-09	25-306-85-09
25-304-85-91	25-306-00-91	25-306-55-91	25-306-70-91	25-306-85-91
25-304-85-71	25-306-00-71	25-306-55-71	25-306-70-71	25-306-85-71
= 0.6 mm	= 0.6 mm	= 0.6 mm	= 0.6 mm	= 0.6 mm







25-308-00-09	25-316-00-09
25-308-00-91	25-316-00-91
25-308-00-71	25-316-00-71
= 0.6 mm	= 0.6 mm

25-320-00-09	25-330-24-09
25-320-00-91	25-330-24-71
25-320-00-71	= 0.6 mm
= 0.6 mm	

25-325-06-09	25-325-08-09	25-325-10-09
25-325-06-91	25-325-08-91	25-325-10-91
25-325-06-71	25-325-08-71	25-325-10-71
= 0.6 mm	= 0.6 mm	= 0.6 mm









1/4 

25-310-55-09  
 25-310-55-91  
 25-310-55-71  







 = 0.6 mm





25-311-55-09  
 25-311-55-91  
 25-311-55-71  







 = 0.6 mm





25-310-70-09  
 25-310-70-91  
 25-310-70-71  







 = 0.6 mm





25-311-70-09  
 25-311-70-91  
 25-311-70-71  







 = 0.6 mm

1/4 

25-310-85-09  
 25-310-85-91  
 25-310-85-71  







 = 0.6 mm





25-311-85-09  
 25-311-85-91  
 25-311-85-71  





 = 0.6 mm



25-312-55-09  
 25-312-55-91  
 25-312-55-71  







 = 0.6 mm



25-313-55-09  
 25-313-55-91  
 25-313-55-71  

 = 0.6 mm

1/4 

25-312-70-09  
 25-312-70-91  
 25-312-70-71  







 = 0.6 mm





25-313-70-09  
 25-313-70-91  
 25-313-70-71  







 = 0.6 mm





25-312-85-09  
 25-312-85-91  
 25-312-85-71  





 = 0.6 mm





25-313-85-09  
 25-313-85-91  
 25-313-85-71  







 = 0.6 mm

1/4 

25-314-85-09  
 25-314-85-91  
 25-314-85-71  

 = 0.6 mm



25-315-85-09  
 25-315-85-91  
 25-315-85-71  

 = 0.6 mm

Mikro-Platten 1.5 mm

Micro Plates 1.5 mm
Placas Micro, 1.5 mm
Plaques Micro 1.5 mm
Placche Micro da 1.5 mm



Platten-Profil
Plate profile
Perfil de la placa
Profil de la plaque
Profilo placce



Titan
Titanium
Titanio
Titane
Titanio



Verkaufsmenge pro Verpackungseinheit
Quantity / units per package
Número de unidades por embalaje
Nombre d'unités par emballage
Quantità di vendita per unità d'imballo

STERILE IR

Steril verpackte Implantate
Sterile packed implants
Implantes embalados de forma estéril
Implants emballés de manière stérile
Impianti imballati sterilmente



1/1

25-315-06-09
25-315-06-91
25-315-06-71
 = 0.6 mm



100° 80°

25-316-06-91
 = 0.6 mm



80° 100°

25-317-06-91
 = 0.6 mm



25-330-07-09
25-330-07-71
 = 0.6 mm



1/1

25-320-55-09
25-320-55-91
25-320-55-71
 = 0.6 mm



25-320-70-09
25-320-70-91
25-320-70-71
 = 0.6 mm



25-320-85-09
25-320-85-91
25-320-85-71
 = 0.6 mm



25-329-05-09
25-329-05-71
 = 0.6 mm



1/1

25-322-55-09
25-322-55-91
25-322-55-71
 = 0.6 mm



25-322-70-09
25-322-70-91
25-322-70-71
 = 0.6 mm



25-322-85-09
25-322-85-91
25-322-85-71
 = 0.6 mm



1/1

25-326-55-09
25-326-55-91
25-326-55-71
 = 0.6 mm



25-328-12-09
25-328-12-91
25-328-12-71
 = 0.6 mm



25-329-01-09
25-329-01-71
 = 0.6 mm



25-329-02-09
25-329-02-71
 = 0.6 mm



100°
 $\frac{1}{2}$

25-330-70-09 Ti 5
 25-330-70-91 Ti 1
25-330-70-71 Ti 1
 = 0.6 mm

100°

25-331-70-09 Ti 5
 25-331-70-91 Ti 1
25-331-70-71 Ti 1
 = 0.6 mm

100°

25-330-05-09 Ti 1
25-330-05-71 Ti 1
 = 0.6 mm

100°

25-331-05-09 Ti 1
25-331-05-71 Ti 1
 = 0.6 mm

100°
 $\frac{1}{2}$

25-330-85-09 Ti 5
 25-330-85-91 Ti 1
25-330-85-71 Ti 1
 = 0.6 mm

100°

25-331-85-09 Ti 5
 25-331-85-91 Ti 1
25-331-85-71 Ti 1
 = 0.6 mm

100°

25-330-10-09 Ti 5
 25-330-10-91 Ti 1
25-330-10-71 Ti 1
 = 0.6 mm

100°

25-331-10-09 Ti 5
 25-331-10-91 Ti 1
25-331-10-71 Ti 1
 = 0.6 mm

100°
 $\frac{1}{2}$

25-336-11-09 Ti 5
 25-336-11-91 Ti 1
25-336-11-71 Ti 1
 = 0.6 mm

100°

25-337-11-09 Ti 5
 25-337-11-91 Ti 1
25-337-11-71 Ti 1
 = 0.6 mm

Kieferorthopädische Schrauben und Platten

Orthodontic screws and plates
Tornillos y placas para la ortodoncia
Vis et plaques orthodontiques
Viti e placche ortodontiche



Platten-Profil
Plate profile
Perfil de la placa
Profil de la plaque
Profilo placce



Titan
Titanium
Titanio
Titane
Titanio



Verkaufsmenge pro Verpackungseinheit
Quantity / units per package
Número de unidades por embalaje
Nombre d'unités par emballage
Quantità di vendita per unità d'imballo

Kieferorthopädische Schrauben (ohne Clipmagazin)
Orthodontic screws (w/o clip magazine)
Tornillos para la ortodoncia (sin depósito sujetatornillos)
Vis orthodontiques (sans chargeur à clip)
Viti ortodontiche (senza contenitore-clip per viti)

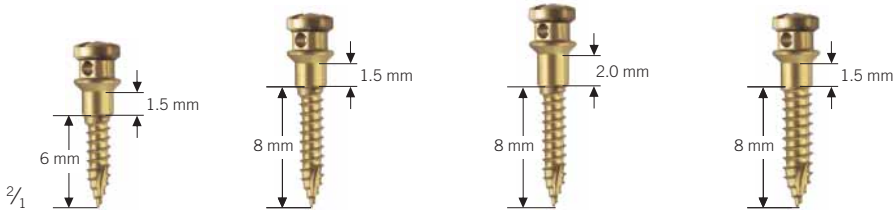

50-340-08-09	50-340-10-09	50-340-12-09	50-345-13-09
Cross Drive	Cross Drive	Cross Drive	Cross Drive
1.5 x 11 mm	1.5 x 13 mm	1.5 x 13.5 mm	2.0 x 13 mm

Clipmagazin leer für Schrauben
Clip magazine empty for screws
Clip vacío para tornillos
Support à clip vide pour vis
Clip vuoto per viti

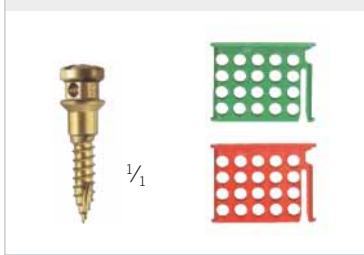

50-340-08-09	99-340-08-04
50-340-10-09	99-340-10-04
50-340-12-09	99-340-12-04
50-340-13-09	99-340-13-04

Centre Drive®
Knorpelschrauben
Cartilage screws
Tornillos para cartilago
Vis pour cartilage
Viti per cartilagine



25-068-04-09	1.5 x 4 mm
25-068-06-09	1.5 x 6 mm
25-068-08-09	1.5 x 8 mm
25-068-10-09	1.5 x 10 mm

(ohne Clipmagazin)
(w/o clip magazine)
(sin depósito sujetatornillos)
(sans chargeur à clip)
(senza contenitore-clip per viti)

Chondrosynthese-Platten zur Kehlkopfrekonstruktion
Chondrosynthesis plates for laryngeal reconstruction
Placas de condrosíntesis para la reconstrucción de la laringe
Implants pour reconstruction laryngée
Placche per condrosintesi per la ricostruzione della laringe



25-346-16-09
 = 0.6 mm



Kieferorthopädische Platten, entwickelt in Zusammenarbeit mit:
 Orthodontic plates, designed in cooperation with:
 Placas para la ortodoncia, diseñado en cooperación con:
 Plaques orthodontiques, développé en collaboration avec:
 Placche ortodontiche, progettato in collaborazione con:

Prof. Dr. Kyu Rhim Chung
 Kyung-Hee University Hospital, Seoul, South-Korea

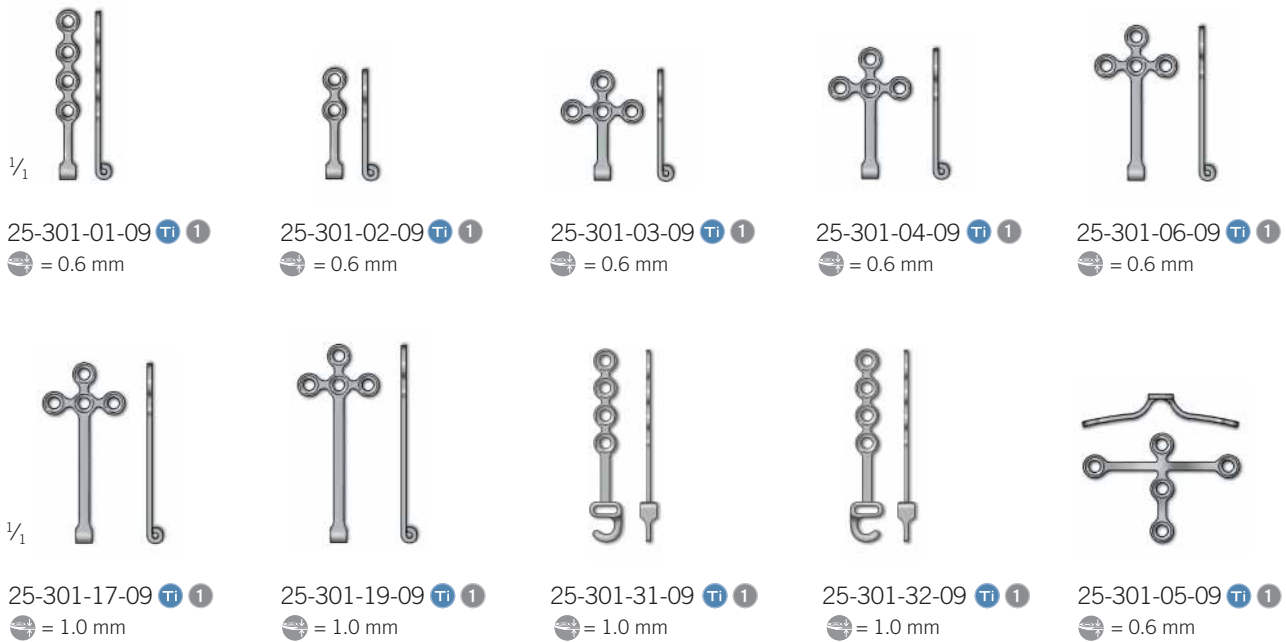

55-961-28-04

Lagerungsmodul komplett, ohne Inhalt
 Storage module complete, no contents
 Módulo completo sin contenido
 Modul complet sans contenu
 Modulo completo senza contenuto



bestehend aus:
 consisting of:
 formado por:
 compose de:
 consistente in:

55-962-07-04 Insertmodul Insert module Módulo de inserción Module inserts Modulo insert	55-964-53-04 Insert 1 Insert 1 Elemento insertable 1 Insert 1 Inserto 1	55-964-54-04 Insert 2 Insert 2 Elemento insertable 2 Insert 2 Inserto 2	55-963-44-04 Deckel Lid Tapa Couvercle Coperchio
--------------------------------------------------------------------------------------------------------	----------------------------------------------------------------------------------------	----------------------------------------------------------------------------------------	-----------------------------------------------------------------

3D-Mesh 1.5 mm

3D Mesh 1.5 mm

Malla 3D 1.5 mm

Mesh 3D 1.5 mm

Mesh 3D da 1.5 mm



Platten-Profil
Plate profile
Perfil de la placa
Profil de la plaque
Profilo placce



Titan
Titanium
Titanio
Titane
Titanio



Verkaufsmenge pro Verpackungseinheit
Quantity / units per package
Número de unidades por embalaje
Nombre d'unités par emballage
Quantità di vendita per unità d'imballo

STERILE IR

Steril verpackte Implantate
Sterile packed implants
Implantes embalados de forma estéril
Implants emballés de manière stérile
Impianti imballati sterilmente

3D-Mesh

- Dieses Mesh-Design ermöglicht die dreidimensionale Konturierung, ohne dass es dabei zu unerwünschter Faltenbildung oder Überlappung kommt.
- Gestattet dem Chirurgen die exakte Anpassung an die anatomischen Gegebenheiten.
- Einsatz in Verbindung mit KLS-Martin-Drill-Free-Schrauben der Größe 1.5 mm.

3D Mesh

- Mesh design provides 3-dimensional contouring without unwanted wrinkled or overlapped areas.
- Allows the surgeon to match the patient's unique anatomical features.
- Used in conjunction with KLS Martin Drill-Free 1.5 mm screws.

Malla 3D

- El diseño de la malla proporciona un moldeado tridimensional sin áreas arrugadas o superpuestas.
- Permite que el cirujano pueda adaptarlas a las características anatómicas únicas del paciente.
- Se utiliza junto con los tornillos Drill-Free de KLS Martin de 1.5 mm.

Mesh 3D

- Le design du Mesh donne un contour en 3 dimensions sans zones de plis indésirables ou qui se chevauchent.
- Permet au chirurgien de s'adapter exactement aux caractéristiques anatomiques spécifiques du patient.
- Utilisation en liaison avec les vis Drill-Free de 1.5 mm de KLS Martin.

Mesh 3D

- Il design Mesh fornisce profili tridimensionali senza zone rugose o sovrapposte indesiderate.
- Permette al chirurgo di adattarsi alle caratteristiche anatomiche uniche del paziente.
- Si usa con le viti KLS Martin Drill-Free da 1.5 mm.

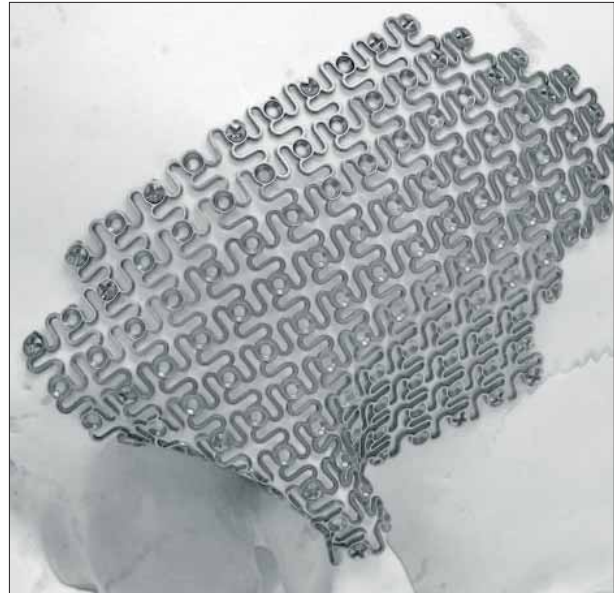

1/1

25-007-80-09 80 x 80 mm = 0.3 mm

25-007-80-71 80 x 80 mm = 0.3 mm

25-008-80-09 80 x 80 mm = 0.6 mm

25-008-80-71 80 x 80 mm = 0.6 mm

Osteosynthese 1.5 Mikro

Osteosynthesis 1.5 Micro
Osteosintesis 1.5 Micro
Ostéosynthèse 1.5 Micro
Osteosintesi 1.5 Micro



25-008-12-09  1 120 x 120 mm
 = 0.6 mm

25-008-20-09  1 200 x 200 mm
 = 0.6 mm

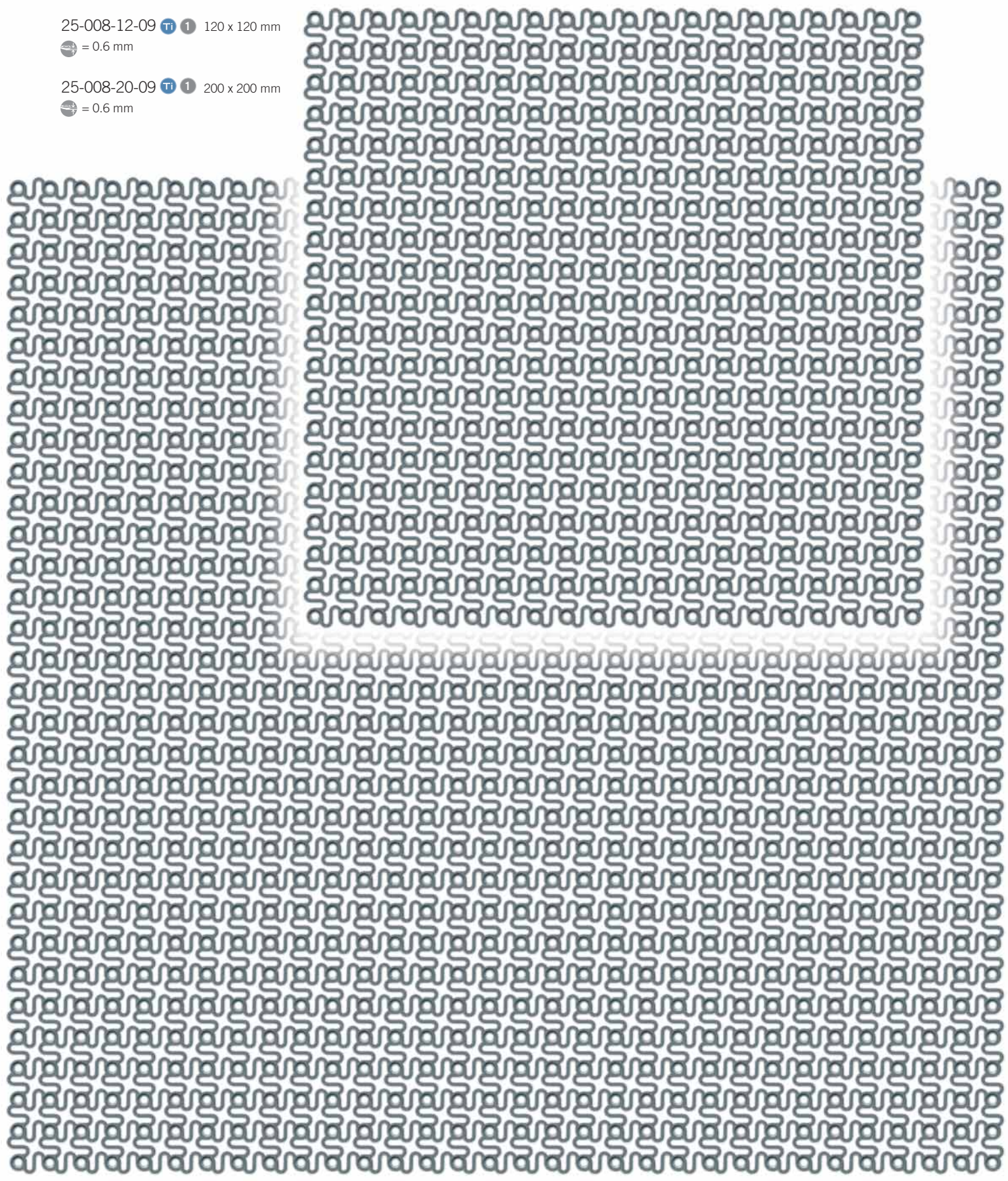

Mikro-Mesh 1.5 mm

Micro Mesh 1.5 mm

Micro malla 1.5 mm

Mesh Micro 1.5 mm

Mesh Micro da 1.5 mm

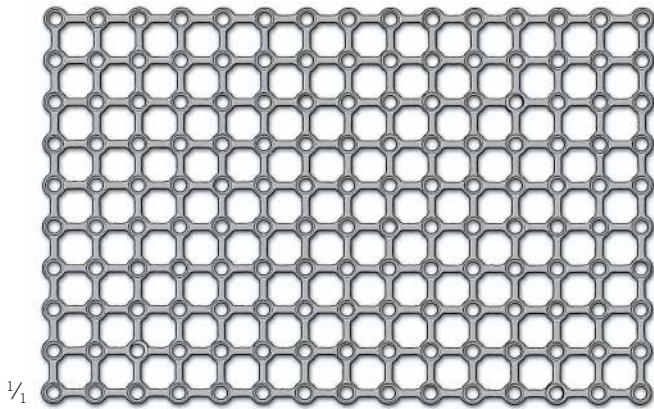

25-005-12-09   80 x 53 mm  = 0.3 mm

25-005-12-71   80 x 53 mm  = 0.3 mm

25-006-12-09   80 x 53 mm  = 0.6 mm

25-006-12-71   80 x 53 mm  = 0.6 mm

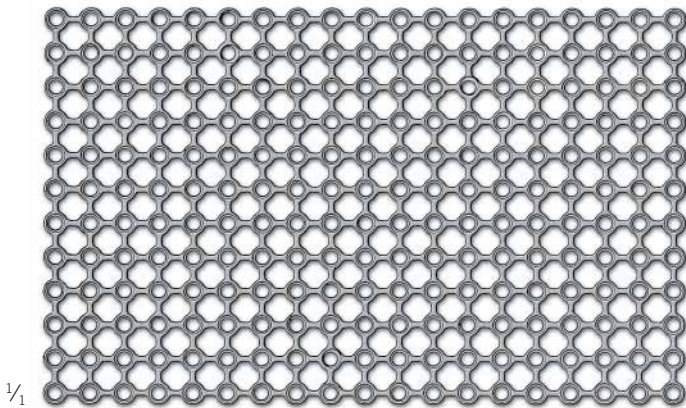

25-003-10-09   84 x 53 mm  = 0.3 mm



25-003-10-71   84 x 53 mm  = 0.3 mm

25-005-10-09   84 x 53 mm  = 0.6 mm

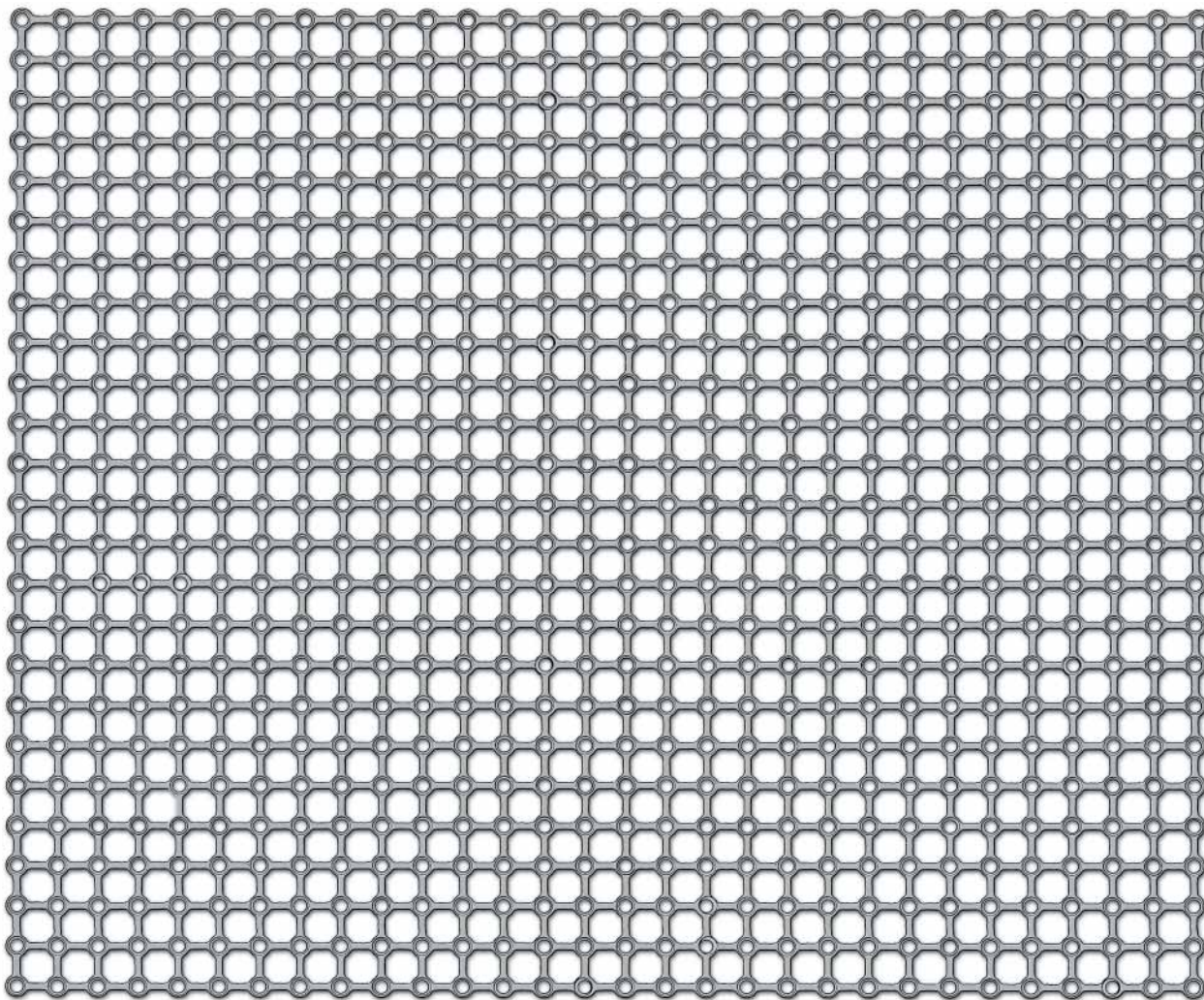
25-005-10-71   84 x 53 mm  = 0.6 mm



1/1

25-004-25-09  

163 x 135 mm

 = 0.6 mm

Zur Überbrückung größerer Defekte bietet unser Mesh-Programm spezielle große Mesh-Platten, etwa zur Behandlung kranialer Defekte oder zur Rekonstruktion des Unterkiefers.

Large mesh sheets are available for bridging large defects (e.g. cranial defects) and for mandibular reconstruction.

Para la conexión de defectos de mayor tamaño, nuestra gama de mallas ofrece soluciones de tamaño especial, por ejemplo para el tratamiento de defectos craneales o para la reconstrucción de la mandíbula.

Pour ponter des défauts assez importants, notre gamme de Mesh propose de grandes plaques de Mesh spéciales, par exemple pour traiter des défauts crâniens ou pour la reconstruction mandibulaire.

Per ponticellare i difetti maggiori il nostro programma a rete Mesh offre speciali placche Mesh grandi, per il trattamento dei difetti del cranio o per la ricostruzione della mandibola.

Mikro-Mesh 1.5 mm

Micro Mesh 1.5 mm
 Micro malla 1.5 mm
 Mesh Micro 1.5 mm
 Mesh Micro da 1.5 mm



Platten-Profil
 Plate profile
 Perfil de la placa
 Profil de la plaque
 Profilo placce



Titan
 Titanium
 Titium
 Titano
 Titane
 Titanio



Verkaufsmenge pro Verpackungseinheit
 Quantity / units per package
 Número de unidades por embalaje
 Nombre d'unités par emballage
 Quantità di vendita per unità d'imballo

STERILE IR

Steril verpackte Implantate
 Sterile packed implants
 Implantes embalados de forma estéril
 Implants emballés de manière stérile
 Impianti imballati sterilmente

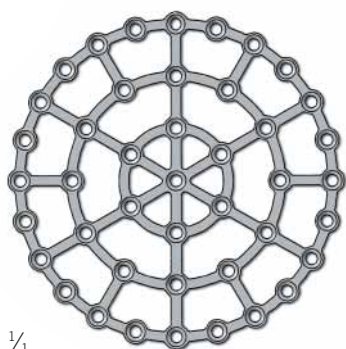

1/4

25-004-50-09

25-004-50-71

Ø = 45 mm

= 0.6 mm

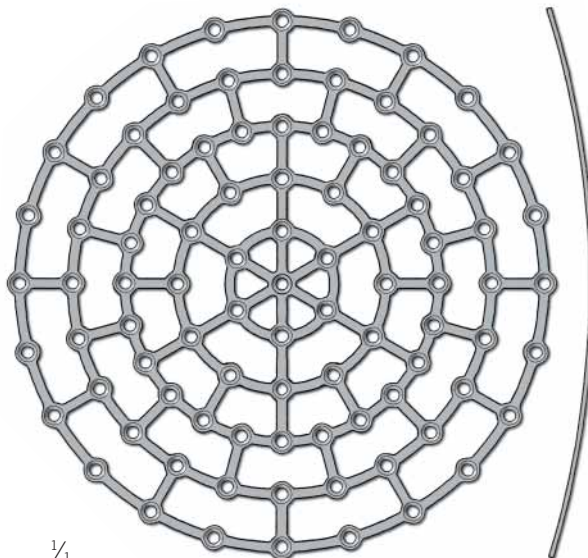

1/4

25-004-70-09

25-004-70-71

Ø = 73 mm

= 0.6 mm

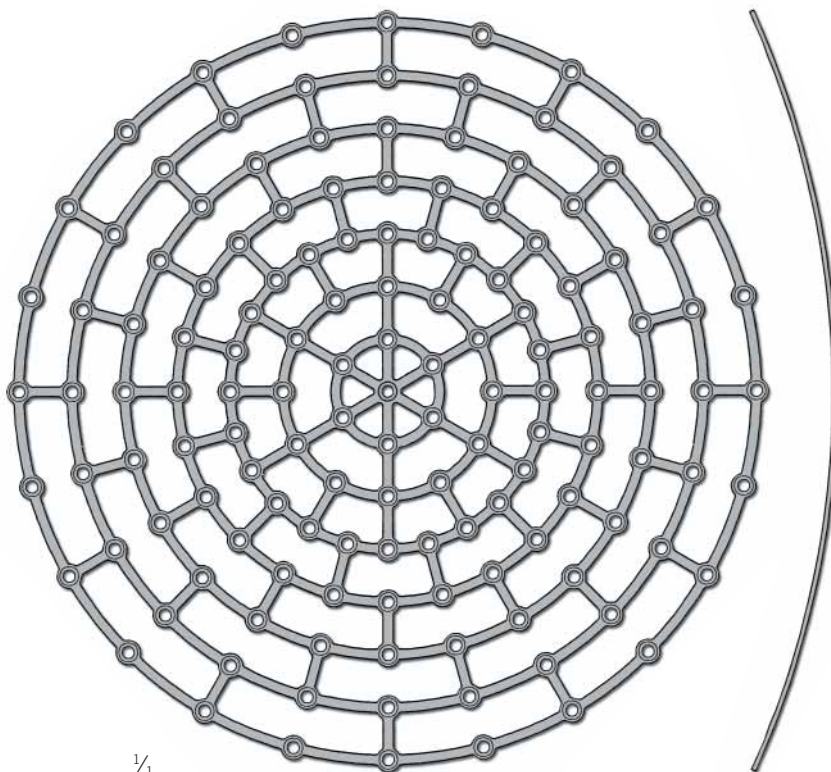

1/4

25-004-90-09

25-004-90-71

Ø = 100 mm

= 0.6 mm



- 25-003-02-09 = 0.3 mm
- 25-003-02-71 = 0.3 mm
- 25-004-02-09 = 0.6 mm
- 25-004-02-71 = 0.6 mm



- 25-015-03-09
- 25-015-03-71
- = 0.6 mm



- 25-015-04-09
- 25-015-04-71
- = 0.6 mm



- 25-015-06-09
- 25-015-06-71
- = 0.6 mm



- 25-015-08-09
- 25-015-08-71
- = 0.6 mm

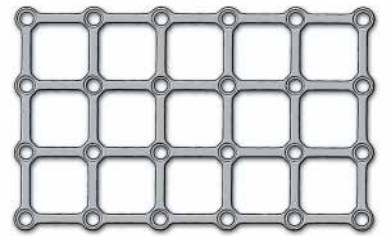

- 25-015-24-09
- 25-015-24-71
- = 0.6 mm



- 25-016-06-09
- 25-016-06-71
- = 0.6 mm



- 25-016-10-09
- 25-016-10-71
- = 0.6 mm



- 25-017-04-09
- 25-017-04-71
- = 0.6 mm

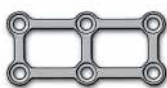

- 25-017-06-09
- 25-017-06-71
- = 0.6 mm

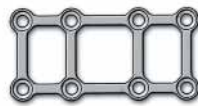

- 25-017-08-09
- 25-017-08-71
- = 0.6 mm

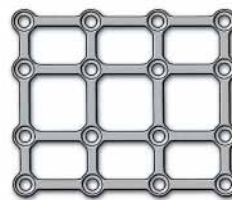

- 25-017-16-09
- 25-017-16-71
- = 0.6 mm

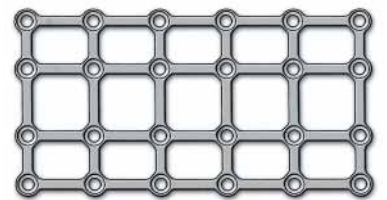

- 25-017-24-09
- 25-017-24-71
- = 0.6 mm

- 25-018-06-09
- 25-018-06-71
- = 1.0 mm

- 25-018-08-09
- 25-018-08-71
- = 1.0 mm

- 25-018-16-09
- 25-018-16-71
- = 1.0 mm

Mikro-Orbita-Mesh

Micro Orbital Mesh
 Micro malla orbital
 Mesh orbitaire Micro
 Mesh Micro orbitale



Platten-Profil
 Plate profile
 Perfil de la placa
 Profil de la plaque
 Profilo placce



Titan
 Titanium
 Titanio
 Titane
 Titano



Verkaufsmenge pro Verpackungseinheit
 Quantity / units per package
 Número de unidades por embalaje
 Nombre d'unités par emballage
 Quantità di vendita per unità d'imballo

STERILE R

Steril verpackte Implantate
 Sterile packed implants
 Implantes embalados de forma estéril
 Implants emballés de manière stérile
 Impianti imballati sterilmente

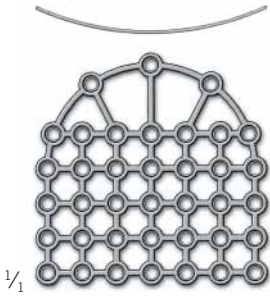

25-042-15-09 = 0.3 mm
 25-042-15-71 = 0.3 mm

Mesh für Orbita-Boden, vorgeformt
 Mesh for orbital floor, contoured
 Malla para la base de la órbita ocular,
 preformada
 Mesh pour fond orbitaire, préformé
 Mesh per il pavimento orbitale,
 preformato

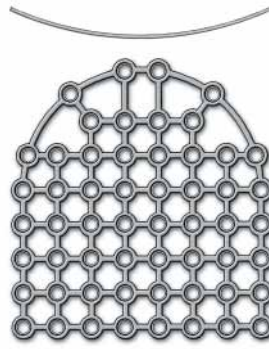

25-042-16-09 = 0.3 mm
 25-042-16-71 = 0.3 mm

Mesh für Orbita-Boden, vorgeformt
 Mesh for orbital floor, contoured
 Malla para la base de la órbita ocular,
 preformada
 Mesh pour fond orbitaire, préformé
 Mesh per il pavimento orbitale,
 preformato

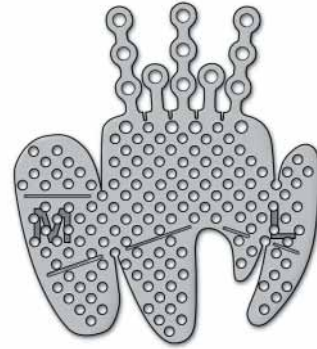

25-043-01-09 = 0.3 mm
 25-043-01-71 = 0.3 mm
 25-043-02-09 = 0.5 mm
 25-043-02-71 = 0.5 mm

Mesh für Orbita-Boden
 Mesh for orbital floor
 Malla para la base de la órbita ocular
 Mesh pour fond orbitaire
 Mesh per il pavimento orbitale

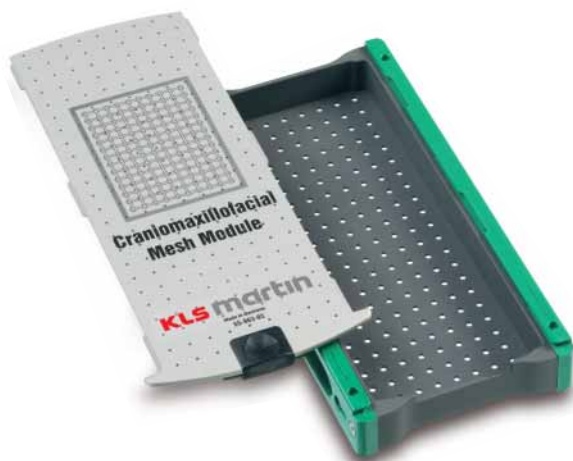

55-962-12-04 Lagerungsmodul ohne Deckel
 Storage module without lid
 Módulo de almacenaje sin tapa
 Module de rangement sans couvercle
 Modulo di supporto senza coperchio

55-963-05-04 Deckel/Lid/Tapa/Couvercle/Coperchio

Bohrlochabdeckplatten 1.5 mm

Burr Hole Covers 1.5 mm
 Placas de recubrimiento de trépano, 1.5 mm
 Plaques de couverture pour trous 1.5 mm
 Placche di copertura per il foro del craniotomo da 1.5 mm

Osteosynthese 1.5 Mikro

Osteosynthesis 1.5 Micro
 Osteosíntesis 1.5 Micro
 Ostéosynthèse 1.5 Micro
 Osteosintesi 1.5 Micro

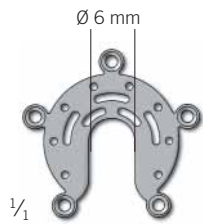
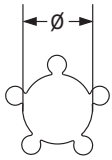

50-310-08-09 Ti 1
 50-310-08-71 Ti 1

Ø 18 mm

flach mit Drainage
 flat with drain
 plano con drenaje
 plat avec drainage
 piano con drenaggio

⊕ = 0.6 mm

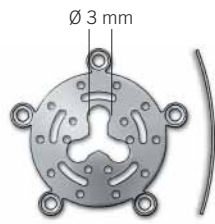

50-310-09-09 Ti 1
 50-310-09-71 Ti 1

Ø 18 mm

vorgeformt mit Drainage
 contoured with drain
 preformado con drenaje
 préformé avec drainage
 preformato con drenaggio

⊕ = 0.6 mm

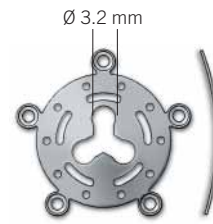

50-310-11-09 Ti 1
 50-310-11-71 Ti 1

Ø 18 mm

vorgeformt mit Drainage
 contoured with drain
 preformado con drenaje
 préformé avec drainage
 preformato con drenaggio

⊕ = 0.6 mm



50-310-12-09 Ti 1
 50-310-12-71 Ti 1

Ø 12 mm

flach
 flat
 plano
 plat
 piano

⊕ = 0.6 mm



50-310-17-09 Ti 1
 50-310-17-71 Ti 1

Ø 17 mm

flach
 flat
 plano
 plat
 piano

⊕ = 0.6 mm



50-310-22-09 Ti 1
 50-310-22-71 Ti 1

Ø 12 mm

vorgeformt
 contoured
 preformado
 préformé
 preformato

⊕ = 0.3 mm



50-310-27-09 Ti 1
 50-310-27-71 Ti 1

Ø 17 mm

vorgeformt
 contoured
 preformado
 préformé
 preformato

⊕ = 0.3 mm



50-310-32-09 Ti 1
 50-310-32-71 Ti 1

Ø 22 mm

vorgeformt
 contoured
 preformado
 préformé
 preformato

⊕ = 0.3 mm

Lindorf-Mikro-Le-Fort-I-Platten und -Kinnplatten

Lindorf Micro Le Fort I Plates and Genioplasty Plates
 Placas Le Fort I y placas para mentón Micro Lindorf
 Plaques Le Fort I et plaques de génioplastie Lindorf Micro
 Placche Lindorf Micro Le Fort I e placche Genioplasty



Platten-Profil
 Plate profile
 Perfil de la placa
 Profil de la plaque
 Profilo placce



Titan
 Titanium
 Titanio
 Titane
 Titanio



Verkaufsmenge pro Verpackungseinheit
 Quantity / units per package
 Número de unidades por embalaje
 Nombre d'unités par emballage
 Quantità di vendita per unità d'imballo

Für Oberkieferververlagerung
 For maxillary process
 Para prolongación del maxilar superior
 Pour apophyse du maxillaire
 Per avanzamenti mascellari



rechts / right / derecha /
 droite / a destra



links / left / izquierda /
 gauche / a sinistra

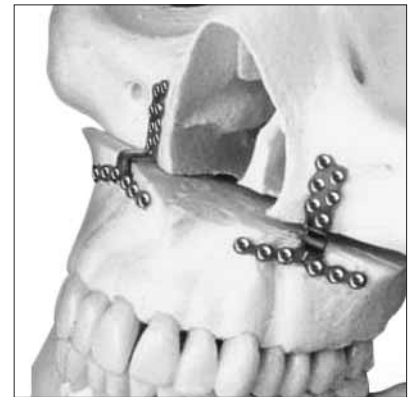

rechts / right / derecha / droite / a destra

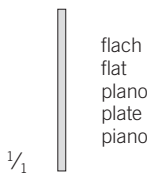

flach
 flat
 plano
 plate
 piano



50-282-03-09 **Ti** 1
 3 mm
 = 1.0 mm



50-282-05-09 **Ti** 1
 5 mm
 = 1.0 mm



50-282-07-09 **Ti** 1
 7 mm
 = 1.0 mm



50-282-09-09 **Ti** 1
 9 mm
 = 1.0 mm



50-282-11-09 **Ti** 1
 11 mm
 = 1.0 mm

links / left / izquierda / gauche / a sinistra

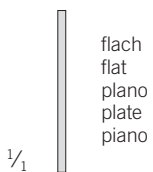

flach
 flat
 plano
 plate
 piano



50-280-03-09 **Ti** 1
 3 mm
 = 1.0 mm



50-280-05-09 **Ti** 1
 5 mm
 = 1.0 mm



50-280-07-09 **Ti** 1
 7 mm
 = 1.0 mm



50-280-09-09 **Ti** 1
 9 mm
 = 1.0 mm



50-280-11-09 **Ti** 1
 11 mm
 = 1.0 mm



Für Kinnplastik
 For genioplasty
 Para genioplastia
 Pour génioplastie
 Per genioplastica

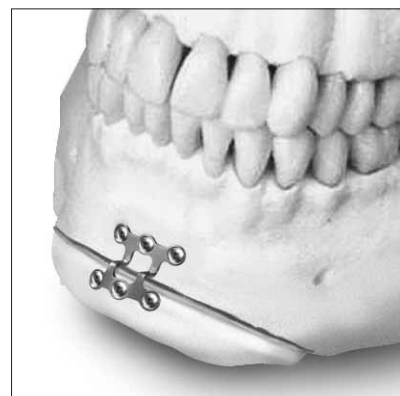

1/1

50-302-01-09 **Ti** 1

1 mm

= 0.6 mm



50-302-03-09 **Ti** 1

3 mm

= 0.6 mm



50-302-05-09 **Ti** 1

5 mm

= 0.6 mm



1/1

50-302-07-09 **Ti** 1

7 mm

= 0.6 mm



50-302-09-09 **Ti** 1

9 mm

= 0.6 mm



50-302-11-09 **Ti** 1

11 mm

= 0.6 mm

Instrumente für 1.5-mm-Mikro-System

Instruments for 1.5 mm Micro System

Instrumental para sistema Micro 1.5 mm

Instruments pour système Micro 1.5 mm

Strumenti per sistema Micro da 1.5 mm

St

Edelstahl
Stainless steel
Acero inoxidable
Acier inoxydable
Acciaio inossidabile

Ti

Titan
Titanium
Titanio
Titane
Titanio

1

Verkaufsmenge pro Verpackungseinheit
Quantity / units per package
Número de unidades por embalaje
Nombre d'unités par emballage
Quantità di vendita per unità d'imballo

TC GOLD

Instrumente mit Hartmetalleinlagen
Instruments with tungsten carbide inserts
Instrumentos con filos de carburo de tungsteno
Instruments avec plaquettes en carbure de tungstène
Strumenti con taglio in carburo di tungsteno



1/2

25-496-15-09 **Ti** **1**

15 cm/6"

Platten-Fasspinzette
Plate-holding forceps
Pinza para sujetar placas
Pince à saisir les plaques
Pinza di presa per placche



1/2

25-441-16-07 **St** **1**

16 cm/6 1/4"

Platten-Fasspinzette
Plate-holding forceps
Pinza para sujetar placas
Pince à saisir les plaques
Pinza di presa per placche

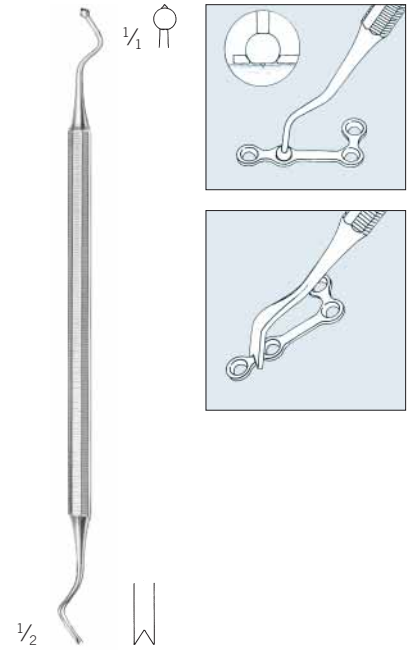

1/2

Lindorf
25-435-15-07 **St** **1**

18 cm/7"

Platten-Halteinstrument
Plate-holding instrument
Instrumento para sujetar placas
Instrument à saisir les plaques
Strumento di presa per placche



1/2

25-412-12-07 **St** **1** **TC GOLD**

12 cm/4 3/4"

Modellierzange
Modeling pliers
Alicates de moldeado
Pince à modeler
Pinza modellante



1/2

25-416-13-07 **St** **1**

13 cm/5 1/4"

Biegezange
Bending pliers
Alicates para doblar
Pince à courber
Pinza piegaplacche



1/2

25-420-16-07 **St** **1** **TC GOLD**

16 cm/6 1/4"

Plattenschneider
Plate cutter
Alicates de corte para placas
Pince à couper les plaques
Taglia placche

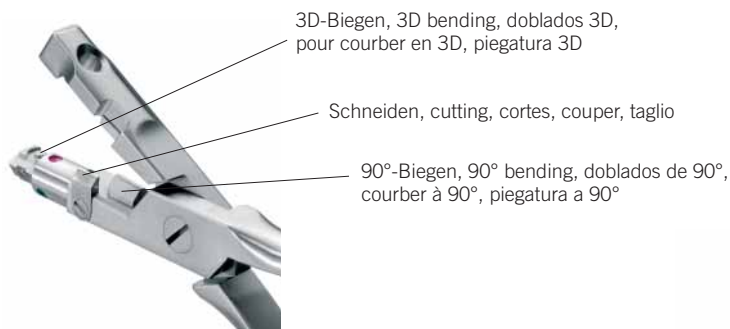

50-502-10-07 **St 1**

16 cm/6 1/4"

Multifunktionszange für die Systeme 1.0/1.5/2.0 mit Funktionen für 3D-Biegen, 90°-Biegen sowie Schneiden

Multifunctional plate bender for 1.0/1.5/2.0 systems for 3D bending, 90° bending, cutting

Alicates multifuncionales para los sistemas 1.0/1.5/2.0 con funciones para doblados 3D, doblados de 90° y cortes

Pince multifonctions pour systèmes 1.0/1.5/2.0 avec fonctions pour courber en 3D, courber à 90°, couper

Pinza multifunzione per i sistemi da 1.0/1.5/2.0 con funzioni di piegatura 3D, piegatura a 90° e taglio

50-502-98-07 **St 1**

Satz Ersatzschneide-Plättchen für 50-502-10-07

Set of spare blades for 50-502-10-07

Juego de cuchillas de recambio para 50-502-10-07

Set de lames de rechange pour 50-502-10-07

Set di lame di ricambio per 50-502-10-07



50-502-11-07 **St 1**

20 cm/8"

Implantate-Schneidezange für die Systeme 1.0/1.5/2.0

Multifunctional plate cutter for 1.0/1.5/2.0 systems

Alicates de corte para implantes previstos para los sistemas 1.0/1.5/2.0

Pince coupante pour implants pour les systèmes 1.0/1.5/2.0

Pinza multifunzione per taglio per sistemi da 1.0/1.5/2.0

50-502-99-07 **St 1**

Satz Ersatzschneide-Plättchen für 50-502-11-07

Set of spare blades for 50-502-11-07

Juego de cuchillas de recambio para 50-502-11-07

Set de lames de rechange pour 50-502-11-07

Set di lame di ricambio per 50-502-11-07

Instrumente für 1.5-mm-Mikro-System

Instruments for 1.5 mm Micro System

Instrumental para sistema Micro 1.5 mm

Instruments pour système Micro 1.5 mm

Strumenti per sistema Micro da 1.5 mm

St

Edelstahl
Stainless steel
Acero inoxidable
Acier inoxydable
Acciaio inossidabile

1

Verkaufsmenge pro Verpackungseinheit
Quantity / units per package
Número de unidades por embalaje
Nombre d'unités par emballage
Quantità di vendita per unità d'imballo

TC GOLD

Instrumente mit Hartmetalleinlagen
Instruments with tungsten carbide inserts
Instrumentos con filos de carburo de tungsteno
Instruments avec plaquettes en carbure de tungstène
Strumenti con taglio in carburo di tungsteno



25-050-00-07 St 1

Mesh-Schneideinstrument
Mesh Cutter
Cortador de malla
Pince à couper le Mesh
Taglia Mesh

25-050-98-07 St 1

Satz Ersatzschneideplättchen
für 25-050-00-07
Set of spare blades for 25-050-00-07
Juego de repuesto de plaquitas de corte
para 25-050-00-07
Set de lames de rechange pour
25-050-00-07
Set di lame da taglio di ricambio
per 25-050-00-07

- ein präzises Mesh-Schneideinstrument mit doppelter Übersetzung
- zur einfachen, patientenspezifischen Anpassung von Mesh-Abschnitten
- zur effektiven und schnellen Anwendung von Mesh-Systemen
- für unser komplettes Mesh-Programm in der
 - kranio-maxillofazialen Traumatologie
 - orthognathischen Chirurgie
 - kraniofazialen Chirurgie
 - rekonstruktiven Chirurgie
 - Neurochirurgie
- schneller und einfacher Wechsel der Schneideplättchen durch den Anwender
- sterilisierbar bei 134 °C

- un instrumento de corte preciso para cortar malla con articulación doble
- para la adaptación sencilla y específica de secciones de malla para cada paciente
- para el uso efectivo y rápido de sistemas de malla
- para nuestra gama completa de malla en la
 - traumatología craneomaxilofacial
 - cirugía ortognática
 - cirugía craneofacial
 - cirugía reconstructiva
 - neurocirugía

- cambio rápido y sencillo de las plaquitas de corte por parte del usuario
- esterilizable a 134 °C

- uno strumento di taglio Mesh di precisione con doppia azione
- per sagomare in modo semplice le Mesh
- per una effettiva e veloce applicazione di sistemi Mesh
- per il nostro programma Mesh completo nella
 - traumatologia cranio-maxillofacciale
 - chirurgia ortognatica
 - chirurgia craniofacciale
 - chirurgia ricostruttiva
 - neurochirurgia
- sostituzione più veloce e più semplice delle lame di taglio da parte dell'utente
- autoclavabile a 134 °C (273 °F)

- a strong and precise double action Mesh Cutter
- for easy creation of Mesh sections in accordance with individual requirements
- for fast and effective application of Mesh systems
- for use with our comprehensive selection of Mesh systems for:
 - craniomaxillofacial trauma
 - orthognathic surgery
 - craniofacial surgery
 - reconstructive surgery
 - neurosurgery
- cutting blades can easily be replaced by the user
- autoclavable at 134 °C (273 °F)

- un instrument à couper le Mesh précis à double action
- pour l'adaptation simple et spécifique au patient de morceaux de Mesh
- pour une utilisation efficace et rapide de systèmes de Mesh
- pour notre gamme complète de Mesh en
 - traumatologie crânio-maxillofaciale
 - chirurgie orthognathique
 - chirurgie crânio-faciale
 - chirurgie reconstructive
 - neurochirurgie
- remplacement rapide et simple des lames de rechange par l'utilisateur
- stérilisable à 134 °C

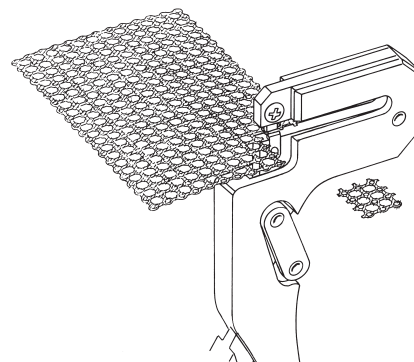



Diese Mesh-Biegezange, versehen mit konvex-konkaven Funktionsteilen, erleichtert das Biegen des Mesh und ermöglicht dadurch eine individuelle anatomische Adaption.

This tool with its convex/concave functional elements makes Mesh bending easy and allows patient-specific anatomical adaptation.

Estos alicates de doblaje para malla, provistos de piezas funcionales convexo-cóncavas, facilitan el doblaje de la malla y, gracias a ello, permiten una adaptación anatómica individual.

Cette pince à courber le Mesh, dotée de pièces fonctionnelles convexes et concaves, facilite la courbure du Mesh et permet donc une adaptation anatomique individuelle.

Questa pinza piegaplacche Mesh, provvista di parti funzionali convesse e concave, facilita la piegatura della rete Mesh e permette così un adattamento anatomico individuale.

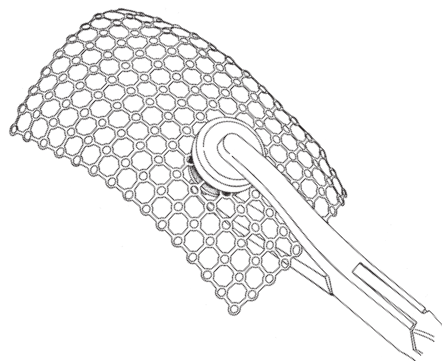

25-052-18-07 St 1
18 cm/7"

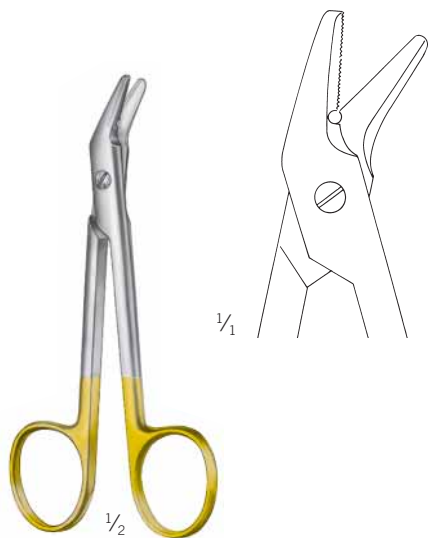

Universal
11-995-12-07 St 1 TC GOLD
12 cm/5"

1.5-mm-Mikro-Modul

1.5 mm Micro Module

Módulo Micro 1.5 mm

Module Micro 1.5 mm

Modulo Micro da 1.5 mm



55-961-02-04

1.5-mm-Mikro-Modul komplett, ohne Implantate
1.5 mm Micro module complete, no implants
Módulo Micro 1.5 mm completo, sin implantes
Module Micro 1.5 mm complet, sans implants
Modulo Micro da 1.5 mm completo, senza gli impianti

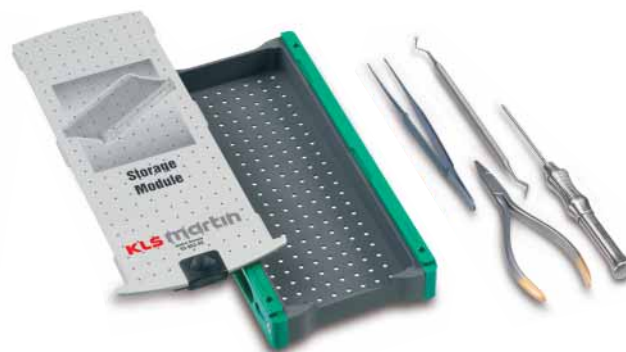

55-962-12-04

1.5-mm-Lagerungsmodul ohne Deckel, ohne Inhalt
1.5 mm storage module without lid, no contents
Módulo de almacenaje 1.5 mm, sin tapa, sin contenido
Module de rangement 1.5 mm sans couvercle, sans contenu
Modulo di supporto da 1.5 mm senza coperchio, senza contenuto

55-963-09-04

Deckel / Lid / Tapa / Couvercle / Coperchio

	<i>1.5-mm-Mikro-Modul</i>	<i>1.5 mm Micro Module</i>	<i>Módulo Micro 1.5 mm</i>
55-961-02-04	1.5-mm-Mikro-Modul komplett bestehend aus:	1.5 mm Micro Module complete consisting of:	Módulo Micro 1.5 mm completo formado por:
55-962-02-04	Insertmodul mit grünen Modulschienen	Insert module, with green side rails	Módulo insertable con guías laterales verdes
55-963-02-04	Deckel für 1.5-mm-Mikro-Modul	Lid for 1.5 mm Micro module	Tapa para módulo Micro 1.5 mm
55-964-02-04	Insert für 1.5 mm Mikro Universal	Insert for 1.5 mm Micro universal	Elemento insertable para Micro 1.5 mm universal
55-964-06-04	Insert für 1.5 mm Mikro Trauma	Insert for 1.5 mm Micro trauma	Elemento insertable para Micro 1.5 mm traumatología
	Das Insert 55-964-02-04 ist vorbereitet für folgende Implantate:	The insert 55-964-02-04 is designed for the following implants:	El elemento insertable 55-964-02-04 está preparado para los siguientes implantes:
25-304-00-09	Mikroplatte, 4-Loch, gerade	Micro plate, 4 holes, straight	Placa Micro, 4 agujeros, recta
25-304-55-09	Mikroplatte, 4-Loch, gerade, kurz	Micro plate, 4 holes, straight, short	Placa Micro, 4 agujeros, recta, corta
25-306-00-09	Mikroplatte, 6-Loch, gerade	Micro plate, 6 holes, straight	Placa Micro, 6 agujeros, recta
25-306-55-09	Mikroplatte, 6-Loch, gerade, kurz	Micro plate, 6 holes, straight, short	Placa Micro, 6 agujeros, recta, corta
25-308-00-09	Mikroplatte, 8-Loch, gerade	Micro plate, 8 holes, straight	Placa Micro, 8 agujeros, recta
25-310-70-09	Mikroplatte, 4-Loch, L-Form, links, mittel	Micro plate, 4 holes, L-shaped, left, medium	Placa Micro, 4 agujeros, forma en L, izquierda, mediana
25-310-85-09	Mikroplatte, 4-Loch, L-Form, links, lang	Micro plate, 4 holes, L-shaped, left, long	Placa Micro, 4 agujeros, forma en L, izquierda, larga
25-311-70-09	Mikroplatte, 4-Loch, L-Form, rechts, mittel	Micro plate, 4 holes, L-shaped, right, medium	Placa Micro, 4 agujeros, forma en L, derecha, mediana
25-311-85-09	Mikroplatte, 4-Loch, L-Form, rechts, lang	Micro plate, 4 holes, L-shaped, right, long	Placa Micro, 4 agujeros, forma en L, derecha, larga
25-314-85-09	Mikroplatte, 5-Loch, L-Form, links, lang, 100°	Micro plate, 5 holes, L-shaped, left, long, 100°	Placa Micro, 5 agujeros, forma en L, izquierda, larga, 100°
25-315-06-09	Mikroplatte, 6-Loch, T-Form	Micro plate, 6 holes, T-shaped	Placa Micro, 6 agujeros, forma en T
25-315-85-09	Mikroplatte, 5-Loch, L-Form, rechts, lang, 100°	Micro plate, 5 holes, L-shaped, right, long, 100°	Placa Micro, 5 agujeros, forma en L, derecha, larga, 100°
25-316-00-09	Mikroplatte, 16-Loch, gerade	Micro plate, 16 holes, straight	Placa Micro, 16 agujeros, recta
25-320-70-09	Mikroplatte, 5-Loch, Y-Form, mittel	Micro plate, 5 holes, Y-shaped, medium	Placa Micro, 5 agujeros, forma en Y, mediana
25-322-55-09	Mikroplatte, 6-Loch, Doppel-Y-Form, kurz	Micro plate, 6 holes, double Y-shaped, short	Placa Micro, 6 agujeros, forma en Y doble, corta
25-326-55-09	Mikroplatte, 4-Loch, Kreuz-Form	Micro plate, 4 holes, cross-shaped	Placa Micro, 4 agujeros, forma en cruz
	Das Insert 55-964-06-04 ist vorbereitet für folgende Implantate:	The insert 55-964-06-04 is designed for the following implants:	El elemento insertable 55-964-06-04 está preparado para los siguientes implantes:
25-325-10-09	Mikroplatte, 10-Loch, gebogen	Micro plate, 10 holes, curved	Placa Micro, 10 agujeros, doblada
25-329-05-09	Mikroplatte, 6-Loch, Y-Form	Micro plate, 6 holes, Y-shaped	Placa Micro, 6 agujeros, forma en Y
25-330-05-09	Mikroplatte, 7-Loch, L-Form, links	Micro plate, 7 holes, L-shaped, left	Placa Micro, 7 agujeros, forma en L, izquierda
25-330-07-09	Mikroplatte, 6-Loch, T-Form	Micro plate, 6 holes, T-shaped	Placa Micro, 6 agujeros, forma en T
25-330-24-09	Mikroplatte, 24-Loch, gerade	Micro plate, 24 holes, straight	Placa Micro, 24 agujeros, recta
25-330-85-09	Mikroplatte, 6-Loch, L-Form, links	Micro plate, 6 holes, L-shaped, left	Placa Micro, 6 agujeros, forma en L, izquierda
25-331-05-09	Mikroplatte, 7-Loch, L-Form, rechts	Micro plate, 7 holes, L-shaped, right	Placa Micro, 7 agujeros, forma en L, derecha
25-331-85-09	Mikroplatte, 6-Loch, L-Form, rechts	Micro plate, 6 holes, L-shaped, right	Placa Micro, 6 agujeros, forma en L, derecha

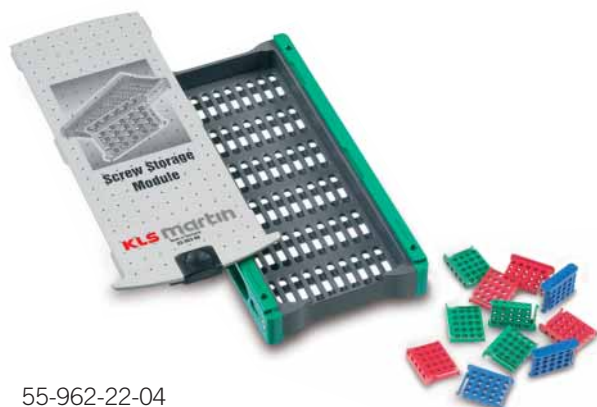

55-962-22-04

1.5-mm-Schrauben-Lagerungsmodul ohne Deckel
 1.5 mm screw storage module without lid
 Módulo de almacenaje para tornillos 1.5 mm sin tapa
 Module de rangement pour vis 1.5 mm sans couvercle
 Modulo supporto viti da 1.5 mm senza coperchio



55-962-32-04

Doppel-Insertmodul
 Twin insert module
 Módulo de inserción doble
 Module inserts double
 Modulo inserto doppio

55-963-08-04

Deckel / Lid / Tapa / Couvercle / Coperchio

<i>Module Micro 1.5 mm</i>		<i>Modulo Micro da 1.5 mm</i>	
55-961-02-04	Module Micro 1.5 mm complet composé de:	Modulo Micro da 1.5 mm completo consistente in:	
55-962-02-04	Module inserts avec rails de module verts	Modulo di inserimento con rotaie modulari verdi	
55-963-02-04	Couvercle pour module Micro 1.5 mm	Coperchio per modulo Micro da 1.5 mm	
55-964-02-04	Insert pour Micro 1.5 mm universel	Inserto per Micro da 1.5 mm universale	
55-964-06-04	Insert traumatique pour Micro 1.5 mm	Inserto per Micro da 1.5 mm trauma	
	L'insert 55-964-02-04 est conçu pour les implants suivants:	L'inserto 55-964-02-04 è progettato per i seguenti impianti:	
25-304-00-09	Plaque Micro, 4 trous, droite	Placca Micro, 4 fori, diritta	
25-304-55-09	Plaque Micro, 4 trous, droite, courte	Placca Micro, 4 fori, diritta, corta	
25-306-00-09	Plaque Micro, 6 trous, droite	Placca Micro, 6 fori, diritta	
25-306-55-09	Plaque Micro, 6 trous, droite, courte	Placca Micro, 6 fori, diritta, corta	
25-308-00-09	Plaque Micro, 8 trous, droite	Placca Micro, 8 fori, diritta	
25-310-70-09	Plaque Micro, 4 trous, en L, à gauche, moyenne	Placca Micro, 4 fori, forma a L, a sinistra, media	
25-310-85-09	Plaque Micro, 4 trous, en L, à gauche, longue	Placca Micro, 4 fori, forma a L, a sinistra, lunga	
25-311-70-09	Plaque Micro, 4 trous, en L, à droite, moyenne	Placca Micro, 4 fori, forma a L, a destra, media	
25-311-85-09	Plaque Micro, 4 trous, en L, à droite, longue	Placca Micro, 4 fori, forma a L, a destra, lunga	
25-314-85-09	Plaque Micro, 5 trous, en L, à gauche, longue, 100°	Placca Micro, 5 fori, forma a L, a sinistra, lunga, 100°	
25-315-06-09	Plaque Micro, 6 trous, en T	Placca Micro, 6 fori, forma a T	
25-315-85-09	Plaque Micro, 5 trous, en L, à droite, longue, 100°	Placca Micro, 5 fori, forma a L, a destra, lunga, 100°	
25-316-00-09	Plaque Micro, 16 trous, droite	Placca Micro, 16 fori, diritta	
25-320-70-09	Plaque Micro, 5 trous en Y, moyenne	Placca Micro, 5 fori, forma a Y, media	
25-322-55-09	Plaque Micro, 6 trous, en double Y, courte	Placca Micro, 6 fori, forma a doppia Y, corta	
25-326-55-09	Plaque Micro, 4 trous, en croix	Placca Micro, 4 fori, forma a croce	
	L'insert 55-964-06-04 est conçu pour les implants suivants:	L'inserto 55-964-06-04 è progettato per i seguenti impianti:	
25-325-10-09	Plaque Micro, 10 trous, courbe	Placca Micro, 10 fori, curva	
25-329-05-09	Plaque Micro, 6 trous, en Y	Placca Micro, 6 fori, forma a Y	
25-330-05-09	Plaque Micro, 7 trous, en L, à gauche	Placca Micro, 7 fori, forma a L, a sinistra	
25-330-07-09	Plaque Micro, 6 trous, en T	Placca Micro, 6 fori, forma a T	
25-330-24-09	Plaque Micro, 24 trous, droite	Placca Micro, 24 fori, diritta	
25-330-85-09	Plaque Micro, 6 trous, en L, à gauche	Placca Micro, 6 fori, forma a L, a sinistra	
25-331-05-09	Plaque Micro, 7 trous, en L, à droite	Placca Micro, 7 fori, forma a L, a destra	
25-331-85-09	Plaque Micro, 6 trous, en L, à droite	Placca Micro, 6 fori, forma a L, a destra	

1.5-mm-Neurochirurgie-Modul

1.5 mm Neurosurgery Module

Módulo de neurocirugía 1.5 mm

Module de neurochirurgie 1.5 mm

Modulo per neurochirurgia da 1.5 mm



55-961-04-04

1.5-mm-Neurochirurgie-Modul komplett, ohne Implantate
 1.5 mm Neurosurgery Module complete, no implants
 Módulo de neurocirugía 1.5 mm completo, sin implantes
 Module de neurochirurgie 1.5 mm complet, sans implants
 Modulo per neurochirurgia da 1.5 mm completo, senza gli impianti

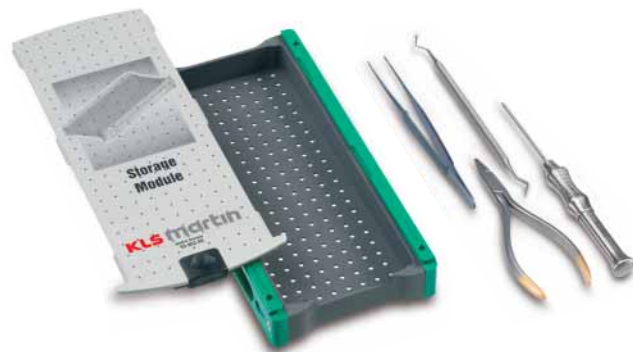

55-962-12-04

1.5-mm-Lagerungsmodul ohne Deckel, ohne Inhalt
 1.5 mm storage module without lid, no contents
 Módulo de almacenaje 1.5 mm, sin tapa, sin contenido
 Module de rangement 1.5 mm sans couvercle, sans contenu
 Modulo di supporto da 1.5 mm senza coperchio, senza contenuto

55-963-09-04

Deckel / Lid / Tapa / Couvercle / Coperchio

	<i>1.5-mm-Neurochirurgie-Modul</i>	<i>1.5 mm Neurosurgery Module</i>	<i>Módulo de neurocirugía 1.5 mm</i>
55-961-04-04	1.5-mm-Neurochirurgie-Modul komplett bestehend aus:	1.5 mm Neurosurgery Module complete consisting of:	Módulo de neurocirugía 1.5 mm completo formado por:
55-962-02-04	Insertmodul mit grünen Modulschienen	Insert module, with green side rails	Módulo insertable con guías laterales verdes
55-963-04-04	Deckel für 1.5-mm-Neurochirurgie-Modul	Lid for 1.5 mm neurosurgery module	Tapa para 1.5 mm módulo de neurocirugía
55-964-04-04	Insert für 1.5-mm-Neurochirurgie-Modul	Insert for 1.5 mm neurosurgery module	Elemento insertable para Módulo de neurocirugía 1.5 mm
55-964-17-04	Insert Universal	Insert, universal	Elemento insertable universal
	Das Insert 55-964-04-04 ist vorbereitet für folgende Implantate:	The insert 55-964-04-04 is designed for the following implants:	El elemento insertable 55-964-04-04 está preparado para los siguientes implantes:
25-015-04-09	Mikro-Mesh 2 x 2-Loch	Micro mesh, 2 x 2 holes	Micro malla, 2 x 2 agujeros
25-015-06-09	Mikro-Mesh 3 x 2-Loch	Micro mesh, 3 x 2 holes	Micro malla, 3 x 2 agujeros
25-015-08-09	Mikro-Mesh 4 x 2-Loch	Micro mesh, 4 x 2 holes	Micro malla, 4 x 2 agujeros
25-016-06-09	Mikro-Mesh 3 x 2-Loch	Micro mesh, 3 x 2 holes	Micro malla, 3 x 2 agujeros
25-016-10-09	Mikro-Mesh 5 x 2-Loch	Micro mesh, 5 x 2 holes	Micro malla, 5 x 2 agujeros
25-302-12-09	Mikroplatte, 2-Loch, gerade	Micro plate, 2 holes, straight	Placa Micro, 2 agujeros, recta
25-302-70-09	Mikroplatte, 2-Loch, gerade	Micro plate, 2 holes, straight	Placa Micro, 2 agujeros, recta
25-304-00-09	Mikroplatte, 4-Loch, gerade	Micro plate, 4 holes, straight	Placa Micro, 4 agujeros, recta
25-304-85-09	Mikroplatte, 4-Loch, gerade, lang	Micro plate, 4 holes, straight, long	Placa Micro, 4 agujeros, recta, larga
25-316-00-09	Mikroplatte, 16-Loch, gerade	Micro plate, 16 holes, straight	Placa Micro, 16 agujeros, recta
25-320-70-09	Mikroplatte, 5-Loch, Y-Form, mittel	Micro plate, 5 holes, Y-shaped, medium	Placa Micro, 5 agujeros, forma en Y, mediana
25-322-70-09	Mikroplatte, 6-Loch, Doppel-Y-Form, mittel	Micro plate, 6 holes, double-Y-shaped, medium	Placa Micro, 6 agujeros, forma en Y doble, mediana
50-310-22-09	Burr Hole Cover, 12 mm	Burr hole cover, 12 mm	Placa de recubrimiento de trépano, 12 mm
50-310-27-09	Burr Hole Cover, 17 mm	Burr hole cover, 17 mm	Placa de recubrimiento de trépano, 17 mm



55-962-22-04

1.5-mm-Schrauben-Lagerungsmodul ohne Deckel
1.5 mm screw storage module without lid
Módulo de almacenaje para tornillos 1.5 mm sin tapa
Module de rangement pour vis 1.5 mm sans couvercle
Modulo supporto viti da 1.5 mm senza coperchio



55-962-32-04

Doppel-Insertmodul
Twin insert module
Módulo de inserción doble
Module inserts double
Modulo inserto doppio

55-963-08-04

Deckel / Lid / Tapa / Couvercle / Coperchio

	<i>Module de neurochirurgie 1.5 mm</i>	<i>Modulo per neurochirurgia da 1.5 mm</i>
55-961-04-04	Module de neurochirurgie 1.5 mm complet composé de:	Modulo per neurochirurgia da 1.5 mm completo consistente in:
55-962-02-04	Module inserts avec rails de module verts	Modulo di inserimento con rotaie modulari verdi
55-963-04-04	Couvercle pour module de neurochirurgie 1.5 mm	Coperchio per modulo per neurochirurgia da 1.5 mm
55-964-04-04	Insert pour module de neurochirurgie 1.5 mm	Inserto per modulo per neurochirurgia da 1.5 mm
55-964-17-04	Insert universel	Inserto universale
	L'insert 55-964-04-04 est conçu pour les implants suivants:	L'inserto 55-964-04-04 è progettato per i seguenti impianti:
25-015-04-09	Mesh Micro 2 x 2 trous	Mesh Micro, 2 x 2 fori
25-015-06-09	Mesh Micro 3 x 2 trous	Mesh Micro, 3 x 2 fori
25-015-08-09	Mesh Micro 4 x 2 trous	Mesh Micro, 4 x 2 fori
25-016-06-09	Mesh Micro 3 x 2 trous	Mesh Micro, 3 x 2 fori
25-016-10-09	Mesh Micro 5 x 2 trous	Mesh Micro, 5 x 2 fori
25-302-12-09	Plaque Micro, 2 trous, droite	Placca Micro, 2 fori, diritta
25-302-70-09	Plaque Micro, 2 trous, droite	Placca Micro, 2 fori, diritta
25-304-00-09	Plaque Micro, 4 trous, droite	Placca Micro, 4 fori, diritta
25-304-85-09	Plaque Micro, 4 trous, droite, longue	Placca Micro, 4 fori, diritta, lunga
25-316-00-09	Plaque Micro, 16 trous, droite	Placca Micro, 16 fori, diritta
25-320-70-09	Plaque Micro, 5 trous, en Y, moyenne	Placca Micro, 5 fori, forma a Y, media
25-322-70-09	Plaque Micro, 6 trous, en double Y, moyenne	Placca Micro, 6 fori, forma a doppia Y, media
50-310-22-09	Plaque de couverture pour trou, 12 mm	Coperchio per foro trapanato, 12 mm
50-310-27-09	Plaque de couverture pour trou, 17 mm	Coperchio per foro trapanato, 17 mm

1.5-mm-Lindorf-Orthognathie-Modul

1.5 mm Lindorf Orthognathic Module

Módulo ortognático Lindorf 1.5 mm

Module d'orthognathie Lindorf 1.5 mm

Modulo ortognatico Lindorf da 1.5 mm



55-961-03-04

1.5-mm-Lindorf-Orthognathie-Modul komplett, ohne Implantate
1.5 mm Lindorf Orthognathic Module complete, no implants
Módulo ortognático Lindorf 1.5 mm completo, sin implantes
Module d'orthognathie Lindorf 1.5 mm complet, sans implants
Modulo ortognatico Lindorf da 1.5 mm completo, senza gli impianti

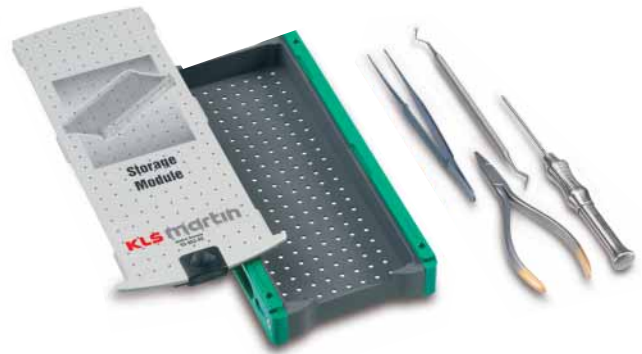

55-962-12-04

1.5-mm-Lagerungsmodul ohne Deckel, ohne Inhalt
1.5 mm storage module without lid, no contents
Módulo de almacenaje 1.5 mm, sin tapa, sin contenido
Module de rangement 1.5 mm sans couvercle, sans contenu
Modulo di supporto da 1.5 mm senza coperchio, senza contenuto

55-963-09-04

Deckel / Lid / Tapa / Couvercle / Coperchio

	<i>1.5-mm-Lindorf-Orthognathie-Modul</i>	<i>1.5 mm Lindorf Orthognathic Module</i>	<i>Módulo ortognático Lindorf 1.5 mm</i>
55-961-03-04	1.5-mm-Lindorf-Orthognathie-Modul komplett bestehend aus:	1.5 mm Lindorf Orthognathic Module complete consisting of:	Módulo ortognático Lindorf 1.5 mm completo formado por:
55-962-02-04	Insertmodul mit grünen Modulschienen	Insert module, with green side rails	Módulo insertable con guías laterales verdes
55-963-03-04	Deckel für 1.5-mm-Lindorf-Orthognathie-Modul	Lid for 1.5 mm Lindorf orthognathic module	Tapa para módulo ortognático Lindorf 1.5 mm
55-964-11-04	Insert 1 für 1.5-mm-Lindorf-Orthognathie-Modul	Insert 1 for 1.5 mm Lindorf orthognathic module	Elemento insertable 1 para módulo ortognático Lindorf 1.5 mm
55-964-12-04	Insert 2 für 1.5-mm-Lindorf-Orthognathie-Modul	Insert 2 for 1.5 mm Lindorf orthognathic module	Elemento insertable 2 para módulo ortognático Lindorf 1.5 mm
	Das Insert 55-964-11-04 ist vorbereitet für folgende Implantate:	The insert 55-964-11-04 is designed for the following implants:	El elemento insertable 55-964-11-04 está preparado para los siguientes implantes:
50-280-00-09	Lindorf-Platte, 0 mm, links	Lindorf plate, 0 mm, left	Placa Lindorf, 0 mm, izquierda
50-280-03-09	Lindorf-Platte, 3 mm, links	Lindorf plate, 3 mm, left	Placa Lindorf, 3 mm, izquierda
50-280-05-09	Lindorf-Platte, 5 mm, links	Lindorf plate, 5 mm, left	Placa Lindorf, 5 mm, izquierda
50-282-00-09	Lindorf-Platte, 0 mm, rechts	Lindorf plate, 0 mm, right	Placa Lindorf, 0 mm, derecha
50-282-03-09	Lindorf-Platte, 3 mm, rechts	Lindorf plate, 3 mm, right	Placa Lindorf, 3 mm, derecha
50-282-05-09	Lindorf-Platte, 5 mm, rechts	Lindorf plate, 5 mm, right	Placa Lindorf, 5 mm, derecha
50-302-01-09	Lindorf-Kinnplatte, 1 mm	Lindorf chin plate, 1 mm	Placa para mentón Lindorf, 1 mm
50-302-03-09	Lindorf-Kinnplatte, 3 mm	Lindorf chin plate, 3 mm	Placa para mentón Lindorf, 3 mm
50-302-05-09	Lindorf-Kinnplatte, 5 mm	Lindorf chin plate, 5 mm	Placa para mentón Lindorf, 5 mm
	Das Insert 55-964-12-04 ist vorbereitet für folgende Implantate:	The insert 55-964-12-04 is designed for the following implants:	El elemento insertable 55-964-12-04 está preparado para los siguientes implantes:
50-280-07-09	Lindorf-Platte, 7 mm, links	Lindorf plate, 7 mm, left	Placa Lindorf, 7 mm, izquierda
50-280-09-09	Lindorf-Platte, 9 mm, links	Lindorf plate, 9 mm, left	Placa Lindorf, 9 mm, izquierda
50-280-11-09	Lindorf-Platte, 11 mm, links	Lindorf plate, 11 mm, left	Placa Lindorf, 11 mm, izquierda
50-282-07-09	Lindorf-Platte, 7 mm, rechts	Lindorf plate, 7 mm, right	Placa Lindorf, 7 mm, derecha
50-282-09-09	Lindorf-Platte, 9 mm, rechts	Lindorf plate, 9 mm, right	Placa Lindorf, 9 mm, derecha
50-282-11-09	Lindorf-Platte, 11 mm, rechts	Lindorf plate, 11 mm, right	Placa Lindorf, 11 mm, derecha
50-302-07-09	Lindorf-Kinnplatte, 7 mm	Lindorf chin plate, 7 mm	Placa para mentón Lindorf, 7 mm
50-302-09-09	Lindorf-Kinnplatte, 9 mm	Lindorf chin plate, 9 mm	Placa para mentón Lindorf, 9 mm
50-302-11-09	Lindorf-Kinnplatte, 11 mm	Lindorf chin plate, 11 mm	Placa para mentón Lindorf, 11 mm



55-962-22-04

1.5-mm-Schrauben-Lagerungsmodul ohne Deckel
1.5 mm screw storage module without lid
Módulo de almacenaje para tornillos 1.5 mm sin tapa
Module de rangement pour vis 1.5 mm sans couvercle
Modulo supporto viti da 1.5 mm senza coperchio



55-962-32-04

Doppel-Insertmodul
Twin insert module
Módulo de inserción doble
Module inserts double
Modulo inserto doppio

55-963-08-04

Deckel / Lid / Tapa / Couvercle / Coperchio

<i>Module d'orthognathie Lindorf 1.5 mm</i>		<i>Modulo ortognatico Lindorf da 1.5 mm</i>	
55-961-03-04	Module d'orthognathie Lindorf 1.5 mm complet composé de:	Modulo ortognatico Lindorf da 1.5 mm completo consistente in:	
55-962-02-04	Module inserts avec rails de module verts	Modulo di inserimento con rotaie modulari verdi	
55-963-03-04	Couvercle pour module d'orthognathie Lindorf 1.5 mm	Coperchio per modulo ortognatico Lindorf da 1.5 mm	
55-964-11-04	Insert 1 pour module d'orthognathie Lindorf 1.5 mm	Inserto 1 per modulo ortognatico Lindorf da 1.5 mm	
55-964-12-04	Insert 2 pour module d'orthognathie Lindorf 1.5 mm	Inserto 2 per modulo ortognatico Lindorf da 1.5 mm	
	L'insert 55-964-11-04 est conçu pour les implants suivants:	L'inserto 55-964-11-04 è progettato per i seguenti impianti:	
50-280-00-09	Plaque Lindorf, 0 mm, à gauche	Placca Lindorf, 0 mm, a sinistra	
50-280-03-09	Plaque Lindorf, 3 mm, à gauche	Placca Lindorf, 3 mm, a sinistra	
50-280-05-09	Plaque Lindorf, 5 mm, à gauche	Placca Lindorf, 5 mm, a sinistra	
50-282-00-09	Plaque Lindorf, 0 mm, à droite	Placca Lindorf, 0 mm, a destra	
50-282-03-09	Plaque Lindorf, 3 mm, à droite	Placca Lindorf, 3 mm, a destra	
50-282-05-09	Plaque Lindorf, 5 mm, à droite	Placca Lindorf, 5 mm, a destra	
50-302-01-09	Plaque pour menton Lindorf, 1 mm	Placca per il mento Lindorf, 1 mm	
50-302-03-09	Plaque pour menton Lindorf, 3 mm	Placca per il mento Lindorf, 3 mm	
50-302-05-09	Plaque pour menton Lindorf, 5 mm	Placca per il mento Lindorf, 5 mm	
	L'insert 55-964-12-04 est conçu pour les implants suivants:	L'inserto 55-964-12-04 è progettato per i seguenti impianti:	
50-280-07-09	Plaque Lindorf, 7 mm, à gauche	Placca Lindorf, 7 mm, a sinistra	
50-280-09-09	Plaque Lindorf, 9 mm, à gauche	Placca Lindorf, 9 mm, a sinistra	
50-280-11-09	Plaque Lindorf, 11 mm, à gauche	Placca Lindorf, 11 mm, a sinistra	
50-282-07-09	Plaque Lindorf, 7 mm, à droite	Placca Lindorf, 7 mm, a destra	
50-282-09-09	Plaque Lindorf, 9 mm, à droite	Placca Lindorf, 9 mm, a destra	
50-282-11-09	Plaque Lindorf, 11 mm, à droite	Placca Lindorf, 11 mm, a destra	
50-302-07-09	Plaque pour menton Lindorf, 7 mm	Placca per il mento Lindorf, 7 mm	
50-302-09-09	Plaque pour menton Lindorf, 9 mm	Placca per il mento Lindorf, 9 mm	
50-302-11-09	Plaque pour menton Lindorf, 11 mm	Placca per il mento Lindorf, 11 mm	

Instrumentenlagerung

Instrument Trays
Bandejas para instrumentos
Rangement des instruments
Supporti per strumenti

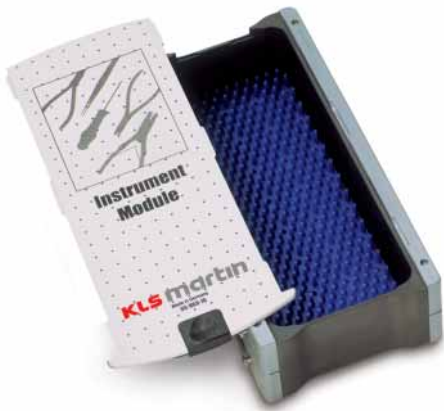

55-969-16-04

Frei-Lagerung, mit Deckel, ohne Silikonmatte
Free storage, with lid, no silicone mat
Almacenaje libre, con tapa, sin alfombra de silicona
Rangement libre, avec couvercle, sans tapis de silicone
Supporto solo, con coperchio, senza tappetino in silicone



55-969-26-04

Multi-Lagerung*, konfiguriert, mit Deckel, ohne Instrumente
Multi storage*, preconfigured, with lid, no instruments
Almacenaje multi*, preconfigurado, con tapa, sin instrumentos
Rangement multi*, configuré, avec couvercle, sans instruments
Supporto multi*, preconfigurato, con coperchio, senza strumenti

		<i>Instrumentenmodule</i>	<i>Instrument modules</i>	<i>Módulos para instrumentos</i>
55-969-16-04	15 x 30 cm	Frei-Lagerung, mit Deckel	Free storage, with lid	Almacenaje libre, con tapa
55-969-14-04	30 x 30 cm	Frei-Lagerung, mit Deckel	Free storage, with lid	Almacenaje libre, con tapa
55-969-26-04	15 x 30 cm	Multi*, konfiguriert, mit Deckel	Multi*, preconfigured, with lid	Multi*, preconfigurado, con tapa
55-969-57-04	15 x 30 cm	Basic*, konfiguriert, mit Deckel	Basic*, preconfigured, with lid	Basic*, preconfigurado, con tapa
		Einzelkomponenten	Individual components	Componentes individuales
55-964-15-04	15 x 30 cm	Frei-Lagerung, ohne Deckel	Free storage, w/o lid	Almacenaje libre, sin tapa
55-964-30-04	30 x 30 cm	Frei-Lagerung, ohne Deckel	Free storage, w/o lid	Almacenaje libre, sin tapa
55-969-15-04	15 x 30 cm	Multi*, konfiguriert, ohne Deckel	Multi*, preconfigured, w/o lid	Multi*, preconfigurado, sin tapa
55-969-47-04	15 x 30 cm	Basic*, konfiguriert, ohne Deckel	Basic*, preconfigured, w/o lid	Basic*, preconfigurado, sin tapa
55-963-15-04	15 x 30 cm	Deckel multi	Lid multi	Tapa múltiple
55-963-16-04	15 x 30 cm	Deckel basic	Lid basic	Tapa basic
55-963-30-04	30 x 30 cm	Deckel	Lid	Tapa
55-969-94-04	15 x 30 cm	Silikonmatte für 55-969-16-04	Silicone mat for 55-969-16-04	Alfombrilla de silicona para 55-969-16-04
55-969-93-04	30 x 30 cm	Silikonmatte für 55-969-14-04	Silicone mat for 55-969-14-04	Alfombrilla de silicona para 55-969-14-04
		Modulclips	Module Clips	Clips para módulos
55-969-98-04		für Aufnahme von 3 Racks, links	Module clip for 3 racks, left	para la recepción de 3 módulos, izquierda
55-969-99-04		für Aufnahme von 3 Racks, rechts	Module clip for 3 racks, right	para la recepción de 3 módulos, derecha
55-969-96-04		für Aufnahme von 4 Racks, links	Module clip for 4 racks, left	para la recepción de 4 módulos, izquierda
55-969-97-04		für Aufnahme von 4 Racks, rechts	Module clip for 4 racks, right	para la recepción de 4 módulos, derecha

* Multi = Lagerung vorbereitet für LEVEL-ONE-Multifunktionsinstrumente

* Basic = Lagerung vorbereitet für traditionelle Instrumente

siehe Seite 36

* Multi = Module prepared for LEVEL ONE multifunction instruments

* Basic = Module prepared for conventional instruments

see page 36

* Multi = Almacenaje preparado para instrumentos multifuncionales LEVEL ONE

* Basic = Almacenaje preparado para instrumentos tradicionales

consulte la página 36



55-969-57-04

Basic-Lagerung*, konfiguriert, mit Deckel, ohne Instrumente
 Basic storage*, preconfigured, with lid, no instruments
 Almacenaje basic*, preconfigurado, con tapa, sin instrumentos
 Rangement basic*, configuré, avec couvercle, sans instruments
 Supporto basic*, preconfigurato, con coperchio, senza strumenti

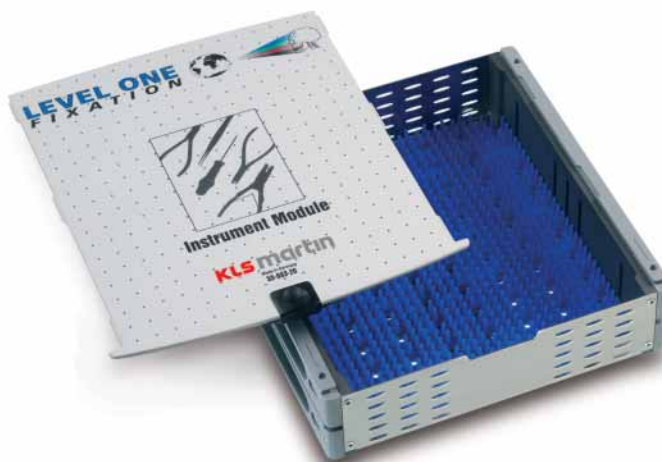

55-969-14-04

Frei-Lagerung, mit Deckel, ohne Silikonmatte
 Free storage, with lid, no silicone mat
 Almacenaje libre, con tapa, sin alfombra de silicona
 Rangement libre, avec couvercle, sans tapis de silicone
 Supporto solo, con coperchio, senza tappetino in silicone

<i>Modules pour instruments</i>			<i>Moduli per strumenti</i>		
55-969-16-04	15 x 30 cm	Rangement libre, avec couvercle	Supporto solo, con coperchio		
55-969-14-04	30 x 30 cm	Rangement libre, avec couvercle	Supporto solo, con coperchio		
55-969-26-04	15 x 30 cm	Multi*, configuré, avec couvercle	Multi*, preconfigurato, con coperchio		
55-969-57-04	15 x 30 cm	Basic*, configuré, avec couvercle	Basic*, preconfigurato, con coperchio		
		Éléments individuels			Componenti singoli
55-964-15-04	15 x 30 cm	Rangement libre, sans couvercle	Supporto solo, senza coperchio		
55-964-30-04	30 x 30 cm	Rangement libre, sans couvercle	Supporto solo, senza coperchio		
55-969-15-04	15 x 30 cm	Multi*, configuré, sans couvercle	Multi*, preconfigurato, senza coperchio		
55-969-47-04	15 x 30 cm	Basic*, configuré, sans couvercle	Basic*, preconfigurato, senza coperchio		
55-963-15-04	15 x 30 cm	Couvercle multi	Coperchio Multi		
55-963-16-04	15 x 30 cm	Couvercle basic	Coperchio basic		
55-963-30-04	30 x 30 cm	Couvercle	Coperchio		
55-969-94-04	15 x 30 cm	Tapis en silicone pour 55-969-16-04	Tappetino in silicone per 55-969-16-04		
55-969-93-04	30 x 30 cm	Tapis en silicone pour 55-969-14-04	Tappetino in silicone per 55-969-14-04		
		Clips pour modules			Clip per moduli
55-969-98-04		pour loger 3 boîtes, gauche	Clip per moduli con 3 rack, a sinistra		
55-969-99-04		pour loger 3 boîtes, droit	Clip per moduli con 3 rack, a destra		
55-969-96-04		pour loger 4 boîtes, gauche	Clip per moduli con 4 rack, a sinistra		
55-969-97-04		pour loger 4 boîtes, droit	Clip per moduli con 4 rack, a destra		

* Multi = préparation pour le rangement d'instruments multifonctions LEVEL ONE

* Basic = préparation pour le rangement d'instruments traditionnels

voir page 36

* Multi = Modulo preparato gli strumenti multifunzione LEVEL ONE

* Basic = Modulo preparato per strumenti convenzionali



vedi pagina 36

Setvorschläge

Set Recommendations
 Recomendaciones de set
 Sets recommandés
 Suggestimenti per composizioni

1

Empfohlene Stückzahl
 Recommended quantity
 Cantidad recomendada
 Quantité recommandée
 Quantità raccomandate

		Setvorschläge	Set Recommendations
	55-969-26-04	Instrumententray Multi, konfiguriert 15 x 30 cm vorbereitet für:	Instrument tray, multi, preconfigured 15 x 30 cm prepared for:
	25-402-99-07	② Schraubendreherhandgriff, mittel	Screwdriver handle, medium
	25-406-99-07	② Schraubendreherhandgriff, groß	Screwdriver handle, large
	25-435-10-07	① Lindorf-Plattenhalte-Instrument 1.0 mm	Lindorf plate holding instrument 1.0 mm
	25-435-15-07	① oder Lindorf-Platten-Halteinstrument 1.5 mm	or Lindorf plate holding instrument 1.5 mm
	25-435-20-07	① oder Lindorf-Platten-Halteinstrument 2.0 mm	or Lindorf plate holding instrument 2.0 mm
	25-435-25-07	① oder Lindorf-Platten-Halteinstrument 2.0 mm Champy	or Lindorf plate holding instrument 2.0 mm Champy
	50-502-10-07	② Multifunktionszange für 1.0/1.5/2.0 mm	Multifunctional plate bender 1.0/1.5/2.0 mm
	50-502-11-07	① Schneidezange für 1.0/1.5/2.0 mm	Multifunctional plate cutter 1.0/1.5/2.0 mm
	55-969-57-04	Instrumententray Basic, konfiguriert 15 x 30 cm vorbereitet für:	Instrument tray, basic, preconfigured 15 x 30 cm prepared for:
	25-402-99-07	② Schraubendreherhandgriff, mittel	Screwdriver handle, medium
	25-406-99-07	② Schraubendreherhandgriff, groß	Screwdriver handle, large
	25-420-16-07	① Plattenschneidezange	Plate cutter
	25-496-15-09	① Plattenhaltepinzette	Plate holding forceps
	25-510-12-07	① Biegezange KLS-Martin-Mini-System	Bending pliers, KLS Martin mini system
	25-516-13-07	② Modellierzange	Modelling pliers



		<i>Recomendaciones de set</i>	<i>Sets recommandés</i>	<i>Suggerimenti per le composizioni</i>
55-969-26-04		Bandeja de instrumentos multi, preconfigurada, 15 x 30 cm, preparada para:	Plateau pour instruments Multi, configuré 15 x 30 cm, préparé pour:	Bacinella portastrumenti multi, preconfigurata, 15 x 30 cm, preparata per:
25-402-99-07	2	Mango de destornillador, mediano	Poignée pour tournevis, moyenne	Manico cacciavite, medio
25-406-99-07	2	Mango de destornillador, grande	Poignée pour tournevis, grande	Manico cacciavite, grande
25-435-10-07	1	Instrumento para sujetar placas Lindorf, 1.0 mm	Instrument à saisir les plaques Lindorf 1.0 mm	Strumento portaplacche Lindorf da 1.0 mm
25-435-15-07	1	o instrumento para sujetar placas Lindorf, 1.5 mm	ou instrument à saisir les plaques Lindorf 1.5 mm	o strumento portaplacche Lindorf da 1.5 mm
25-435-20-07	1	o instrumento para sujetar placas Lindorf, 2.0 mm	ou instrument à saisir les plaques Lindorf 2.0 mm	o strumento portaplacche Lindorf da 2.0 mm
25-435-25-07	1	o instrumento para sujetar placas Lindorf, 2.0 mm Champy	ou instrument à saisir les plaques Lindorf Champy 2.0 mm	o strumento portaplacche Lindorf da 2.0 mm Champy
50-502-10-07	2	Alicates multifuncionales para 1.0/1.5/2.0 mm	Pince multifonctions pour 1.0/1.5/2.0 mm	Pinza multifunzione per 1.0/1.5/2.0 mm
50-502-11-07	1	Alicates de corte para 1.0/1.5/2.0 mm	Pince à couper pour 1.0/1.5/2.0 mm	Pinza di taglio per 1.0/1.5/2.0 mm
55-969-57-04		Bandeja de instrumentos basic, preconfigurada, 15 x 30 cm, preparada para:	Plateau pour instruments Basic, configuré 15 x 30 cm, préparé pour:	Bacinella portastrumenti base, preconfigurata, 15 x 30 cm, preparata per:
25-402-99-07	2	Mango de destornillador, mediano	Poignée pour tournevis, moyenne	Manico cacciavite, medio
25-406-99-07	2	Mango de destornillador, grande	Poignée pour tournevis, grande	Manico cacciavite, grande
25-420-16-07	1	Alicates para cortar placas	Pince coupante pour plaques	Pinza per taglio delle placche
25-496-15-09	1	Pinza para sujetar placas	Pince à saisir les plaques	Pinze per tenuta placche
25-510-12-07	1	Alicates para doblar, sistema mini de KLS Martin	Pince à cintrer système Mini KLS Martin	Pinze piegaplacche sistema Mini KLS Martin
25-516-13-07	2	Alicates de modelado	Pince à modeler	Pinze per modellare

Nummern-Index

Index of order numbers

Índice de números de referencia

Index numérique des références de commande

Elenco dei codici

11

11-995-12-0727

25

25-003-02-0919

25-003-02-7119

25-003-10-0916

25-003-10-7116

25-004-02-0919

25-004-02-7119

25-004-25-0917

25-004-50-0918

25-004-50-7118

25-004-70-0918

25-004-70-7118

25-004-90-0918

25-004-90-7118

25-005-10-0916

25-005-10-7116

25-005-12-0916

25-005-12-7116

25-006-12-0916

25-006-12-7116

25-007-80-0914

25-007-80-7114

25-008-12-0915

25-008-20-0915

25-008-80-0914

25-008-80-7114

25-015-03-0919

25-015-03-7119

25-015-04-09...19, 30, 31

25-015-04-7119

25-015-06-09...19, 30, 31

25-015-06-7119

25-015-08-09...19, 30, 31

25-015-08-7119

25-015-24-0919

25-015-24-7119

25-016-06-09...19, 30, 31

25-016-06-7119

25-016-10-09...19, 30, 31

25-016-10-7119

25-017-04-0919

25-017-04-7119

25-017-06-0919

25-017-06-7119

25-017-08-0919

25-017-08-7119

25-017-16-0919

25-017-16-7119

25-017-24-0919

25-017-24-7119

25-018-06-0919

25-018-06-7119

25-018-08-0919

25-018-08-7119

25-018-16-0919

25-018-16-7119

25-042-15-0920

25-042-15-7120

25-042-16-0920

25-042-16-7120

25-043-01-0920

25-043-01-7120

25-043-02-0920

25-043-02-7120

25-050-00-0726

25-050-98-0726

25-052-18-0727

25-068-04-0912

25-068-06-0912

25-068-08-0912

25-068-10-0912

25-301-01-0913

25-301-02-0913

25-301-03-0913

25-301-04-0913

25-301-05-0913

25-301-06-0913

25-301-17-0913

25-301-19-0913

25-301-31-0913

25-301-32-0913

25-302-12-09...8, 30, 31

25-302-12-718

25-302-12-918

25-302-70-09...8, 30, 31

25-302-70-718

25-302-70-918

25-304-00-09...8, 28, 29,
.....30, 31

25-304-00-718

25-304-00-918

25-304-55-09...8, 28, 29

25-304-55-718

25-304-55-918

25-304-70-098

25-304-70-718

25-304-70-918

25-304-85-09...8, 30, 31

25-304-85-718

25-304-85-918

25-306-00-09...8, 28, 29

25-306-00-718

25-306-00-918

25-306-55-09...8, 28, 29

25-306-55-718

25-306-55-918

25-306-70-098

25-306-70-718

25-306-70-918

25-306-85-098

25-306-85-718

25-306-85-918

25-308-00-09...8, 28, 29

25-308-00-718

25-308-00-918

25-310-55-099

25-310-55-719

25-310-55-919

25-310-70-09...9, 28, 29

25-310-70-719

25-310-70-919

25-310-85-09...9, 28, 29

25-310-85-719

25-310-85-919

25-311-55-099

25-311-55-719

25-311-55-919

25-311-70-09...9, 28, 29

25-311-70-719

25-311-70-919

25-311-85-09...9, 28, 29

25-311-85-719

25-311-85-919

25-312-55-099

25-312-55-719

25-312-55-919

25-312-70-099

25-312-70-719

25-312-70-919

25-312-85-099

25-312-85-719

25-312-85-919

25-313-55-099

25-313-55-719

25-313-55-919

25-313-70-099

25-313-70-719

25-313-70-919

25-313-85-099

25-313-85-719

25-313-85-919

25-314-85-09...9, 28, 29

25-314-85-719

25-314-85-919

25-315-06-09...10, 28, 29

25-315-06-7110

25-315-06-9110

25-315-85-09...9, 28, 29

25-315-85-719

25-315-85-919

25-316-00-09...8, 28, 29,
.....30, 31

25-316-00-718

25-316-00-918

25-316-06-9110

25-317-06-9110

25-320-00-098

25-320-00-718

25-320-00-918

25-320-55-0910

25-320-55-7110

25-320-55-9110

25-320-70-09...10, 28,
.....29, 30, 31

25-320-70-7110

25-320-70-9110

25-320-85-0910

25-320-85-7110

25-320-85-9110

25-322-55-09...10, 28, 29

25-322-55-7110

25-322-55-9110

25-322-70-09...10, 30, 31

25-322-70-7110

25-322-70-9110

25-322-85-0910

25-322-85-7110

25-322-85-9110

25-325-06-098

25-325-06-718

25-325-06-918

25-325-08-098

25-325-08-718

25-325-08-918

25-325-10-09...8, 28, 29

25-325-10-718

25-325-10-918

25-326-55-09...10, 28, 29

25-326-55-7110

25-326-55-9110

25-328-12-0910

25-328-12-7110

25-328-12-9110

25-329-01-0910

25-329-01-7110

25-329-02-0910

25-329-02-7110

25-329-05-09...10, 28, 29

25-329-05-7110

25-330-05-09...11, 28, 29

25-330-05-7111

25-330-07-09...10, 28, 29

25-330-07-7110

25-330-10-0911

25-330-10-7111

25-330-10-9111

25-330-24-09...8, 28, 29

25-330-24-718

25-330-70-0911

25-330-70-7111

25-330-70-9111

25-330-85-09...11, 28, 29

25-330-85-7111

25-330-85-9111

25-331-05-09...11, 28, 29

25-331-05-7111

25-331-10-0911

25-331-10-7111

25-331-10-9111

25-331-70-0911

25-331-70-7111

25-331-70-9111

25-331-85-09...11, 28, 29

25-331-85-7111

25-331-85-9111

25-336-11-0911

25-336-11-7111

25-336-11-9111

25-337-11-0911

25-337-11-7111

25-337-11-9111

25-346-16-0912

25-402-99-07...6, 36, 37

25-406-99-07...36, 37

25-407-03-046

25-407-04-046

25-407-05-046

25-412-12-0724

25-416-13-0724

25-420-16-07...24, 36, 37

25-422-15-076

25-423-15-076

25-516-13-07.....	36, 37
25-650-02-04.....	5
25-651-01-04.....	5
25-665-03-09.....	4
25-665-03-75.....	4
25-665-04-09.....	4
25-665-04-75.....	4
25-665-05-09.....	4
25-665-05-75.....	4
25-665-06-09.....	4
25-665-06-75.....	4
25-665-07-09.....	4
25-665-07-75.....	4
25-665-08-09.....	4
25-665-08-75.....	4
25-665-09-09.....	4
25-665-09-75.....	4
25-665-11-09.....	4
25-665-11-75.....	4
25-665-13-09.....	4
25-665-13-75.....	4
25-665-15-09.....	4
25-665-15-75.....	4
25-666-03-09.....	4
25-666-03-75.....	4
25-666-05-09.....	4
25-666-05-75.....	4
25-666-07-09.....	4
25-666-07-75.....	4
25-668-04-09.....	4
25-668-04-75.....	4
25-668-05-09.....	4
25-668-05-75.....	4
25-668-06-09.....	4
25-668-06-75.....	4
25-668-07-09.....	4
25-668-07-75.....	4
25-675-03-09.....	5
25-675-03-75.....	5
25-675-04-09.....	5
25-675-04-75.....	5
25-675-05-09.....	5
25-675-05-75.....	5
25-675-06-09.....	5
25-675-06-75.....	5
25-675-07-09.....	5
25-675-07-75.....	5
25-675-08-09.....	5
25-675-08-75.....	5
25-675-09-09.....	5
25-675-09-75.....	5
25-675-11-09.....	5
25-675-11-75.....	5
25-675-13-09.....	5
25-675-13-75.....	5
25-675-15-09.....	5
25-675-15-75.....	5
25-676-03-09.....	5
25-676-03-75.....	5
25-676-05-09.....	5

25-676-05-75.....	5
25-676-07-09.....	5
25-676-07-75.....	5
25-678-04-09.....	5
25-678-04-75.....	5
25-678-05-09.....	5
25-678-05-75.....	5
25-678-06-09.....	5
25-678-06-75.....	5
25-678-07-09.....	5
25-678-07-75.....	5
25-875-03-09.....	4
25-875-03-75.....	4
25-875-04-09.....	4
25-875-04-75.....	4
25-875-05-09.....	4
25-875-05-75.....	4
25-875-06-09.....	4
25-875-06-75.....	4
25-875-07-09.....	4
25-875-07-75.....	4
25-875-08-09.....	4
25-875-08-75.....	4
25-875-09-09.....	4
25-875-09-75.....	4
25-875-11-09.....	4
25-875-11-75.....	4
25-875-13-09.....	4
25-875-13-75.....	4
25-875-15-09.....	4
25-875-15-75.....	4
25-875-17-09.....	4
25-875-19-09.....	4
25-876-03-09.....	4
25-876-03-75.....	4
25-876-04-09.....	4
25-876-05-09.....	4
25-876-05-75.....	4
25-876-07-09.....	4
25-876-07-75.....	4
25-878-03-09.....	4
25-878-04-09.....	4
25-878-04-75.....	4
25-878-05-09.....	4
25-878-05-75.....	4
25-878-06-09.....	4
25-878-07-09.....	4
25-878-07-75.....	4
50	
50-280-00-09.....	22, 32, 33
50-280-03-09.....	22, 32, 33
50-280-05-09.....	22, 32, 33
50-280-07-09.....	22, 32, 33
50-280-09-09.....	22, 32, 33
50-280-11-09.....	22, 32, 33
50-282-00-09.....	22, 32, 33
50-282-03-09.....	22, 32, 33
50-282-05-09.....	22, 32, 33
50-282-07-09.....	22, 32, 33
50-282-09-09.....	22, 32, 33
50-282-11-09.....	22, 32, 33
50-302-01-09.....	23, 32, 33
50-302-03-09.....	23, 32, 33
50-302-05-09.....	23, 32, 33
50-302-07-09.....	23, 32, 33
50-302-09-09.....	23, 32, 33
50-302-11-09.....	23, 32, 33
50-310-08-09.....	21
50-310-08-71.....	21
50-310-09-09.....	21
50-310-09-71.....	21
50-310-11-09.....	21
50-310-11-71.....	21
50-310-12-09.....	21
50-310-12-71.....	21
50-310-17-09.....	21
50-310-17-71.....	21
50-310-22-09.....	21, 30, 31
50-310-22-71.....	21
50-310-27-09.....	21, 30, 31
50-310-27-71.....	21
50-310-32-09.....	21
50-310-32-71.....	21
50-340-08-09.....	12
50-340-10-09.....	12
50-340-12-09.....	12
50-340-13-09.....	12
50-345-13-09.....	12
50-502-10-07.....	25, 36, 37
50-502-11-07.....	25, 36, 37
50-502-98-07.....	25
50-502-99-07.....	25
50-511-05-07.....	7
50-511-05-71.....	7
50-511-35-07.....	7
50-511-35-71.....	7
50-920-00-07.....	7
50-920-07-07.....	7

55

55-961-02-04.....	28, 29
55-961-03-04.....	32, 33
55-961-04-04.....	30, 31
55-961-28-04.....	13
55-962-02-0.....	28, 29, 30, 31, 32, 33
55-962-07-04.....	13
55-962-12-04.....	20, 28, 30, 32
55-962-22-04.....	29, 31, 33
55-962-32-04.....	29, 31, 33
55-963-02-04.....	28, 29
55-963-03-04.....	32, 33
55-963-04-04.....	30, 31
55-963-05-04.....	20
55-963-08-04.....	29, 31, 33
55-963-09-04.....	28, 30, 32
55-963-15-04.....	34, 35
55-963-16-04.....	34, 35
55-963-30-04.....	34, 35
55-963-44-04.....	13
55-964-02-04.....	28, 29
55-964-04-04.....	30, 31
55-964-06-04.....	28, 29
55-964-11-04.....	32, 33
55-964-12-04.....	32, 33
55-964-15-04.....	34, 35
55-964-17-04.....	30, 31
55-964-30-04.....	34, 35
55-964-53-04.....	13
55-964-54-04.....	13
55-969-14-04.....	34, 35
55-969-15-04.....	34, 35
55-969-16-04.....	34, 35
55-969-26-04.....	34, 35, 36, 37
55-969-47-04.....	34, 35
55-969-57-04.....	34, 35, 36, 37
55-969-70-04.....	12
55-969-93-04.....	34, 35
55-969-94-04.....	34, 35
55-969-96-04.....	34, 35
55-969-97-04.....	34, 35
55-969-98-04.....	34, 35
55-969-99-04.....	34, 35

99

99-340-08-04.....	12
99-340-10-04.....	12
99-340-12-04.....	12
99-340-13-04.....	12

KLS Martin Group

KLS Martin France SARL
68200 Mulhouse · France
Tel. +33 3 89 51 31 50
france@klsmartin.com

KLS Martin UK Ltd.
Reading RG1 3EU · United Kingdom
Tel. +44 1189 000 570
uk@klsmartin.com

KLS Martin do Brasil Ltda.
CEP 04.531-011 São Paulo · Brazil
Tel.: +55 11 3554 2299
brazil@klsmartin.com

Gebrüder Martin GmbH & Co. KG
Representative Office
121471 Moscow · Russia
Tel. +7 499 792-76-19
russia@klsmartin.com

Martin Italia S.r.l.
20864 Agrate Brianza (MB) · Italy
Tel. +39 039 605 6731
italia@klsmartin.com

Nippon Martin K.K.
Osaka 541-0046 · Japan
Tel. +81 6 6228 9075
nippon@klsmartin.com

KLS Martin Australia Pty Limited
Artarmon NSW 2064 · Australia
Tel.: +61 2 9439 5316
australia@klsmartin.com

Gebrüder Martin GmbH & Co. KG
Representative Office
201203 Shanghai · China
Tel. +86 21 5820 6251
china@klsmartin.com

Martin Nederland/Marned B.V.
1271 AG Huizen · The Netherlands
Tel. +31 35 523 4538
nederland@klsmartin.com

KLS Martin L.P.
Jacksonville, FL 32246 · USA
Tel. +1 904 641 7746
usa@klsmartin.com

KLS Martin SE Asia Sdn. Bhd.
14100 Simpang Ampat, Penang · Malaysia
Tel.: +604 505 7838
malaysia@klsmartin.com

Gebrüder Martin GmbH & Co. KG
Representative Office
Dubai · United Arab Emirates
Tel. +971 4 454 1655
middleeast@klsmartin.com

Gebrüder Martin GmbH & Co. KG
A company of the KLS Martin Group
KLS Martin Platz 1 · 78532 Tuttlingen · Germany
Postfach 60 · 78501 Tuttlingen · Germany
Tel. +49 7461 706-0 · Fax +49 7461 706-193
info@klsmartin.com · www.klsmartin.com

