



---

## **L1**<sup>®</sup> Mandible ReconGuide

Resection guides for mandibular  
reconstruction with fibula graft



Oral and maxillo-facial surgery is our passion! Its further development, together with our customers, is our ambition. Every day we work on developing innovative products and services which meet the highest demands on quality, and which contribute to the wellbeing of the patient.

## Table of Contents

|  | Pages |
|--|-------|
| Introduction   | 4-5   |
| Product Features   | 6-11  |
| Indications and Surgical Technique   | 12-35 |
| ■ Assembly of Resection Guides   | 14-17 |
| ■ Mandibular Reconstruction with Microvascular<br>Fibula Graft                           | 18-35 |
| - Resection of the Mandible with the<br>Mandibular Resection Guide                       | 18-22 |
| - Resection of the Fibula and Primary Graft Fixation<br>with the Fibular Resection Guide | 34-35 |
| - Placement of the Graft in the Mandible   | 34-35 |
| Product Range  |       |
| ■ Instruments  | 36-41 |
| ■ Implants   | 42-45 |
| ■ Storage  | 42-45 |



---

## L1® Mandible ReconGuide

### Resection guides for mandibular reconstruction with fibula graft

Mandibular defects due to trauma, infections, or tumors considerably impair the patient's quality of life, not only physiologically but also psychologically.

Despite the progress made in microvascular reconstruction techniques it remains a demanding challenge to return the mandible to its original anatomical shape and restore functional and aesthetic aspects.

Product improvements in recent years have mainly addressed computerized approaches in combination with patient-specific resection guides and implants, with the aid of which preoperative planning can be transferred to real-time surgery.

In the field of standardized products there has been very little progress, although there is a need for improvement and innovation here too.

The L1® Mandible ReconGuide now available provides an innovative, reusable standard solution that assists the surgeon with conventional resection in everyday clinical routine.

## Features, Functions, and Benefits

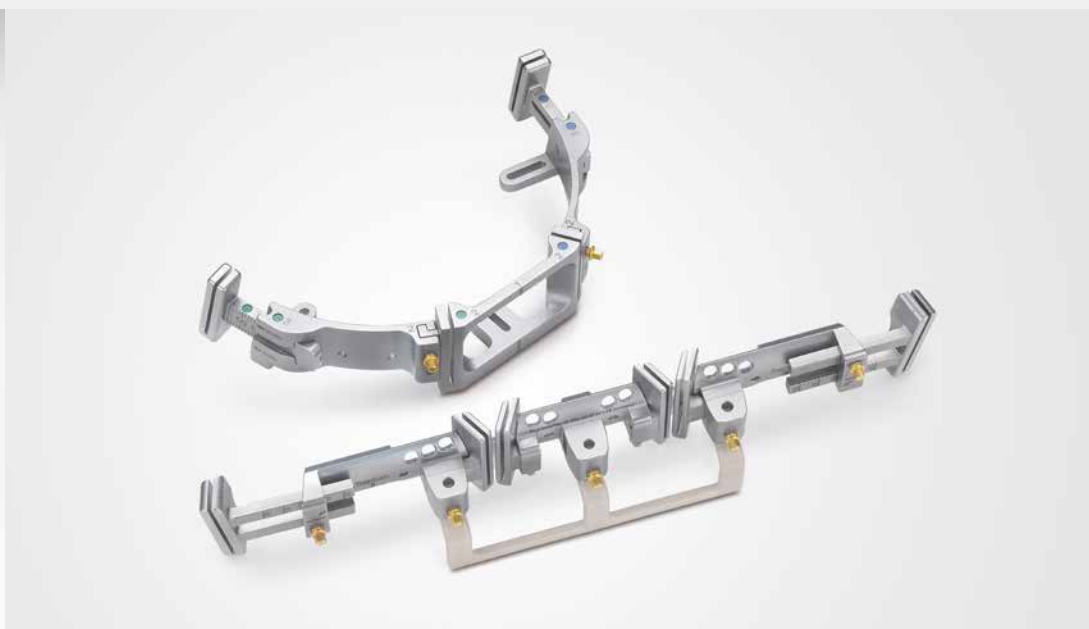

In addition to computerized approaches in combination with patient-specific products, KLS Martin has set itself the goal of also developing innovative solution approaches for conventional reconstruction.

The L1® Mandible ReconGuide now available provides two universal, reusable resection guides, with the aid of which osteotomies can be performed on the mandible and fibula for the purpose of mandibular reconstruction using a microvascular fibula graft based on a defined, coordinated resection pattern.

Easy adjustment of the required resection length makes it possible to adapt to individual anatomical situations.

After resection the fibula bone segments are placed in the required angular position using a special fixation bar – the arduous manual arrangement and holding together of the segments during osteosynthesis is thus completely eliminated.

In this position the new miniplates, which have been pre-bent according to the angulation of the graft, can be introduced from above through recesses integrated in the guide, and then easily fixated.

A unique feature that facilitates graft fixation enormously!

# L1® Mandible ReconGuide – Instruments

## Features

## Benefits

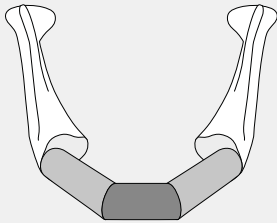

- Defined one-, two- or three-segment resection of the mandible and coordinated resection of the fibula:
  - Right mandibular body
  - Symphysis
  - Left mandibular body

- Defined incision and precise cut surfaces
- Graft coordinated with and matching the defect, without any manual modeling of bone segments
- Standardization of conventional resection

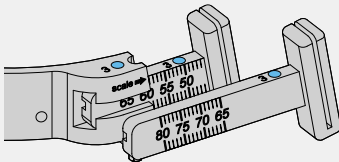

- Length adjustments in the posterior region of the mandibular body:
  - Short saw guide 45-65 mm
  - Long saw guide 65-80 mm

- Enables adjustment of the required resection area
- Customization to suit anatomical situations

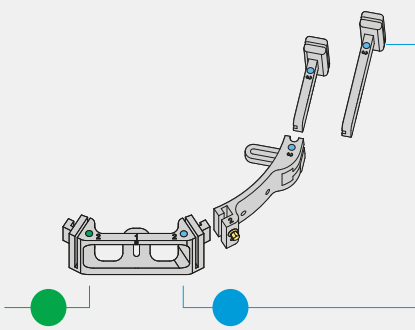

- Colored and numerical marking:
  - Colored dots for side-specific assignment of guide segments
  - Numbers for arrangement in the correct sequence

- Clear marking and intuitive assignment of guide segments
- Facilitates assembly considerably

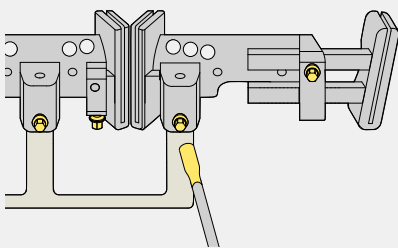

- Gold-colored, fixated hexagon screws for attachment of the individual guide segments to each other and coordinated color-coded screwdriver blade

- Easy recognition and intuitive assignment of components that belong together
- Easy fixation and detachment of the guide segments
- No loss of small parts

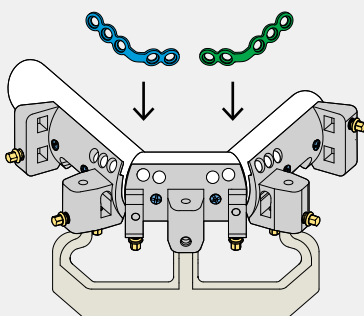

- Arrangement of the resected fibula segments in an angular position using the angled fixation bar
- Integrated recesses for osteosynthesis and specially coordinated miniplates

- No manual arrangement or holding together of bone segments during osteosynthesis
- Enables graft fixation while the guide is still in place
- Facilitation and time benefit in primary fixation of the graft

## Features, Functions, and Benefits



In developing the L1® Mandible ReconGuide resection guides the focus was on holistic simplification of the challenging surgery, in order to offer the user the best possible assistance and ensure optimal results for all those involved in the process.



In light of this background, the miniplates, which have a profile thickness of 1.0 mm and are specially coordinated with the surgical procedure, serve to round off the system and substantially facilitate the time-consuming step of osteosynthesis.

The additional feature of recesses integrated into the fibular resection guide enables primary fixation of the graft while the guide is still in place because the two dedicated miniplates, which are contoured according to the angulation of the graft, are introduced and fixated from above.

For easy identification and differentiation the two special plates are color-coded according to the color marking of the guide and can thus be assigned to a specific side. All the other, universal plates are grey.

In combination with the maxDrive® screw, which has a diameter of 2.0 mm, conditions are ideal for ensuring successful osteosynthesis.

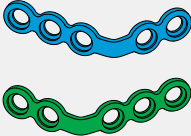
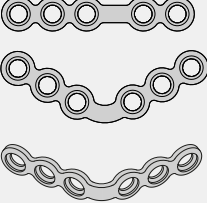
# L1® Mandible ReconGuide – Implants

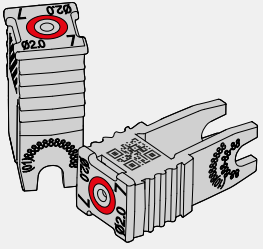
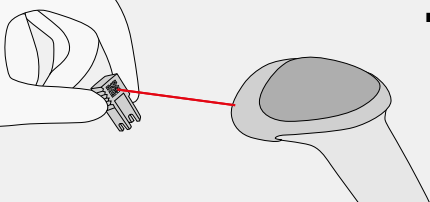
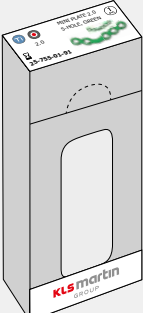
|   | Features   | Benefits   |
|---|--|--|
|    | <ul style="list-style-type: none"> <li>Special plates coded according to the color of the guide               <ul style="list-style-type: none"> <li>- <b>Blue:</b> for right guide recess</li> <li>- <b>Green:</b> for left guide recess</li> </ul> </li> </ul> | <ul style="list-style-type: none"> <li>Easy recognition and side-specific assignment</li> </ul>  |
|    | <ul style="list-style-type: none"> <li>Preshaped miniplates coordinated with the graft, profile thickness 1.0 mm</li> </ul>  | <ul style="list-style-type: none"> <li>Good plate fit with minimal intraoperative adjustment</li> <li>Facilitates graft fixation</li> <li>High strength due to reduced amount of bending</li> </ul>      |
|  | <ul style="list-style-type: none"> <li>Detachable ID tag with article number, batch number, GTIN number, and Data Matrix code</li> </ul>   | <ul style="list-style-type: none"> <li>Enables reading of all the relevant data, even in the case of very small implants</li> <li>Simplified reordering</li> </ul>                                       |
|  | <ul style="list-style-type: none"> <li>Screws in color-coded single clip with article number, batch number, GTIN number, and Data Matrix code</li> </ul>   | <ul style="list-style-type: none"> <li>Clear assignment of the respective screw diameter</li> <li>Direct, swift and application-oriented access to the screw</li> <li>Chargeable individually</li> </ul> |
|  | <ul style="list-style-type: none"> <li>Data Matrix code for scanning</li> </ul>  | <ul style="list-style-type: none"> <li>Easy recording of all implant data by scanning the Data Matrix code</li> <li>100% batch traceability and transparent, patient-related documentation</li> </ul>    |
|  | <ul style="list-style-type: none"> <li>All implants available in sterile and non-sterile packaging</li> </ul>  | <ul style="list-style-type: none"> <li>Maximum selection for the customer</li> </ul>   |

## Features, Functions, and Benefits



The storage concept was matched to the special requirements of mandibular reconstruction and considers the strict separation of the surgical zones "Mandible" and "Fibula".

In addition to easy handling, for example with the instruments arranged according to procedure and the sequence of assembly, the storage system is also impressive because of optimized reprocessing capability due to large openings, in order to equally serve the needs of all those involved in the process.

# L1® Mandible ReconGuide – Storage

## Features

## Benefits

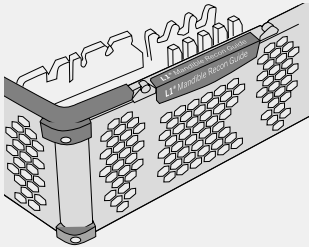

- Stainless steel storage trays in honeycomb design combined with high-performance plastic

- High strength, light weight
- Good rinsing results due to large openings

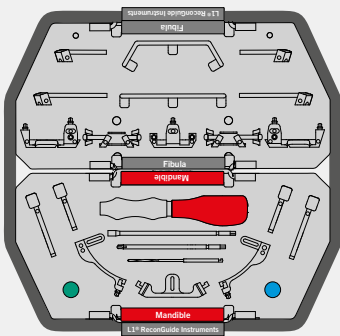

- Clear marking and strict separation of instruments and implants for the surgical zones "Mandible" and "Fibula".
  - Red labeling clips: Septic surgical zone "Mandible"
  - Gray labeling clips: Surgical zone "Fibula"

- Clear marking and recognizability
- Facilitates assignment of the systems to the two surgical zones

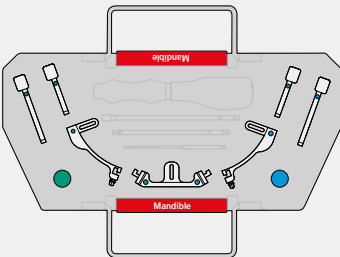

- In the storage tray the guide segments are arranged according to the sequence of assembly

- Swift and intuitive assembly of the guides
- Transparent organization and arrangement

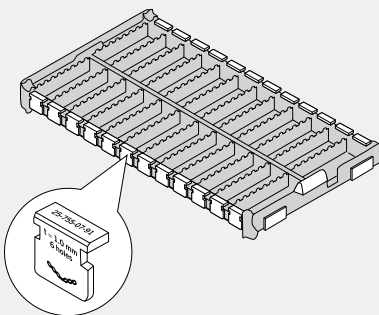

- Each compartment in the plate module is marked with a labeling clip that bears the article number, the plate profile, and a picture of the plate.

- Application-oriented access to the plate and intuitive refilling

- Matt, dark inner surface

- Transparent arrangement

- Increased contrast and good recognition of plates, even in surgical light

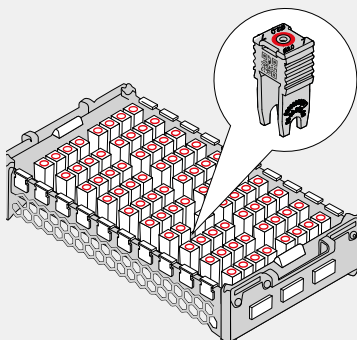

- Single screw clips can be taken out of the screw module from any position.

- Easy refilling

## Step by Step to Optimal Treatment



## Indications

Resection and reconstruction of the mandible using a microvascular fibula graft

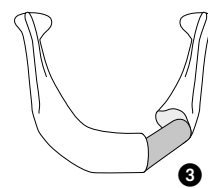
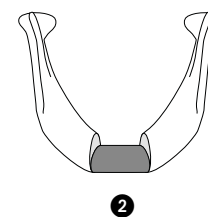
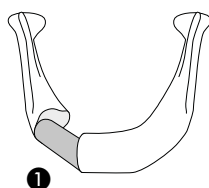
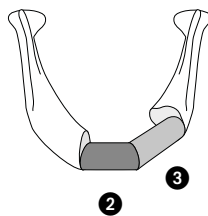
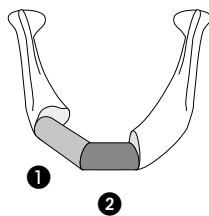
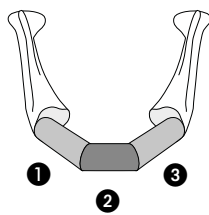

One-, two- or three-segment resection  
according to anatomical regions:

- ① Right mandibular body
- ② Symphysis
- ③ Left mandibular body



## Surgical Technique

### 1. Assembly of the Resection Guides

Pages 14-17



### 2. Mandibular Reconstruction with Microvascular Fibula Graft

Pages 18-35

1. Resection of the Mandible with the Mandibular Resection Guide
2. Resection of the Fibula and Primary Graft Fixation with the Fibular Resection Guide
3. Placement of the Graft in the Mandible

Prof. Dr. Dr. Kesting, Dr. Dr. Weitz

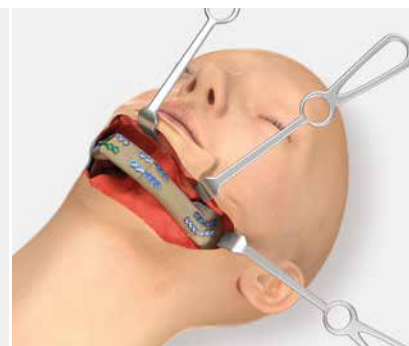

## Assembly of the Mandibular Resection Guide

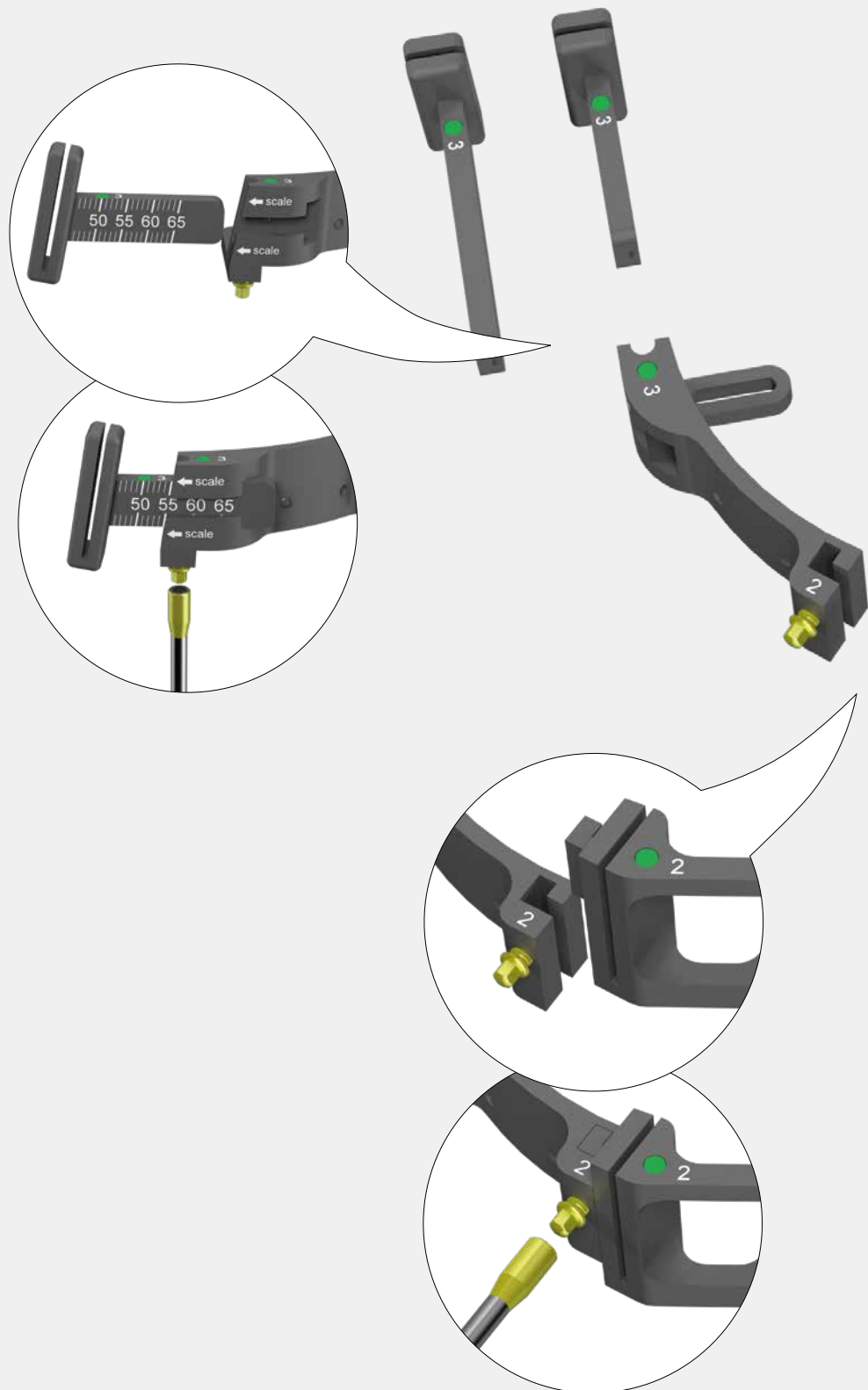

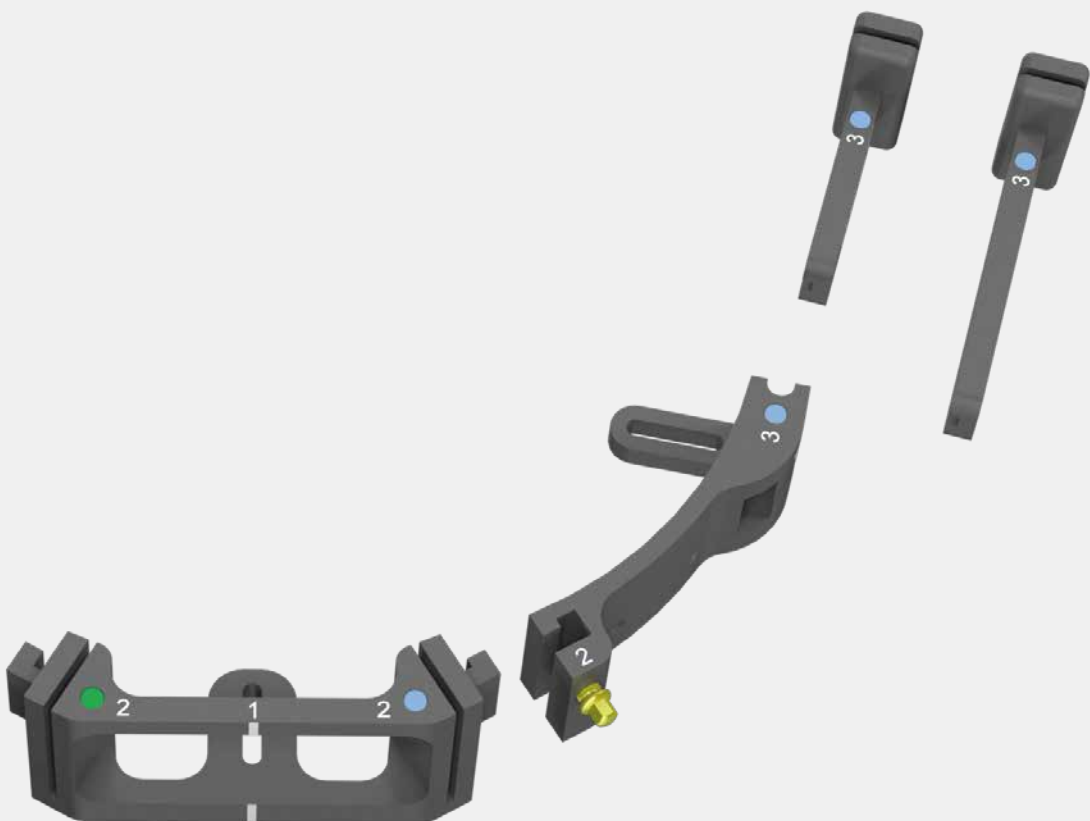

Side-specific assignment of the segments:

- **Green colored dot:** segments of the right side of the guide
- **Blue colored dot:** segments of the left side of the guide

The additional numerical marking allows the arrangement of the segments in the correct sequence, starting from the center of the symphysis segment (1).

- Segments with the same color and the same number belong together and have to be connected.



## Assembly of the Fibular Resection Guide

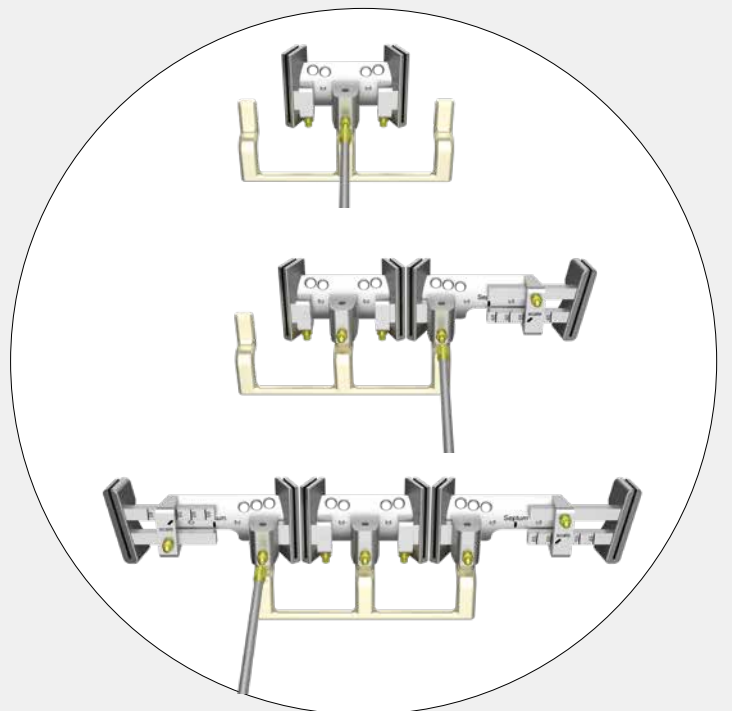
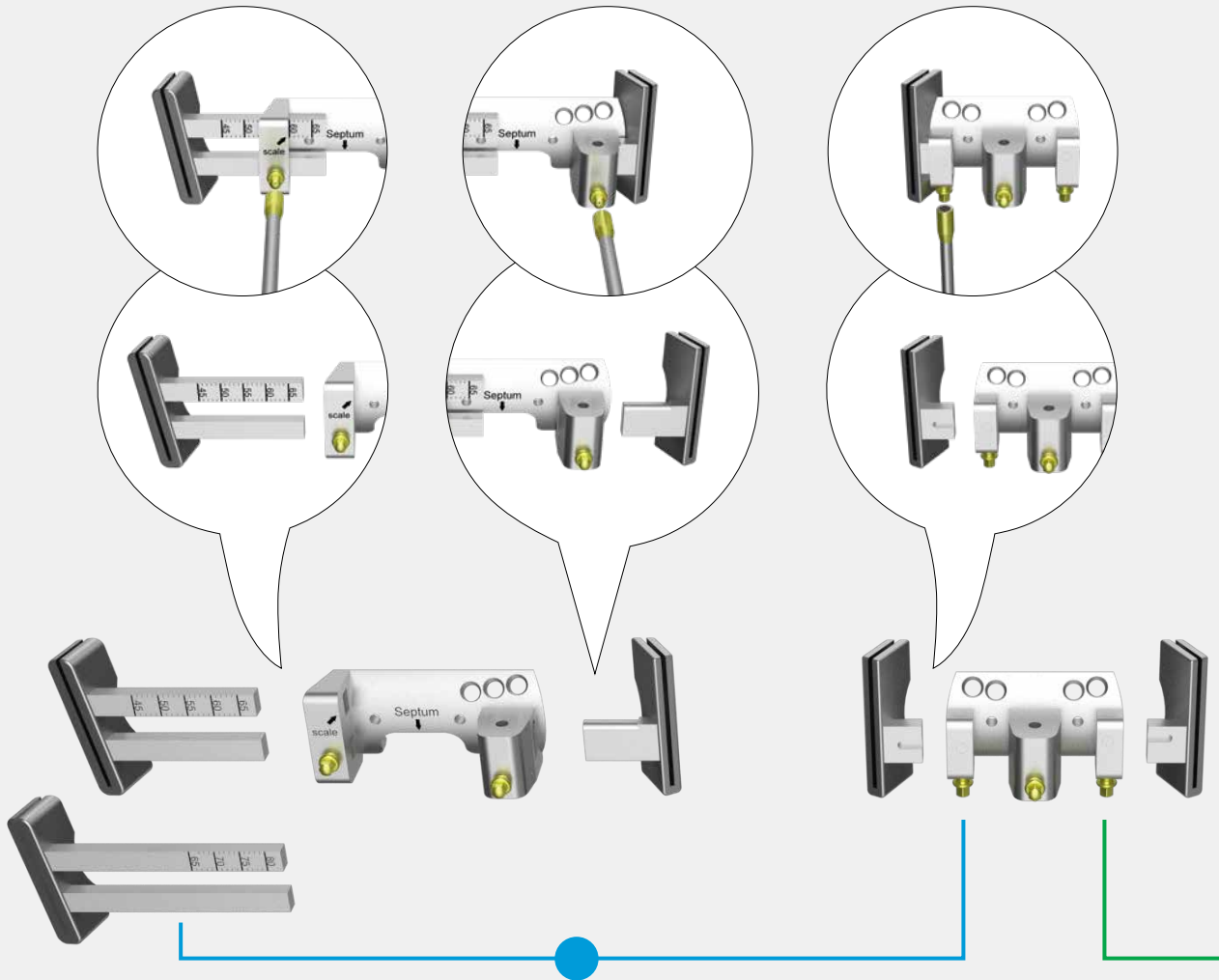

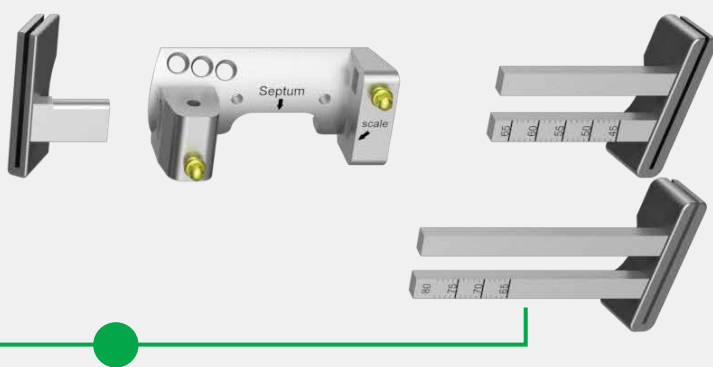

Side-specific assignment of the segments:

- **Green colored dot:** segments of the right side of the guide
- **Blue colored dot:** segments of the left side of the guide

The additional numerical marking allows the arrangement of the segments in the correct sequence, starting from the center of the symphysis segment (1).

- Segments with the same color and the same number belong together and have to be connected.



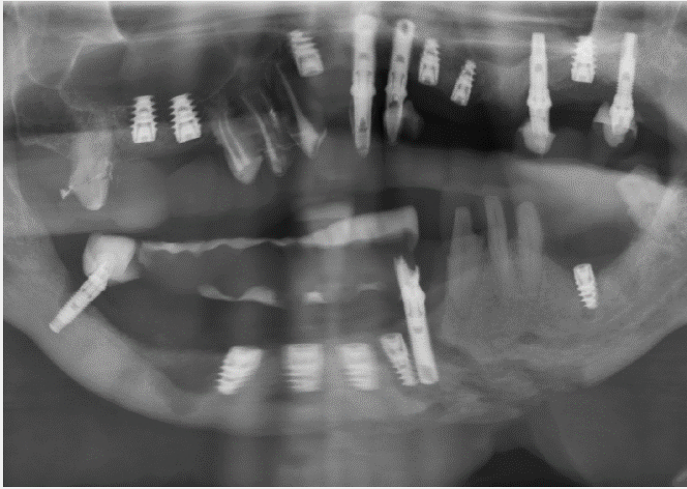

### Preoperative Planning

The x-ray image shows a pathological paramedian fracture on the left side with extensive osteomyelitis of the mandible. Due to the extensiveness and peri-implant inflammations in the mandible, mandibular continuity resection is planned.

The defect has to be reconstructed from the right using a microvascular 3-segment osteomyocutaneous fibula graft.

CT angiography of the lower legs shows correct bilateral 3-vessel supply.

The vascular anastomosis is to be performed on the left neck so the skin island comes to rest inside.

### Patient positioning

The patient is placed in the supine position on the operating table with the head hyperextended.

The leg to be operated on is positioned with the flexed knee away from the surgeon. The foot is fixated.

The two anatomical landmarks, head of fibula (Caput fibulae) and lateral malleolus (Malleolus lateralis), are marked.

#### *Note:*

*The instrument insert intended for the septic area of the mandible is marked with a red labeling clip "Mandible" so it is easy to distinguish from other components destined for the aseptic area "Fibula".*



### 1. Approach and exposure of the mandible

The corresponding approach and neck dissection are followed by preparation of the mandible, taking care to preserve the marginal mandibular branch of the facial nerve.

After incision of the periosteum and exposure of the bone the guide can be fixated and osteotomy of the mandible can be performed.



### 2. Application and alignment of the guide

After exposure, the resection guide is applied to the bony mandible. The three elongated holes on the underside of the guide serve as a supporting surface.

For correct alignment of the guide the centerline mark in the symphysis segment can be used for guidance.

*Note:*

*The resection size in the posterior region of the mandibular body should be estimated approximately so that lateral saw guides can now be selected accordingly and assembled:*

- Short saw guide: resection range 45-65 mm
- Long saw guide: resection range 65-80 mm

*In many cases, sawing a small notch in the bone leads to an improvement in the fit of the guide on the bone.*

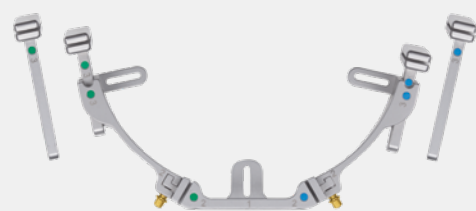

Mandibular resection guide

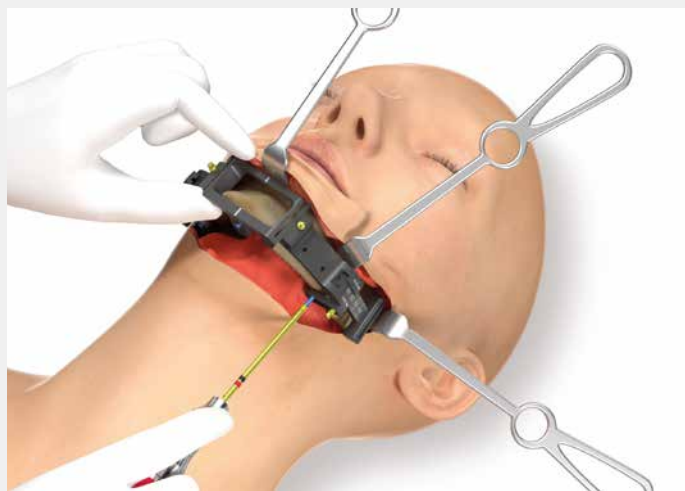
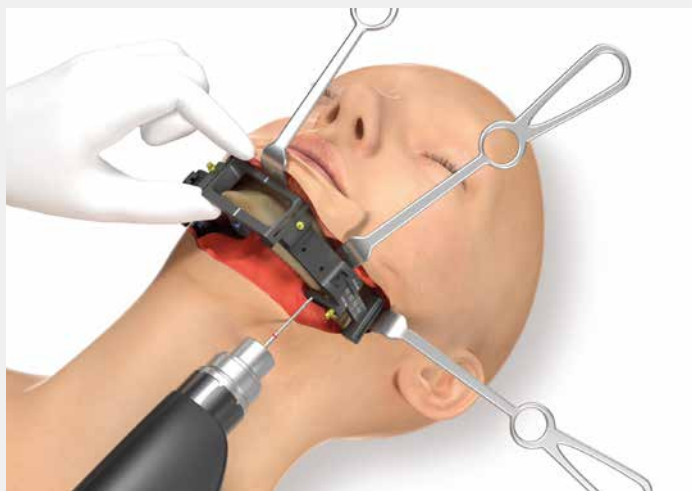

### 3. Temporary fixation of the guide to the mandible

The guide is temporarily fixated to the mandible with 2.0 mm dia. standard screws. In addition to the three elongated holes that enable fixation from below there are another four holes available for fixating the guide to the anterior region. By means of a combination the guide is attached ensuring rotational stability and tilt stability.

For fixation the respective core hole is first drilled with the corresponding drill bit. The 2.0 mm dia. standard screw is picked up and driven in with the red screwdriver for the septic area.

More screws are placed according to the described technique. Maximum hole filling is recommended.

*Note:*

*Screw length varies according to the size of the mandible.*

*Lengthy screws (approx. 11-15 mm) tend to be necessary in order to achieve adequate anchorage in the bone.*



Drill bit for 2.0 mm dia. screws

Screwdriver handle, red

maxDrive®-blade, dia. 2.0 mm



#### 4. Setting the resection value

The two outer saw guides can be set within the defined length range (45-65 mm or 65-80 mm, depending on the selection of the short or long guide) in increments of one millimeter.

For this purpose the gold-colored hexagon screw is loosened with the appropriate screwdriver blade so the saw guide can move freely to and fro and can be set to the required size.

The slanting, posterior edge of the lateral segment exhibits the read-off range, which is marked with the word "Scale" and an arrow.

For fixation of the final position the gold-colored hexagon screw is retightened.

*Note:*

*The set value is passed on to the team, who remove the fibula graft from the lower leg.*



Screwdriver handle, red



Hexagon blade, for tightening guide fixation screws



### 5. Performing the resection

The resection guide enables defined incision within the saw guides.

For defined osteotomy the saw blade must have the following characteristics and dimensions:

Sagittal saw blade

Cutting thickness: 0.6 mm

Width of working blade: 15 mm

Length: 27-40 mm

*Note:*

*To be able to achieve the best possible results it is always necessary to use not only a powerful motor system but also a new saw blade.*

### 6. Removal of the mandibular resection guide

After completion of resection the mandibular segment is removed and the resection guide can be removed by loosening the 2.0 mm dia. screws.



Screwdriver  
handle, red



maxDrive®  
blade,  
dia. 2.0 mm



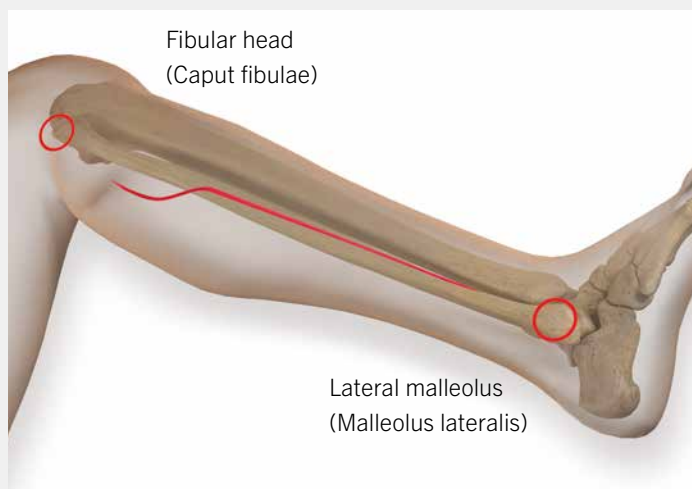

### 1. Approach

The incision line is drawn with a slight curvature; starting at about 6 cm distal to the fibular head in order to preserve the peroneus nerve.

The crural fascia is transected and the posterior septum is exposed. When the perforators in it have been localized they are marked.

Proximal to that the septum can be transected and the vascular pedicle can be sought in the flexor compartment and withdrawn.

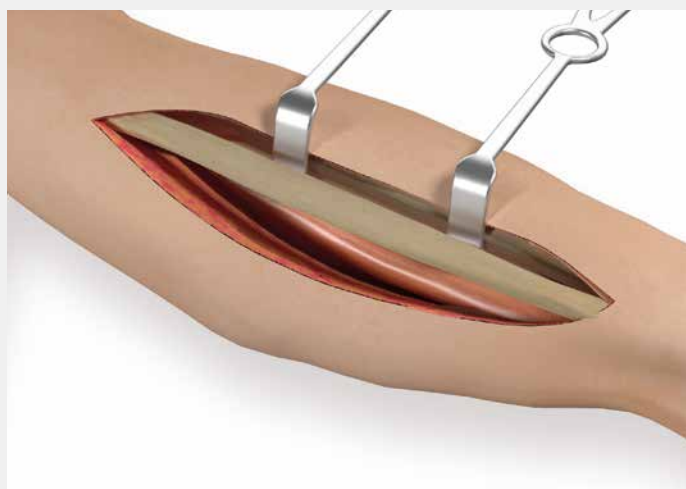

### 2. Exposure of the fibula

The peroneus muscle is displaced toward anterior and the anterior septum is transected. Then the guide can be placed on the fibula and the osteotomies can be performed (see step 5 ff.).

Alternatively, this step can also be performed after complete removal of the graft, with slightly more bone than necessary. Detachment of extensors from the fibula and sharp transection of the interosseous membrane. That is now followed by transection of the posterior tibial muscle approx. 1 cm away from the bone in order to preserve the vascular pedicle. Then, transection of the flexor hallucis longus muscle and circumcission of the skin island taking care to protect the perforators.

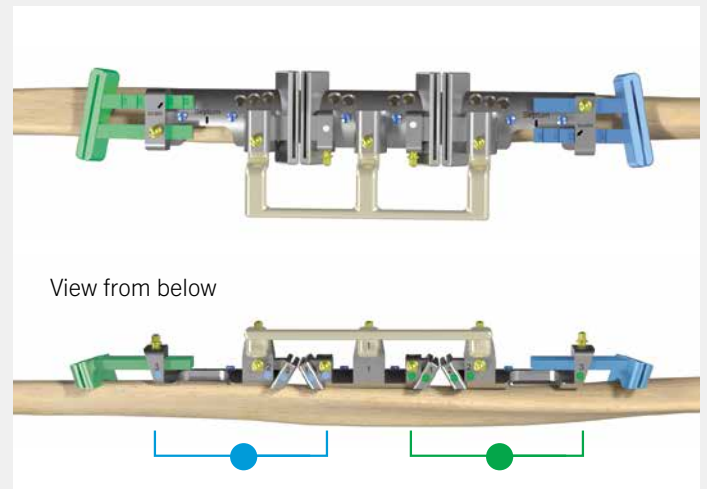
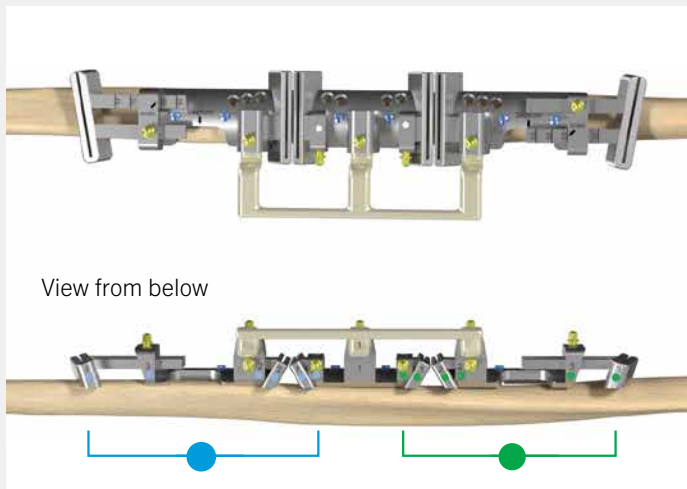

### 3. Preparation of the guide – checking of saw guides

#### Standard cases

The fibular resection guide can be used for the right and left fibula.

The guide is designed for the following standard cases:

#### Case deviations

If any of the following cases are to be realized, the two outer saw guides must be laterally swapped over so that the saw guide with the green dot is introduced on the blue or left side of the guide and the saw guide with the blue dot is introduced on the green or right side of the guide.

This ensures that the graft fits into the resected mandible.

| Removal site | Anastomosis        | Positioning of skin island |                     |
|--------------|--------------------|----------------------------|---------------------|
| Right fibula | Left side of neck  | Intraoral                  | <b>Standard use</b> |
| Left fibula  | Right side of neck | Intraoral                  | <b>Standard use</b> |

| Removal site | Anastomosis        | Positioning of skin island  |                                   |
|--------------|--------------------|-----------------------------|-----------------------------------|
| Right fibula | Right side of neck | Extraoral or no skin island | <b>Swap over outer saw guides</b> |
| Left fibula  | Left side of neck  | Extraoral or no skin island | <b>Swap over outer saw guides</b> |

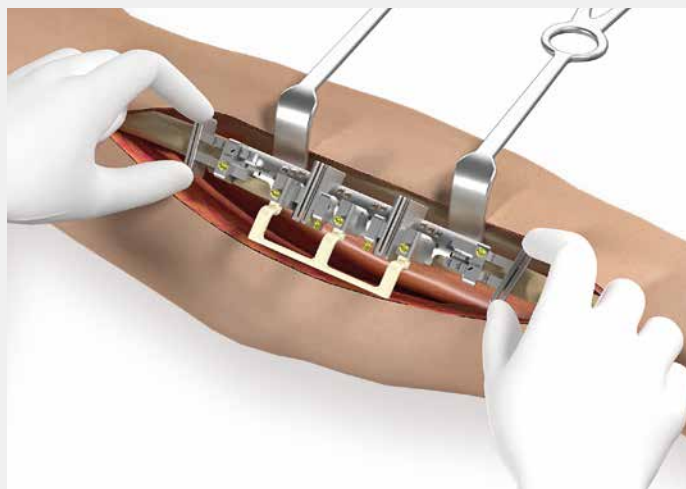
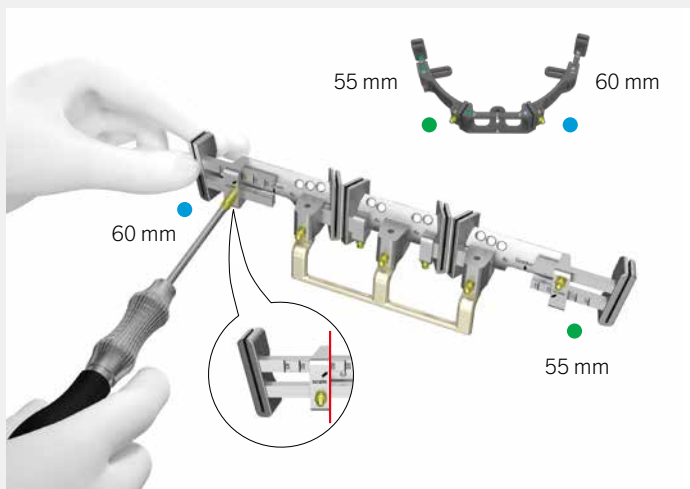

#### 4. Preparation of the guide – setting the resection value

The two outer saw guides can be set within the defined length range (45-65 mm or 65-80 mm, depending on the selection of the short or long guide) in increments of one millimeter.

For this purpose the gold-colored hexagon screw is loosened with the appropriate screwdriver blade so the saw guide can move freely to and fro and can be set to the required value.

The inner edge of the lateral segment represents the read-off edge and is marked with the word "Scale" and an arrow.

For fixation of the final position the gold-colored hexagon screw is retightened.

*Note:*

*The resection value set on the mandible must be accurately transferred to the fibular guide.*

#### 5. Alignment of the guide

The fibular resection guide can be used for both the right leg and the left leg.

The guide is placed on the fibula in such a way that the fixation bar is facing toward caudal. An additional mark, consisting of the word "Septum" and an arrow pointing down, illustrates the direction of placement.

Depending on requirements, the guide can be applied in such a way that the perforator relative to the skin is exactly at the center of one of the segments, or as distal as possible in order to generate a longer vascular pedicle. In this step a minimum distance of 6 cm from the lateral malleolus should be maintained in order to avoid compromising the stability of the ankle joint.



Screwdriver handle, flat



Hexagon blade, for tightening guide fixation screws

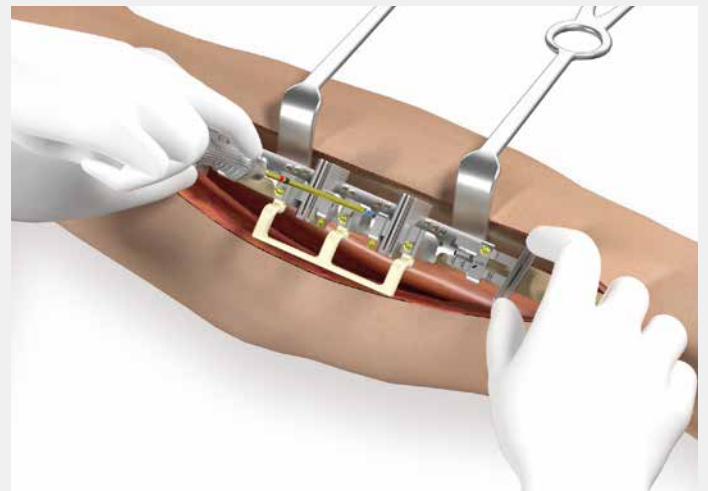
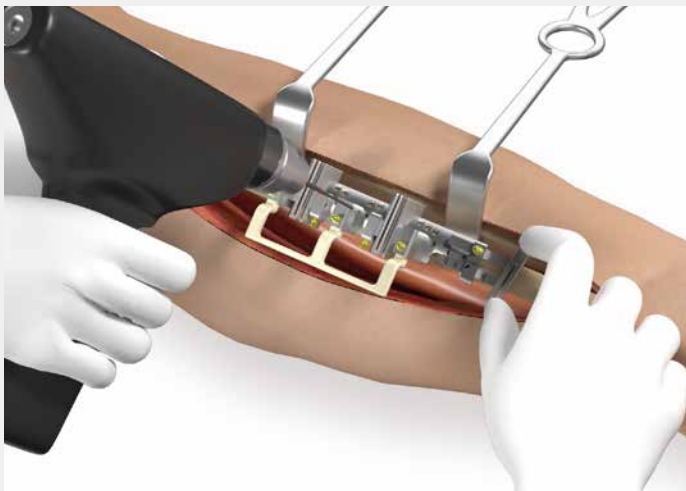

### 6. Temporary fixation of the guide to the fibula

The guide is temporarily fixated to the fibula with 2.0 mm dia. standard screws. For this purpose there are six holes available; two in each of the lateral segments and two in the center segment.

For fixation the respective core hole is first drilled with the corresponding drill bit. The 2.0 mm dia. standard screw is picked up and driven in with the black screwdriver for the aseptic area.

More screws are placed according to the described technique. Maximum hole filling is recommended.

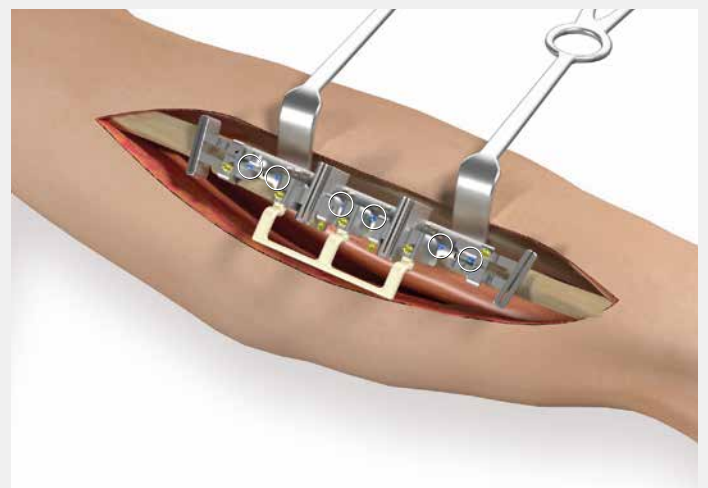

Drill bit for  
2.0 mm  
dia. screws



Screwdriver  
handle, flat



maxDrive®  
blade,  
dia. 2.0 mm

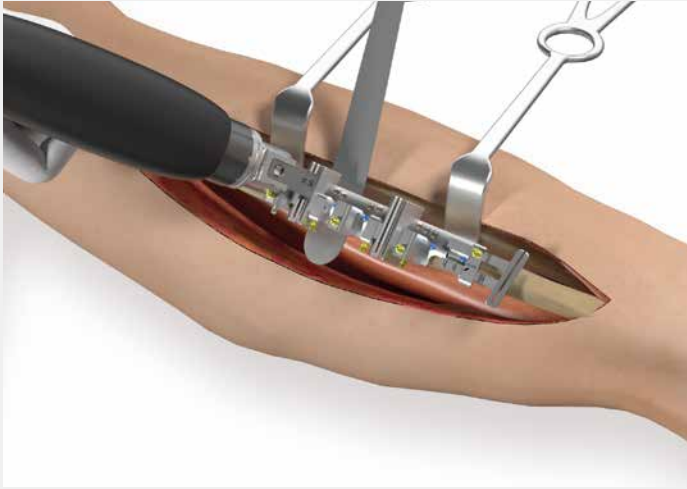

### 7. Performing the resection (osteotomies)

After adequate fixation the fixation bar can be removed from the guide.

The resection guide enables targeted incision within the saw guides.

For defined osteotomy the saw blade must have the following characteristics and dimensions:

Sagittal saw blade

Cutting thickness: 0.6 mm

Width of working blade: 15 mm

Length: 27-40 mm

*Note:*

*To be able to achieve the best possible results it is always necessary to use not only a powerful motor system but also a new saw blade.*

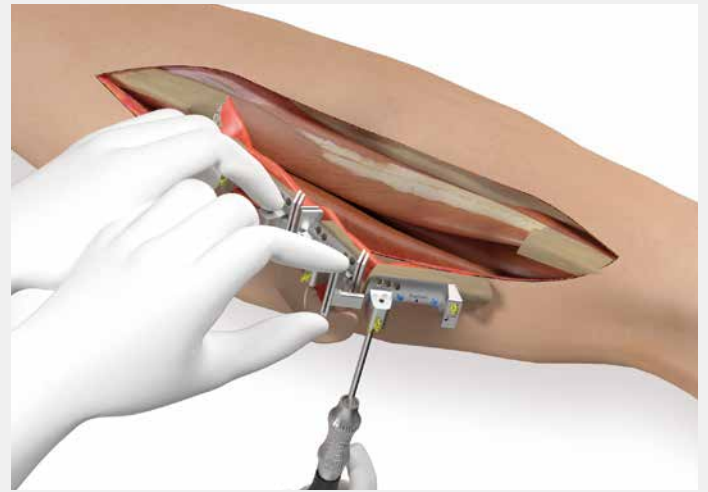
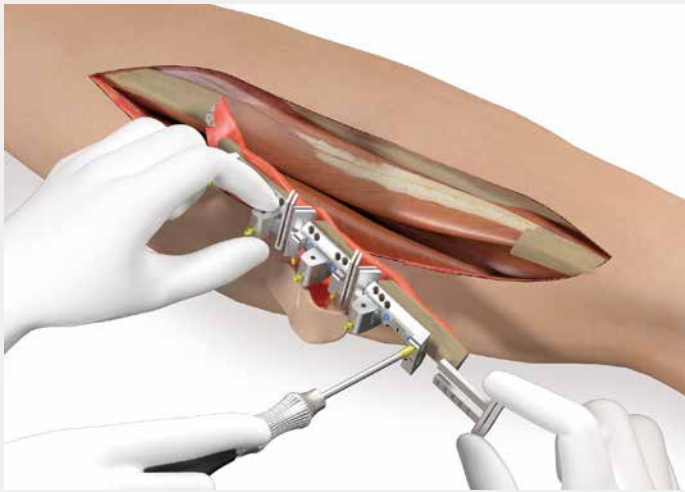

### 8. Removal of all saw guides after resection

When all the osteotomies have been performed on the fibula, the saw guides are removed from the resection guide so that only the three main segments remain with the bone parts attached.



Screwdriver handle, flat

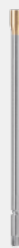

Hexagon blade, for tightening guide fixation screws



### 9. Transfer to the angled graft bar

Using the angled bar the bone segments can be placed in the required angular position and held in that position.

For this purpose the center segment with the attached bone is first placed on the center branch of the bar and then the two lateral segments are placed on the lateral branches.

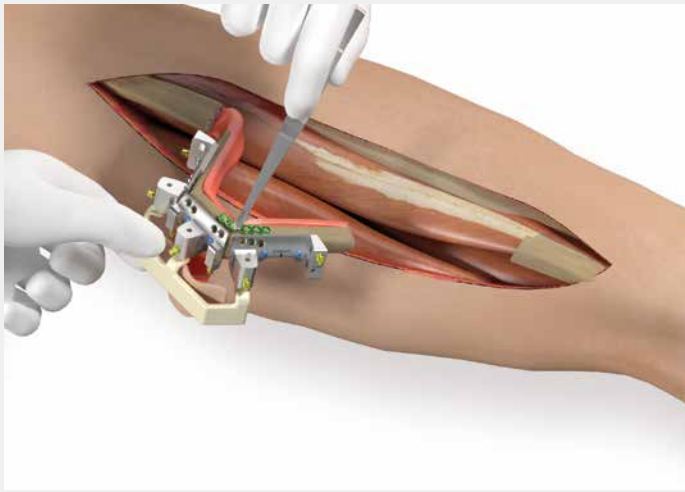

**10. Fixation of the graft from anterior – introduction of the first special plate**

The recesses integrated into the fibular resection guide enable fixation of the graft while the guide is in place because the specially designed plates (25-755-00-91/71 and 25-755-01-91/71), which are contoured according to the angulation of the graft, are introduced from above and fixated from anterior.

The plates are color-coded according to the color of the guide so they can be assigned to a specific side.

The first plate is picked up with forceps and introduced to the recess from above.

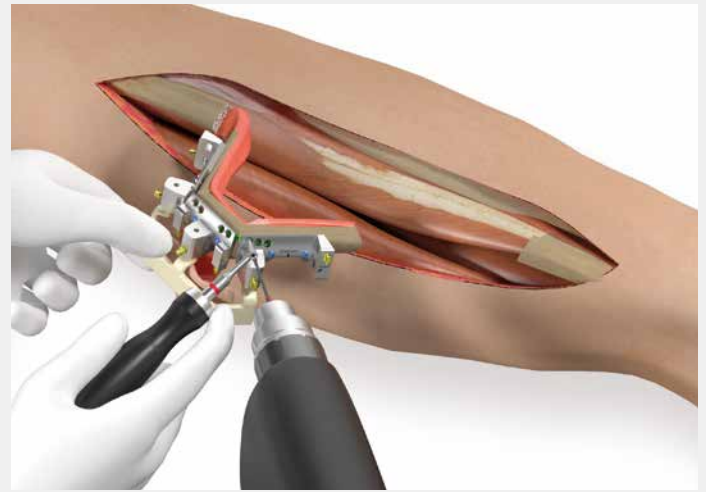

**11. Fixation of the graft from anterior – drilling with the drill guide**

When the plate has been inserted in the recess from above, it can, if necessary, also be aligned and held in position with the aid of the drill guide.

For plate fixation the respective core hole is first drilled with the corresponding drill bit using the drill guide.



Plate holding forceps



Symphysis plate



Drill guide, 2.0 mm



Drill bit for 2.0 mm dia. screws

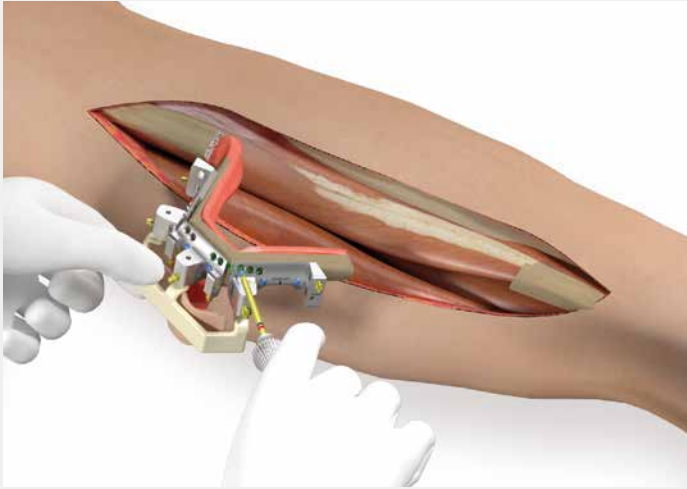

**12. Fixation of the graft from anterior – placement of the screws**

The 2.0 mm dia. standard screw is picked up and driven in with the color-coded screwdriver.

More screws are then placed according to the described technique.

**13. Fixation of the graft from anterior – introduction and fixation of the second special plate**

The second plate is introduced to the recess from above with forceps and fixated according to the technique described in steps 11 to 12.



Screwdriver handle, flat



maxDrive® blade, dia. 2.0 mm



Plate holding forceps



Symphysis plate



Drill guide, 2.0 mm



Drill bit for 2.0 mm dia. screws



Screwdriver handle, flat



maxDrive® blade, dia. 2.0 mm



#### 14. Removal of the guide

When the graft has been primarily fixated using the anterior two plates, the remaining guide segments can be removed by loosening the 2.0 mm dia. standard screws.



Screwdriver  
handle, flat



maxDrive®  
blade,  
dia. 2.0 mm

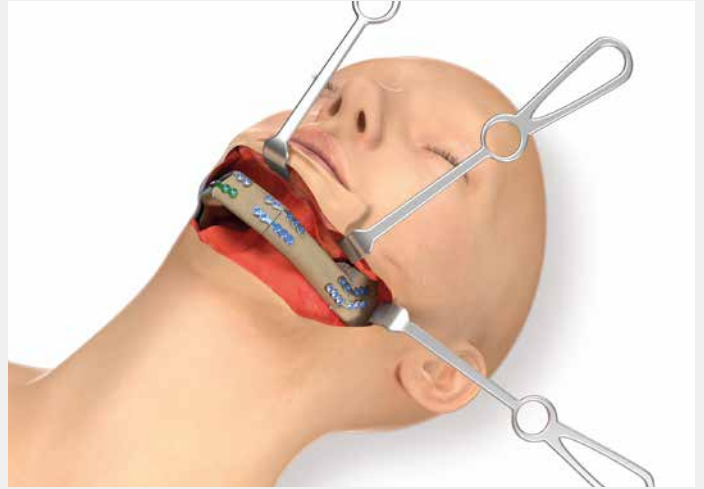

**15. Introduction of more plates**

To achieve adequate stability more plates are attached in the anterior graft region.

By way of example, treatment in this case is performed using a 6-hole symphysis plate and a 5-hole symphysis plate. However, the osteosynthesis plate is always selected according to the individual anatomical situation.

**16. Placement of the graft in the mandible and fixation**

When the vascular pedicle has been transected, the graft is placed in the mandible and fixated.

For this step the instruments and implants used on the fibula are taken upward from the lower leg to the mandible.





#### **Follow-Up Treatment**

The x-ray image shows postoperative findings. After a consolidation phase of 6 months, metal removal and the placement of 4 implants for dental rehabilitation are planned.

## Instruments **L1**® Mandible ReconGuide Resection Guides



25-500-00-07  
Mandibular resection guide,  
complete

St PEEK 1



Explanation of icons

- St** Steel
- PEEK** PEEK
- 1** Units per package

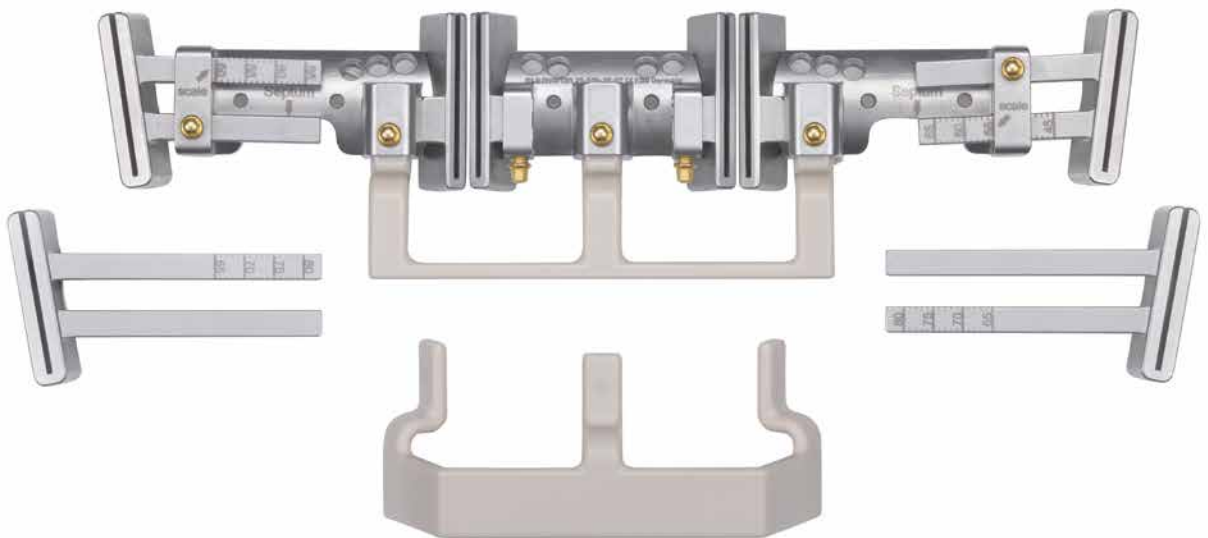

25-500-20-07  
Fibular resection guide,  
complete

**St** **PEEK** **1**

## Instruments L1® Mandible ReconGuide Standard Instrumentation

Instruments for use on the fibula and for graft fixation

- for assembly of the fibular resection guide
- for temporary attachment of the fibular resection guide to the fibula
- for osteosynthesis of the fibular graft and for fixation in the mandible



1/2

25-407-04-04  
Screwdriver handle,  
flat, rotatable



1/2

25-500-35-07  
Hexagon blade,  
for tightening  
guide fixation screws



1/2

25-486-97-07  
maxDrive® blade,  
dia. 2.0 mm



1/2

25-650-10-04  
Screw measurement  
clip, length and  
diameter



1/2

25-500-40-07  
Drill guide,  
2.0 mm



1/2

25-461-07-91  
25-461-07-71  
Drill bit for 2.0 mm dia. screws,  
dia. 1.5 x 55 mm, stop 7 mm  
coordinated with drill guide





Explanation of icons

- Steel
- Silicone
- maxDrive®
- System diameter 2.0 mm
- J-coupling
- Units per package

**STERILE IR** Sterile packaged instruments

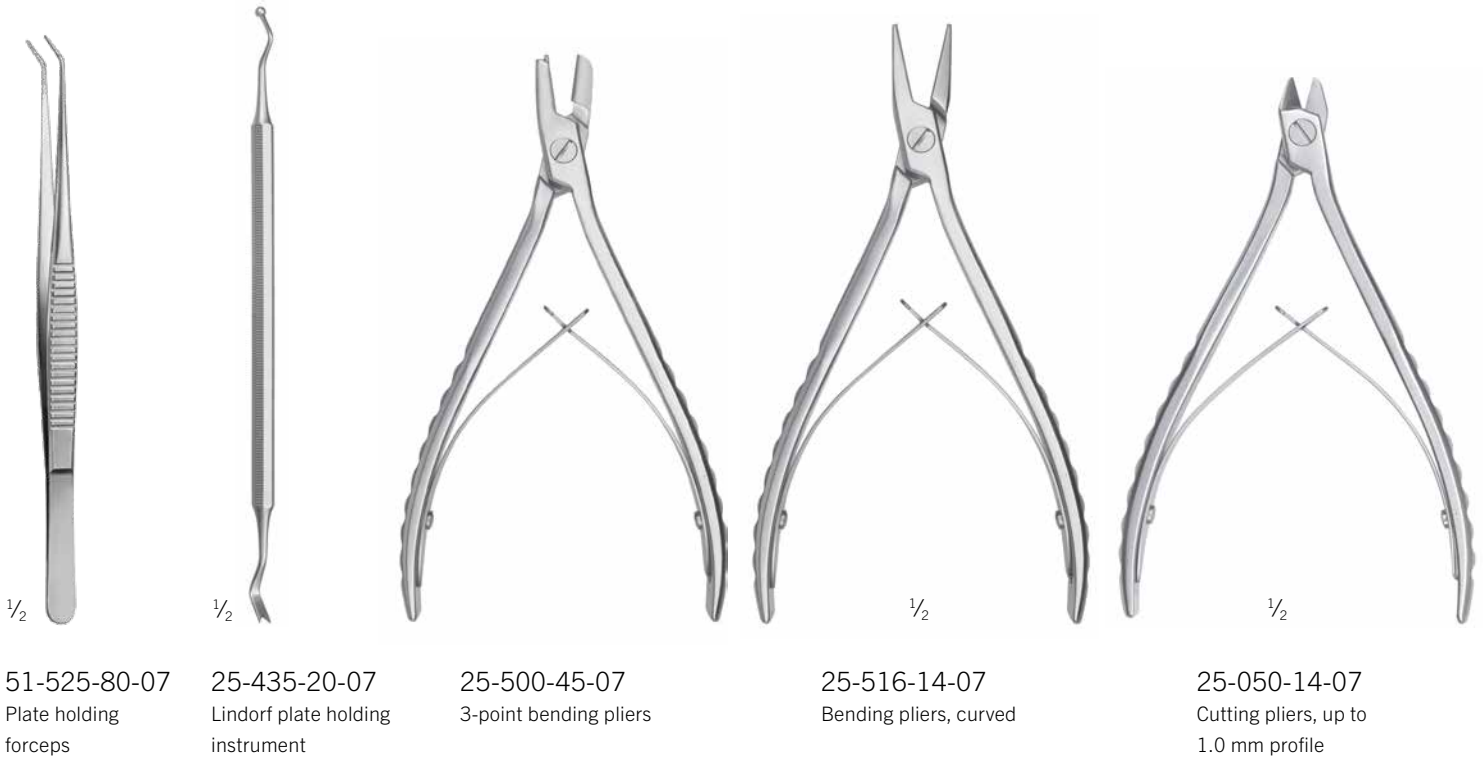

1/2

51-525-80-07  
Plate holding  
forceps

1/2

25-435-20-07  
Lindorf plate holding  
instrument

1/2

25-500-45-07  
3-point bending pliers

25-516-14-07  
Bending pliers, curved

1/2

25-050-14-07  
Cutting pliers, up to  
1.0 mm profile

St 1

St 1

St 1

St 1

St 1

## Instruments **L1**® Mandible ReconGuide Standard Instrumentation

Instruments for use on the mandible (septic)

- for assembly of the mandibular resection guide
- for temporary attachment of the mandibular resection guide to the mandible



1/2

25-407-10-04  
Screwdriver handle,  
red, flat, rotatable



1/2

25-500-35-07  
Hexagon blade,  
for tightening  
guide fixation screws



1/2

25-486-97-07  
maxDrive® blade,  
dia. 2.0 mm



1/2

25-461-16-91  
25-461-16-71  
Drill bit for 2.0 mm dia. screws,  
dia. 1.5 x 70 mm  
No stop





Explanation of icons

- St Steel
- Sic Silicone
- maxDrive®
- System diameter 2.0 mm
- J-coupling
- Units per package

**STERILE IR** Sterile packaged instruments

## Implants **L1**® Mandible ReconGuide 2.0-mm Miniplates in profile thickness 1.0 mm

Primary fixation of the graft in the symphysis region

**Symphysis plates, coordinated with the recesses integrated into the fibular guide**

5-hole, blue

5-hole, green



25-755-00-91 Ti 1

25-755-01-91 Ti 1

25-755-00-71 Ti 1

25-755-01-71 Ti 1

= 1.0 mm

= 1.0 mm

**Symphysis plate**

4-hole

**Symphysis plate**

5-hole

**Symphysis plate**

6-hole



25-755-05-91 Ti 1

25-755-06-91 Ti 1

25-755-07-91 Ti 1

25-755-05-71 Ti 1

25-755-06-71 Ti 1

25-755-07-71 Ti 1

= 1.0 mm

= 1.0 mm

= 1.0 mm



Explanation of icons

- Pure titanium
- Units per package
- Plate profile

**STERILE IR** Sterile packaged implants

### Fixation of the graft in the mandible

**Straight plate**  
4-hole



25-755-02-91

25-755-02-71

= 1.0 mm

**Straight plate**  
5-hole



25-755-03-91

25-755-03-71

= 1.0 mm

**Straight plate**  
6-hole



25-755-04-91

25-755-04-71

= 1.0 mm

**Angled plate**  
4-hole



25-755-08-91

25-755-08-71

= 1.0 mm

**Angled plate**  
3+2-hole



25-755-09-91

25-755-09-71

= 1.0 mm

**Angled plate**  
2+3-hole



25-755-10-91

25-755-10-71

= 1.0 mm

**Angled plate**  
6-hole



25-755-11-91

25-755-11-71

= 1.0 mm

# Implants L1® Mandible ReconGuide maxDrive® Screws

maxDrive® 

## Standard screws Self-retaining



| dia. x Length | Non-sterile  | STERILE   R  |
|---------------|--------------|--------------|
| 2.0 x 4 mm    | 25-872-04-61 | 25-872-04-71 |
| 2.0 x 5 mm    | 25-872-05-61 | 25-872-05-71 |
| 2.0 x 6 mm    | 25-872-06-61 | 25-872-06-71 |
| 2.0 x 7 mm    | 25-872-07-61 | 25-872-07-71 |
| 2.0 x 9 mm    | 25-872-09-61 | 25-872-09-71 |
| 2.0 x 11 mm   | 25-872-11-61 | 25-872-11-71 |
| 2.0 x 13 mm   | 25-872-13-61 | 25-872-13-71 |
| 2.0 x 15 mm   | 25-872-15-61 | 25-872-15-71 |
| 2.0 x 17 mm   | 25-872-17-61 | 25-872-17-71 |
| 2.0 x 19 mm   | 25-872-19-61 | 25-872-19-71 |

## Emergency screws Self-retaining



| dia. x Length | Non-sterile  | STERILE   R  |
|---------------|--------------|--------------|
| 2.3 x 4 mm    | 25-873-44-61 | 25-873-44-71 |
| 2.3 x 5 mm    | 25-873-45-61 | 25-873-45-71 |
| 2.3 x 7 mm    | 25-873-47-61 | 25-873-47-71 |
| 2.3 x 9 mm    | 25-873-49-61 | 25-873-49-71 |

## Drill free screws (optional) Self-retaining, self-tapping



| dia. x Length | Non-sterile  | STERILE   R  |
|---------------|--------------|--------------|
| 2.0 x 5 mm    | 25-879-05-61 | 25-879-05-71 |
| 2.0 x 6 mm    | 25-879-06-61 | 25-879-06-71 |
| 2.0 x 7 mm    | 25-879-07-61 | 25-879-07-71 |
| 2.0 x 9 mm    | 25-879-09-61 | 25-879-09-71 |



Explanation of icons

- Titanium alloy
- Steel
- maxDrive®
- J-coupling
- System diameter 2.0 mm
- Units per package

**STERILE IR** Sterile packaged implants

Drill bits

- 

for 2.0 mm dia. screws

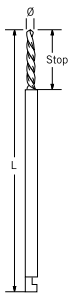

| dia. x Length                                     | Stop    | Non-sterile  | <b>STERILE IR</b> |
|---|---------|--------------|-------------------|
| 1.5 x 50 mm                                       | 5 mm    | 25-449-05-91 | 25-449-05-71      |
| 1.5 x 50 mm                                       | 7 mm    | 25-449-07-91 | 25-449-07-71      |
| 1.5 x 50 mm                                       | 9 mm    | 25-449-09-91 | 25-449-09-71      |
| 1.5 x 50 mm                                       | 11 mm   | 25-449-11-91 | 25-449-11-71      |
| 1.5 x 50 mm                                       | 21 mm   | 25-449-16-91 | 25-449-16-71      |
| Coordinated with drill guide 25-500-40-07:        |         |              |                   |
| 1.5 x 55 mm                                       | 7 mm    | 25-461-07-91 | 25-461-07-71      |
| For attachment of the mandibular resection guide: |         |              |                   |
| 1.5 x 70 mm                                       | no stop | 25-461-16-91 | 25-461-16-71      |



## Storage **L1**® Mandible ReconGuide for Instruments

The storage concept has been matched to the special requirements of mandibular reconstruction and considers the strict separation of the surgical zones "Mandible" and "Fibula".

The instrument insert intended for the septic area of the mandible is marked with a red labeling clip so it is easy to distinguish from other components destined for the fibula.

All the instruments can be stored individually next to each other.

In addition to easy, well-thought-out handling, the storage system is particularly impressive because of its optimized reprocessing capability, due to large openings of honeycomb design.

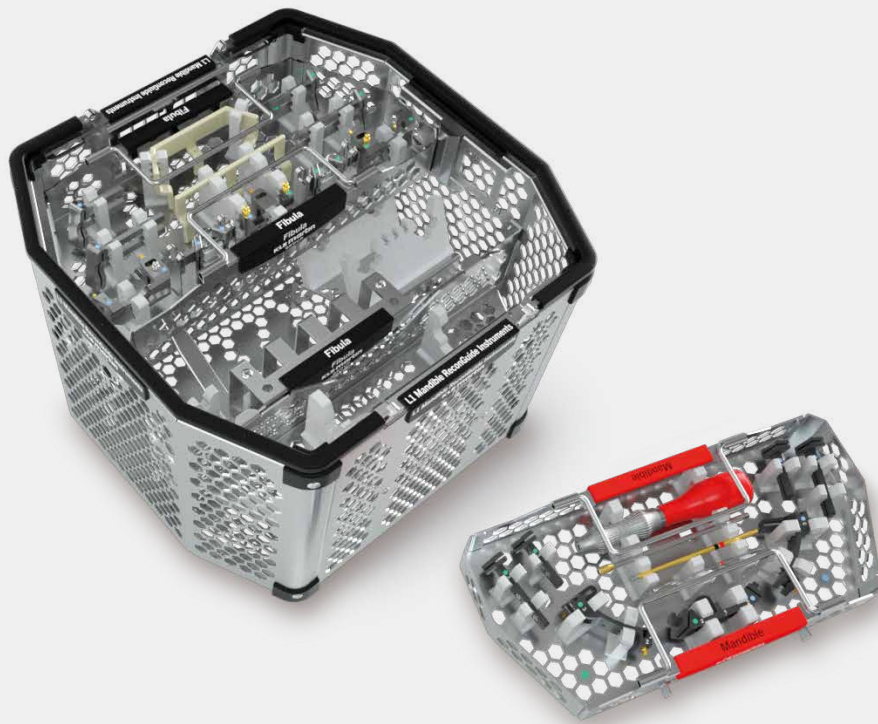

|                     |   |
|---------------------|---|
| <b>55-990-50-04</b> | <b>L1® Mandible ReconGuide instrument storage set, consisting of:</b> |
| 55-990-51-04        | Instrument basket   |
| 55-990-52-04        | Mandibular insert   |
| 55-990-53-04        | Fibular insert  |
| 55-910-59-04        | Lid   |



55-990-51-04  
Instrument basket

1



55-990-52-04  
Mandibular insert

1



55-990-53-04  
Fibular insert

1



55-910-59-04  
Lid

1

## Storage L1® Mandible ReconGuide for non-sterile packaged Implants

The **implant basket** is used to keep screw and plate modules.

For transparent organization and easy identification all the module fronts have color-coded labeling clips that clearly indicate the contents.

**Screw modules** allow direct, application-oriented access to the screws. After the operation the empty single clips can be taken out of the module from any position.

Due to labeling with article number, batch number, and GTIN number all the relevant implant data are provided on the single clip. The printed Data Matrix code also enables easy recording with a scanner system and further processing of data. That means all the conditions are fulfilled for ensuring transparent, patient-related and seamless documentation, as well as reordering.

In the **plate module** the plates are clearly arranged and kept separate from each other. Each plate compartment is marked at the side with a labeling clip that bears the article number, the profile, and a picture of the plate. As a result, the necessary information is provided for application-oriented access and intuitive refilling.

The matt inner surface of the module increases the contrast and allows enjoyable, dazzle-free work under the surgical light.



**55-990-55-04 L1® Mandible ReconGuide implant storage set, consisting of:**

|              |   |
|--------------|---|
| 55-990-56-04 | Implant basket, without modules   |
| 55-990-57-04 | Screw module 1/3, standard 2.0 mm dia. screws (MANDIBLE)                    |
| 55-990-58-04 | Screw module 2/3, standard and emergency 2.0 mm dia. screws (FIBULA)        |
| 55-990-59-04 | Plate module 2/3, configured for 2.0 miniplates in profile thickness 1.0 mm |



55-990-56-04  
Implant basket, without modules



55-990-59-04  
Plate module 2/3,  
for 2.0 miniplates



55-990-57-04  
Screw module 1/3,  
for standard  
2.0 mm dia. screws  
**(40 screw single clips)**

Configured for:  
Standard 2.0 mm dia. screws  
4 x 7 mm  
8 x 9 mm  
8 x 11 mm  
8 x 13 mm  
8 x 15 mm  
4 x 17 mm



55-990-58-04  
Screw module 2/3,  
for standard and emergency  
2.0 mm dia. screws  
**(100 screw single clips)**

Configured for:  
Standard 2.0 mm dia. screws  
20 x 5 mm  
20 x 6 mm  
20 x 7 mm  
10 x 9 mm  
10 x 11 mm  
Emergency screws  
10 x 5 mm  
10 x 7 mm

## CMF Surgery

### SonicWeld Rx®

Resorbable implants for use in craniomaxillofacial osteosynthesis

- Resorb x®
- Resorb xG

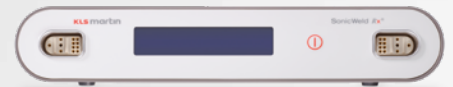

It is the face that makes humans unique and unmistakable – “There is nothing that more closely reflects the life of an individual than the human face\*.”

Our objective is to simplify craniofacial surgery with specially designed implant systems that ensure optimum satisfaction for both surgeon and patient. Together with renowned users we translate new ideas into innovative products and are constantly enhancing them.

Our range of products includes everything necessary for modern craniofacial surgery. We not only set standards but we also go beyond to take advantage of modern technology in the development of solutions customized for the individual patient.

KLS Martin – your competent and reliable partner for both everyday challenges and special challenges.

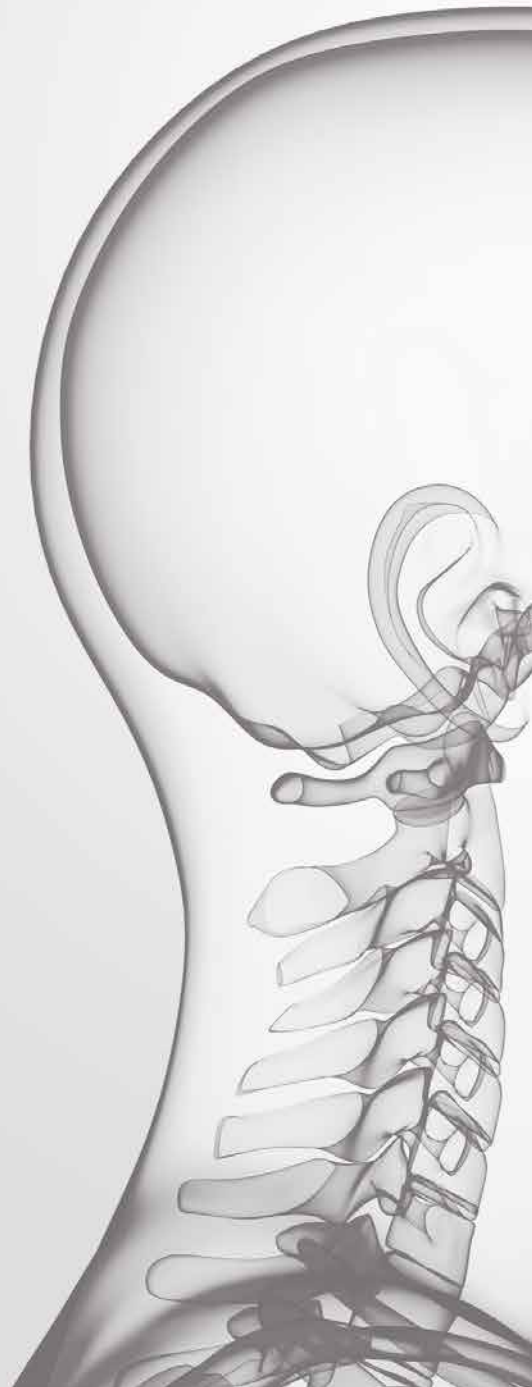

\* © Kurt Haberstich (\*1948)

## Distractors

Devices for use in correction of malformations

- Cranial distraction
- Midface distraction
- Mandibular distraction



## Individual Patient Solutions

Patient-specific solutions for use in craniomaxillofacial surgery

- IPS Implants®
- IPS CaseDesigner®
- IPS Gate®



## Level One Fixation

Titanium implants and instruments for use in craniomaxillofacial osteosynthesis

- Traumatology
- Reconstruction
- Orthognatic surgery



## App for CMF products

All important information about the CMF portfolio at one glance.

Available on the App Store iOS



GET IT ON Google play Android

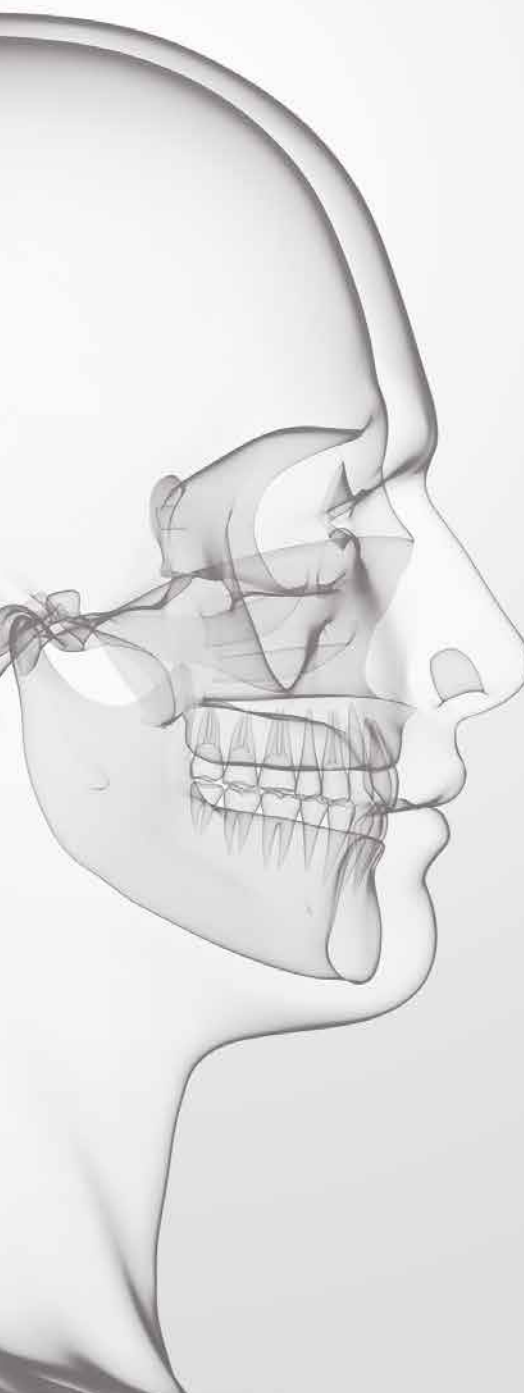

## KLS Martin Group

### **KLS Martin Australia Pty Ltd.**

Sydney · Australia  
Tel. +61 2 9439 5316  
australia@klsmartin.com

### **KLS Martin do Brasil Ltda.**

São Paulo · Brazil  
Tel. +55 11 3554 2299  
brazil@klsmartin.com

### **KLS Martin Medical (Shanghai) International Trading Co., Ltd.**

Shanghai · China  
Tel. +86 21 5820 6251  
china@klsmartin.com

### **KLS Martin India Pvt Ltd.**

Chennai · India  
Tel. +91 44 66 442 300  
india@klsmartin.com

### **Martin Italia S.r.l.**

Milan · Italy  
Tel. +39 039 605 67 31  
italia@klsmartin.com

### **Nippon Martin K.K.**

Tokyo · Japan  
Tel. +81 3 3814 1431  
nippon@klsmartin.com

### **KLS Martin SE Asia Sdn. Bhd.**

Penang · Malaysia  
Tel. +604 505 7838  
malaysia@klsmartin.com

### **Martin Nederland/Marned B.V.**

Huizen · The Netherlands  
Tel. +31 35 523 45 38  
nederland@klsmartin.com

### **Gebrüder Martin GmbH & Co. KG**

Moscow · Russia  
Tel. +7 499 792-76-19  
russia@klsmartin.com

### **Gebrüder Martin GmbH & Co. KG**

Dubai · United Arab Emirates  
Tel. +971 4 454 16 55  
middleeast@klsmartin.com

### **KLS Martin UK Ltd.**

London · United Kingdom  
Tel. +44 1189 000 570  
uk@klsmartin.com

### **KLS Martin LP**

Jacksonville · Florida, USA  
Tel. +1 904 641 77 46  
usa@klsmartin.com

### **Gebrüder Martin GmbH & Co. KG**

#### **A company of the KLS Martin Group**

KLS Martin Platz 1 · 78532 Tuttlingen · Germany  
P.O. Box 60 · 78501 Tuttlingen · Germany  
Tel. +49 7461 706-0 · Fax +49 7461 706-193  
info@klsmartin.com · www.klsmartin.com

